

CamCon Display

CD10



Digitronic Automationsanlagen GmbH

Steinbeisstraße 3 · D - 72636 Frickenhausen · Tel. (+49)7022/40590-0 · Fax -10
Auf der Langwies 1 · D - 65510 Hünstetten-Wallbach · Tel. (+49)6126/9453-0 · Fax -42
Internet: <http://www.digitronic.com> · E-Mail: mail@digitronic.com

Notification

This booklet corresponds with the state of the CamCon CD10 from 2.4.1997. The company Digitronic Automationsanlagen GmbH has reserved all rights to alterations without prior notice, if these are followed by an improvement of the quality or the functioning of this piece of equipment.

The instruction booklet has been constructed exercising maximum care, but mistakes are not exactly out of the question. We are grateful for any hints concerning possible mistakes in the booklet.

Qualified personal only

Commissioning and operation of the device may only be carried out by qualified personal. Qualified personal are persons, authorized with commissioning, grounding and labeling devices, systems and electrical circuits according to the applicable standards of security

LIABILITY

(1) The salesperson is liable for any damages for which he or the rightful owner is responsible up to the amount of the actual salesprice. Liability concerning missed profits, failed-to-appear savings, indirect damages and consequential damage is excluded.

(2) The liability restrictions above are not valid concerning assured characteristics and damages, which are caused by intention or coarse negligence.

PROTECTION

CamCon CD10 and this booklet are protected by copyright. All rights are reserved. Neither CamCon CD10 nor this document may be partly or wholly copied, photocopied, reproduced, translated or transfered onto any electrical media or forms which are readable by machine without prior, written permit through the company Digitronic Automationsanlagen GmbH.

Note: The products of Digitronic are so well constructed that they will not be effected by the millenium.

Note: CamCon is a registered trademark of the company Firma Digitronic Automationsanlagen GmbH.

Note: The cam controllers of the CamCon series fullfill the norms regarding electromagnetic emission: EN 55011, EN 55022, EN 55024 Part 2, EN 50082 Part 2, ENV 50140, VDE 0843 Part 2, VDE 0843 Part 4, VDE 0871, VDE 0875 Part 3 ("N"), VDE 0875 Part 11, VDE 0877 Part 2, IEC 801 Part 3, IEC 801 Part 2, IEC 801 Part 4, IEC 801 Part 5.



(c) Copyright 1992 - 2002 / File: CD10E.DOC

Digitronic Automationsanlagen GmbH
Auf der Langwies 1
D-65510 Hünstetten - Wallbach
Tel. (+49)6126/9453-0 Fax. (+49)6126/9453-42
Internet: <http://www.digitronic.com>
E-Mail: mail@digitronic.com

Content

1. Introduction	3
2. Installation.....	4
2.1. Dimensions.....	4
2.2. Dimensions of the switch gear sector according to DIN 43700.....	4
3. Clamp allocation	4
3.1. Clamp allocation of the voltage supply	4
3.2. Clamp allocation of the inputs.....	4
3.3. Pin allocation of the serial RS485 interface	5
4. Adjustment of the DIP switch.....	6
4.1. Adjustment of the own device number via the DIP switches 1 to 4.....	6
4.2. Adjustment of the mode of communication via the DIP switch 5	6
4.3. Adjustment of the DIP switch 6	6
5. Inputs	6
5.1. Inputs 1 - 4.....	6
5.2. Inputs 5 + 6.....	7
6. Modes of display	7
6.1. Mode of display "Automatic"	7
6.2. Display "Speed" or "Position"	7
7. Technical data.....	8
8. List of key words	8

1. Introduction

The CamCon CD10 Display is a four-digit subsidiary display for cam switch mechanisms of the CamCon series. As a standard, the position, the speed or a fault message of a CamCon cam switch mechanism could be displayed. The data transfer is performed by the RS485 interface of the CamCon cam switch mechanism.

Note: In order to communicate with the CamCon CD10 display, the serial interface of the CamCon cam switch mechanism shall be adjusted to "**Multiuser**" or "**Cam-Bus**". If there are several CamCon CD10 Displays operated in one RS485 – BUS or if there is a personal computer or CamCon Terminal additionally connected all devices (the personal computer, too) shall be adjusted to "**Cam-Bus**". For this, see chapter "4.2. Adjustment of the mode of communication via the " at page 6.

2. Installation

The unit is inserted into a cutout for front plate installation (see chapter "2.1. Dimensions" on page 4). Connect the grounded pins on the back of the encasement as well as the cable cover to a grounding point of the switchboard door in the shortest possible way. All cable connections must be done in a cold state! The connection cables, e.g. for the measuring system or the serial interface, must be wired with covers, and the covers have to be grounded on both ends. Analog signals must also be wired with covers, and the covers have to be grounded on one end.

2.1. Dimensions

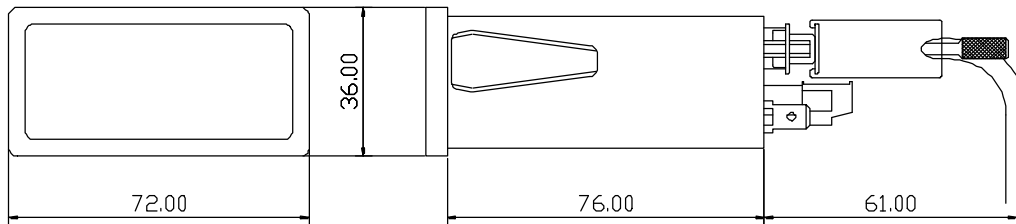

2.2. Dimensions of the switch gear sector according to DIN 43700

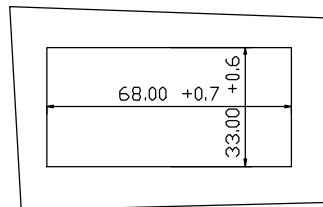

3. Clamp allocation

3.1. Clamp allocation of the voltage supply

Clamp	1:	0V voltage supply
Clamp	2:	0V voltage supply
Clamp	3:	+24V DC voltage supply
Clamp	4:	+24V DC voltage supply

3.2. Clamp allocation of the inputs

Clamp	5:	input 1
Clamp	6:	input 2
Clamp	7:	input 3
Clamp	8:	input 4
Clamp	9:	input 5
Clamp	10:	input 6

3.3. Pin allocation of the serial RS485 interface

As a standard, the CamCon CD10 Display has got a serial RS485 interface. This interface is connected to the RS485 interface of a CamCon DC16/40/50/90 or DC115 cam switch mechanism. The cable length of this RS485 interface is limited to 1,000 m at maximum.

Pin	1,4:	final resistors
Pin	2:	B (-)
Pin	3:	A (+)
Pin	5:	0V signal mass
Pin	6-9:	must not be allocated.

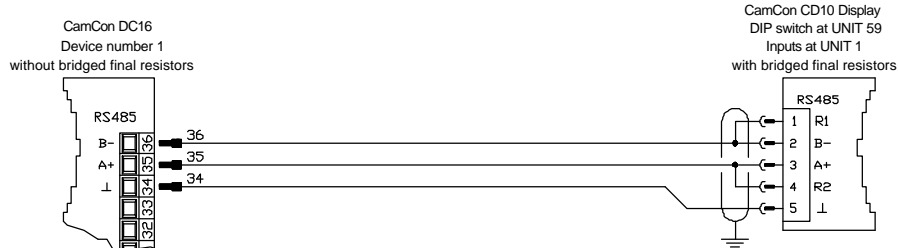

Please, note: At the RS485 interface, the ends of the data line shall be connected with final resistors. For this, resistors are designed at PIN 1 and 4 in the CamCon CD10 Display, which shall be connected before setting into operation. The final resistors must be bridged only at the beginning and at the end of a network chain, otherwise there would be an overload of the RS485 interface, and the communication would be disturbed.

Example: Switching on 2 CamCon DC16 and 2 CamCon CD10 Display by means of one personal computer.

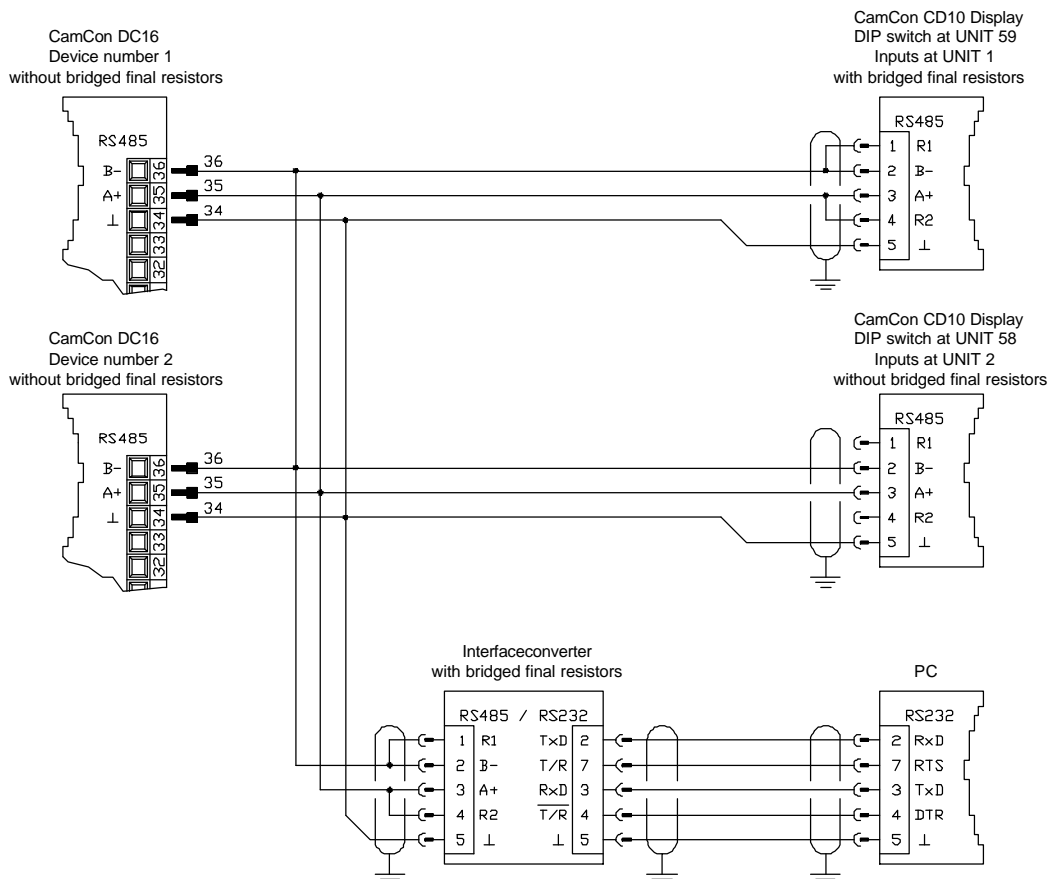

4. Adjustment of the DIP switch

4.1. Adjustment of the own device number via the DIP switches 1 to 4

By means of the DIP switches 1 - 4 at the backside of the device you can adjust the device number of the CamCon CD10 Display. This is necessary in order to clearly identify the device in a RS485 – BUS. The basic device number of the CamCon CD10 Display is the number 59. The four DIP switches are subtracted from this basic number as a binary code, the result of which is the own device number. If for instance, the DIP switches 1 + 3 are switched "ON", the number will be 54. This number shall be awarded only once in the entire RS485 – BUS.

4.2. Adjustment of the mode of communication via the DIP switch 5

If the DIP switch 5 is switched "ON" this would mean the mode of communication "**Multiuser**". Is the DIP switch "OFF", the mode of communication "**Cam-Bus**" is switched on.

Cam-Bus: You shall select this adjustment if you want to connect several CamCon CD10 Displays or other CamCon devices by means of the RS485 BUS. (e. g. a programming device of the type: DC51/T4, CamCon CD10 Display and PC).

Please, note: For this adjustment **all** CamCon devices as well as the personal computer shall be equipped with an RS485 interface and a software not older than of December 1996.

Multiuser: In contrast to the "Cam-Bus" mode, it is **not** possible to operate several CamCon CD10 Displays or an additional personal computer in the RS485 BUS.

4.3. Adjustment of the DIP switch 6

This DIP switch shall be always adjusted to "OFF" for a CamCon CD10 Display.

5. Inputs

The inputs of the CamCon CD10 Display are highly active and operate with 24-volt signals. The inputs are not free of potential for the voltage supply of the device.

Input wiring :

The input resistance is approx. 5.7 KOhm.

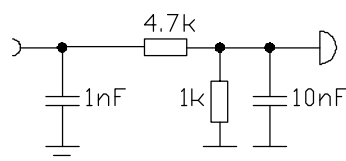

5.1. Inputs 1 - 4

The inputs 1 - 4 of the CamCon CD10 Display are used to adjust the number of that device with which a contact shall be established by means of a selector switch. For this, the first four inputs are binary encoded and used as device number. If for instance, 24 volt are applied at the inputs 1 + 3 the CamCon tries to establish a contact to the device number "5". Is the contact successfully established, the speed or the position of the CamCon cam switch mechanism are displayed. If there is no contact established the CamCon Display will indicate the number of the device with which communication failed. This is indicated by negative signs in front of and after the display. (e. g "-10-").

5.2. Inputs 5 + 6

The inputs 5 + 6 are used to configure the display of the CamCon CD10 Display. You could adjust 3 modes of display.

Input 5	Input 6	Mode of display
0	0	automatic
1	0	not permitted (CT10)
0	1	speed
1	1	position

6. Modes of display

6.1. Mode of display "Automatic"

Are the inputs 5 + 6 not active, the display automatically changes from position to speed as soon as the 5%- speed threshold value of the cam switch mechanism is exceeded (see the chapter "Adaptation of the range of the speed display" in the manual of the cam switch mechanism). In order to recognise which display is the active one at the moment, an additional LED (upper left) is switched on in the display during the display of position.

Note: This option does only work with a software of the cam switch mechanism that is not older than of December 1996. In the case that you use an older software, the CamCon Display will show the fault message "Err 9".

6.2. Display "Speed" or "Position"

If "Speed" is adjusted the display will show the present speed of the cam switch mechanism, if "Position" is adjusted the present position of the cam switch mechanism will be shown. In order to recognise which display is activated at the moment, an additional LED (upper left) is switched on in the display during the display of position.

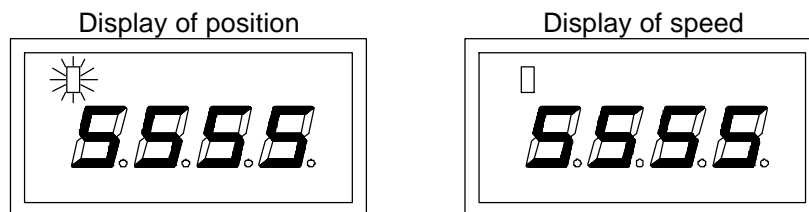

7. Technical data

Display.....	4-digit 7 seg. display + LED for the display of position and speed.
Inputs.....	6 x 24V high active approx. 5KOhm.
Number of the CamCon displayed	via the inputs 1 - 4 binary encoded.
Change-over Position/Speed	via inputs 5 + 6.
Interface	RS485 upto max. 1000m.
Supply voltage	24V DC \pm 20 %
Current consumption.....	50mA.
Connections for:	
interface	via D-SuB 9
Voltage supply.....	via screw terminals
Dimension.....	See chapter "2.1. Dimensions" at page 4.
Operating temperature	0°C ... + 55° C
Switch-board housing according to DIN 43700..	72 x 36 x 82.5mm (width x height x depth)
Weight	approx. 150g

8. List of key words

Cable covers	4
Cam-Bus.....	6
Clamp allocation.....	4
Content.....	3
Device number, own	6
Device number, shown.....	6
Dimensions	4
DIP switch	6
Display, position	7
Display, speed.....	7
Fault message	7
Grounding pins	4
Inputs.....	6
Inputs 1 - 4.....	6
Inputs 5 + 6.....	7
Installation	4
Installation procedures.....	4
millenium.....	2
Mode of communication	6
Mode of display, automatic	7
Modes of display.....	7
Multiuser	6
Technical data	8
Y2K	2