

ILA2T Modbus TCP

Lexium Integrated Drive

Product manual

V2.00, 11.2008



019844113652, V2.00, 11.2008

BERGER LAHR

www.schneider-electric.com

Schneider
Electric

HVS
PRECONISATEUR DE SOLUTIONS DEPUIS 1986

2 rue René Laennec 51500 Taissy France
Fax: 03 26 85 19 08, Tel : 03 26 82 49 29

E-mail: hvssystem@hvssystem.com
Site web : www.hvssystem.com

Important information

This manual is part of the product.

Carefully read this manual and observe all instructions.

Keep this manual for future reference.

Hand this manual and all other pertinent product documentation over to all users of the product.

Carefully read and observe all safety instructions and the chapter "Before you begin - safety information".

Some products are not available in all countries.

For information on the availability of products, please consult the catalog.

Subject to technical modifications without notice.

All details provided are technical data which do not constitute warranted qualities.

Most of the product designations are registered trademarks of their respective owners, even if this is not explicitly indicated.

Table of Contents

Important information	2
Table of Contents	3
Writing conventions and symbols	9
1 Introduction	11
1.1 About this manual	11
1.2 Unit overview	11
1.3 Components and interfaces	12
1.3.1 Components	13
1.3.2 Interfaces	13
1.4 Nameplate	14
1.5 Type code	15
1.6 Documentation and literature references	16
1.7 Declaration of conformity	17
1.8 TÜV certificate for functional safety	18
2 Before you begin - safety information	19
2.1 Qualification of personnel	19
2.2 Intended use	19
2.3 Hazard categories	20
2.4 Basic information	21
2.5 Functional safety	23
2.6 Standards and terminology	24
3 Technical Data	25
3.1 Certifications	25
3.2 Ambient conditions	25
3.3 Mechanical data	27
3.3.1 Degree of protection	27
3.3.2 Mounting position	28
3.3.3 Dimensions	28
3.4 Electrical Data	29
3.4.1 Supply voltage VDC at CN1	29
3.4.2 Fieldbus at CN2	29
3.4.3 Commissioning at CN3	30
3.4.4 24V signals at CN4	30
3.4.5 STO safety function at CN5 and CN6	31
3.5 Conditions for UL 508C	32

4	Basics	33
4.1	Functional safety	33
4.2	Modbus TCP technology	35
4.2.1	Function principle	35
4.2.2	Bus topology	35
4.2.3	Device model	35
4.2.4	Modbus TCP protocol	36
4.2.5	Generation of a Modbus response	37
4.2.6	MBAP header	38
4.2.7	Modbus port	39
4.2.8	Connection management	39
4.2.9	Implemented function codes	40
4.2.10	Reading and writing parameters	40
4.2.11	Examples of function codes FC	41
4.2.12	I/O Scanning	42
4.2.13	Faulty Device Replacement (FDR)	43
4.2.14	Network services	44
5	Engineering	45
5.1	Configurable inputs and outputs	45
5.2	External power supply units	45
5.2.1	Supply voltage	45
5.3	Ground design	47
5.4	Safety function STO ("Safe Torque Off")	48
5.4.1	Definitions	48
5.4.2	Function	48
5.4.3	Requirements for using the safety function	49
5.4.4	Application examples STO	51
5.5	Monitoring functions	52
6	Installation	53
6.1	Electromagnetic compatibility, EMC	54
6.2	Mechanical installation	56
6.3	Electrical installation	58
6.3.1	Wiring examples	59
6.3.2	Overview of all connections	60
6.3.3	Connection via cable entry	61
6.3.4	Connection with industrial connectors	64
6.3.5	Connection of VDC supply voltage	65
6.3.6	Connection to Ethernet fieldbus interface	68
6.3.7	RS485 interface connection	70
6.3.8	24V signal interface connection	71
6.3.9	Connection of STO safety function	73
6.4	Connection accessories	75
6.4.1	Accessory "Insert kit, 3x I/O"	75
6.4.2	Accessory "Insert kit, 2x I/O, 1x STO in"	75

6.4.3	Accessory "Insert kit, 1x STO in, 1x STO out"	75
6.4.4	Accessory "Insert kit, 4x I/O, 1x STO in, 1x STO out"	76
6.5	Checking wiring	76
7	Commissioning	77
7.1	Overview	80
7.2	Commissioning procedure	81
7.2.1	Possibilities of setting the IP address	81
7.2.2	Setting the IP address	82
7.2.3	Adding the device to the fieldbus	85
7.2.4	Lexium CT commissioning software	86
7.2.5	Web server	88
7.2.6	Connection monitoring	91
7.2.7	Setting basic parameters and limit values	93
7.2.8	Digital inputs / outputs	96
7.2.9	Checking the signals of the limit switches	97
7.2.10	Testing safety function STO	98
7.2.11	Releasing the holding brake manually	99
7.2.12	Checking direction of rotation	100
7.2.13	Setting parameters for encoder	101
7.3	Controller optimization with step response	104
7.3.1	Controller structure	104
7.3.2	Optimization	105
7.3.3	Optimizing the speed controller	106
7.3.4	Checking and optimizing default settings	110
7.3.5	Optimizing the position controller	111
8	Operation	113
8.1	Overview of operating modes	114
8.2	Access control	115
8.2.1	Via Ethernet fieldbus	115
8.2.2	Via commissioning software	116
8.2.3	Via signal inputs	116
8.3	Operating states	117
8.3.1	State diagram	117
8.3.2	Indicating the operating states	120
8.3.3	Changing operating states	123
8.4	Starting and changing operating modes	125
8.4.1	Starting an operating mode	125
8.4.2	Changing the operating mode	126
8.5	Operating modes	127
8.5.1	Operating mode Jog	127
8.5.2	Operating mode Speed control	131
8.5.3	Operating mode Profile position	132
8.5.4	Operating mode Profile velocity	136
8.5.5	Operating mode Homing	138

8.6	Functions	152
8.6.1	Monitoring functions	152
8.6.2	Scaling	160
8.6.3	Motion profile	163
8.6.4	Quick Stop	166
8.6.5	Halt	168
8.6.6	Fast position capture	170
8.6.7	Standstill window	172
8.6.8	Brake function	173
8.6.9	Configurable inputs and outputs	175
8.6.10	Reversal of direction of rotation	179
8.6.11	Restoring default values	181
8.6.12	I/O Scanning	182
9	Examples	189
9.1	Wiring examples	189
9.2	Wiring of the "STO safety function"	190
9.3	Sample settings	190
10	Diagnostics and troubleshooting	191
10.1	Service	191
10.2	Error indication	191
10.2.1	State diagram	192
10.2.2	LED signal codes	192
10.2.3	Error and status indication via LEDs	193
10.2.4	Diagnostics via Web server	193
10.2.5	Error indication using the commissioning software	193
10.2.6	Error indication via the fieldbus	194
10.3	Troubleshooting	196
10.3.1	Fieldbus communication	196
10.3.2	Troubleshooting of errors sorted by error bit	197
10.4	Table of error numbers	199
11	Parameters	207
11.1	Representation of the parameters	207
11.1.1	Explanation of the parameter representation	208
11.2	List of all parameters	210
12	Accessories and spare parts	237
12.1	Accessories	237
12.2	Gearboxes	238
13	Service, maintenance and disposal	239
13.1	Service address	240
13.2	Maintenance	240

13.2.1 Lifetime STO safety function 240

13.3 Replacing units 241

13.4 Shipping, storage, disposal 242

14 Glossary 243

14.1 Units and conversion tables 243

14.1.1 Length 243

14.1.2 Mass 243

14.1.3 Force 243

14.1.4 Power 243

14.1.5 Rotation 244

14.1.6 Torque 244

14.1.7 Moment of inertia 244

14.1.8 Temperature 244

14.1.9 Conductor cross section 244

14.2 Terms and Abbreviations 245

15 Index 249

019844113652, V2.00, 11.2008

Writing conventions and symbols

Work steps If work steps must be performed consecutively, this sequence of steps is represented as follows:

- Special prerequisites for the following work steps
- ▶ Step 1
- ◁ Specific response to this work step
- ▶ Step 2

If a response to a work step is indicated, this allows you to verify that the work step has been performed correctly.

Unless otherwise stated, the individual steps must be performed in the specified sequence.

Bulleted lists The items in bulleted lists are sorted alphanumerically or by priority. Bulleted lists are structured as follows:

- Item 1 of bulleted list
- Item 2 of bulleted list
 - Subitem for 2
 - Subitem for 2
- Item 3 of bulleted list

Making work easier Information on making work easier is highlighted by this symbol:



Sections highlighted this way provide supplementary information on making work easier.

Parameters In text sections, parameters are shown with the parameter name, for example `POSdirOfRotat`. The way parameters are represented in tables is explained in the chapter Parameters. The parameter list is sorted alphabetically by parameter name.

SI units SI units are the original values. Converted units are shown in brackets behind the original value; they may be rounded.

Example:

Minimum conductor cross section: 1.5 mm² (AWG 14)

1 Introduction

1.1 About this manual

This manual is valid for all ILA2T standard products. This chapter lists the type code for this product. The type code can be used to identify whether your product is a standard product or a customized model.

1.2 Unit overview

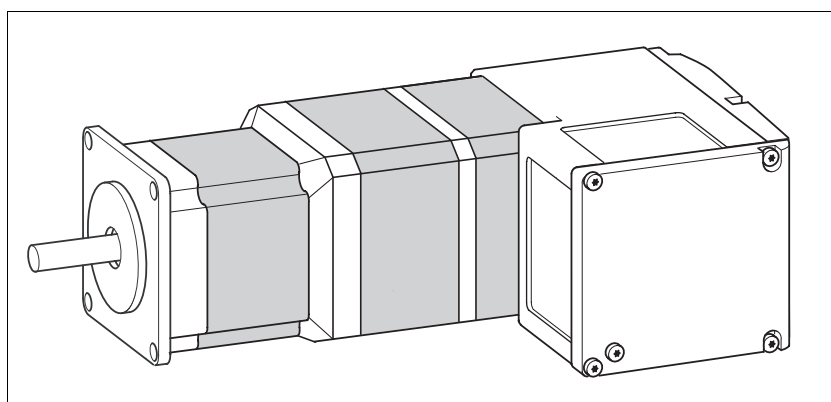

Figure 1.1 Device overview

The "Lexium Integrated Drive" consists of a servo motor and integrated electronics. The product integrates interfaces, control electronics, a holding brake (optional) and the power stage.

Reference value supply

The "Lexium Integrated Drive" moves the motor according to the commands received by a fieldbus master, for example a PLC or a PC.

Safety function

The integrated safety function STO (IEC 61800-5-2) complies with Safety Integrity Level SIL2. The safety function allows for a category 0 stop as per IEC 60204-1 without external power contactors. It is not necessary to interrupt the supply voltage. This reduces the system costs and the response times.

1.3 Components and interfaces

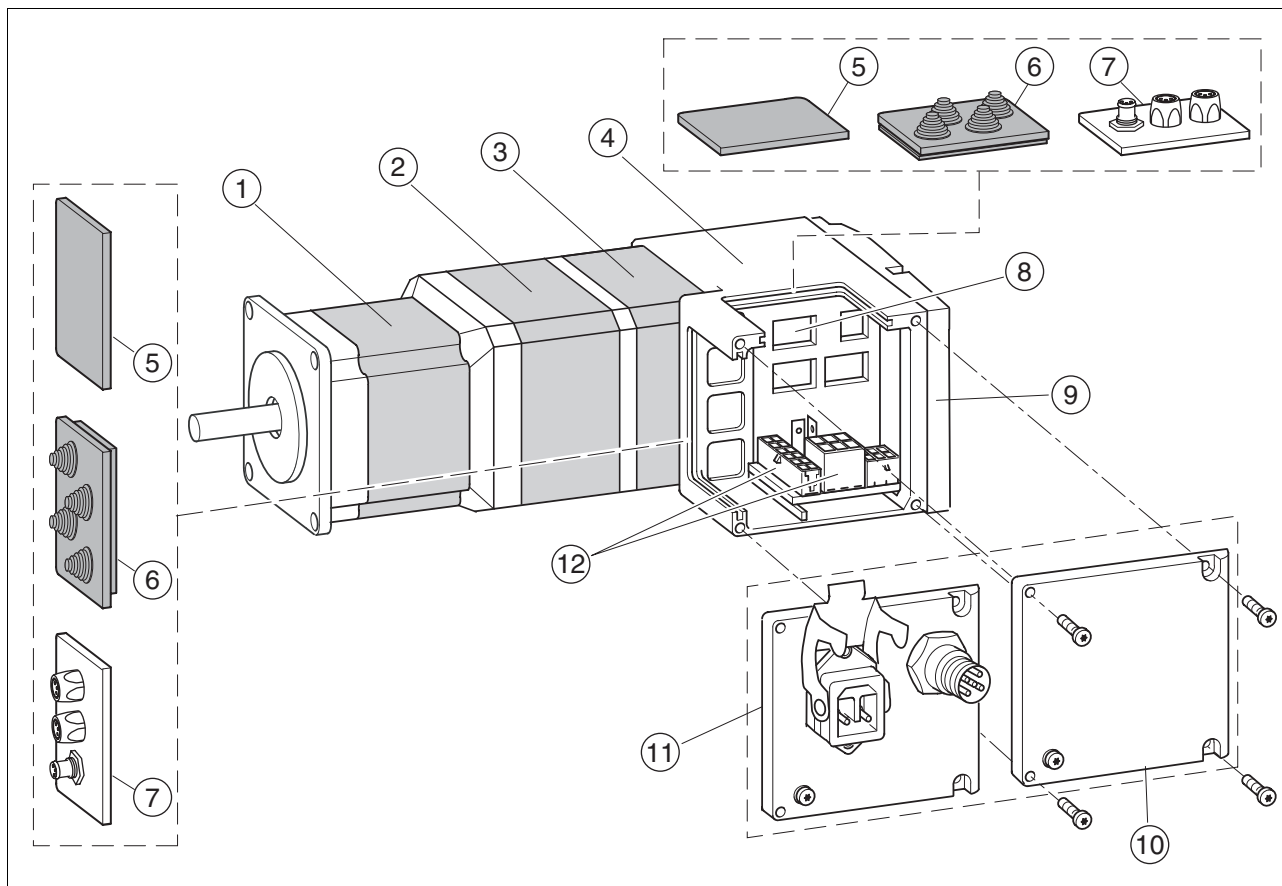

Figure 1.2 Components and interfaces

- (1) AC synchronous servo motor
- (2) Holding brake (optional)
- (3) Encoder
- (4) Electronics housing
- (5) Insert for sealing (accessory)
- (6) Insert with cable entry (accessory)
- (7) I/O insert with industrial connector (accessory)
- (8) Switches for settings
- (9) Cover of electronics housing, must not be removed
- (10) Cover of connector housing, to be removed for installation
- (11) Cover with industrial connector for VDC supply voltage and IN/OUT fieldbus connection (optional)
- (12) Electrical interfaces

1.3.1 Components

<i>Motor</i>	The motor is a brushless AC synchronous servo motor with 3-phase technology. The motor has a high power density due to the use of the latest magnetic materials and an optimized design.
<i>Electronics</i>	<p>The electronic system comprises control electronics and power stage. Control electronics and power stage have a common power supply and are not galvanically isolated.</p> <p>The product can be parameterized and controlled via the fieldbus interface.</p> <p>4 digital 24V signals are also available. Each of these signals can be used as an input or output.</p>
<i>Encoder</i>	<p>The standard product operates with a singleturn encoder.</p> <p>The singleturn encoder has an internal resolution of 32768 increments per revolution.</p> <p>Scaling of the product is set to 16384 user-defined units per revolution.</p> <p>The product can optionally be equipped with a multiturn encoder. The multiturn encoder covers a range of 4096 motor revolutions.</p>
<i>Holding brake</i>	The product can optionally be equipped with an integrated holding brake. The holding brake is controlled automatically.

1.3.2 Interfaces

<i>Supply voltage VDC</i>	The supply voltage VDC supplies the control electronics and the power stage.
<i>Ethernet fieldbus interface</i>	The product features an Ethernet fieldbus interface. This interface is used for controlling and commissioning the drive.
<i>RS485 interface</i>	<p>An RS485 interface is provided in addition to the fieldbus interface. The RS485 interface is also used to commission the product.</p> <p>You can also use the RS485 interface and the commissioning software to monitor the product during operation. It is possible to establish a simultaneous connection with the fieldbus.</p>
<i>24 V signal interface</i>	<p>4 digital 24V signals are available. Each of these signals can be used as an input or output.</p> <p>The 24V signals are available to the master controller. However, it is also possible to parameterize special functions such as connection of limit switches.</p>

1.4 Nameplate

The nameplate contains the following data:

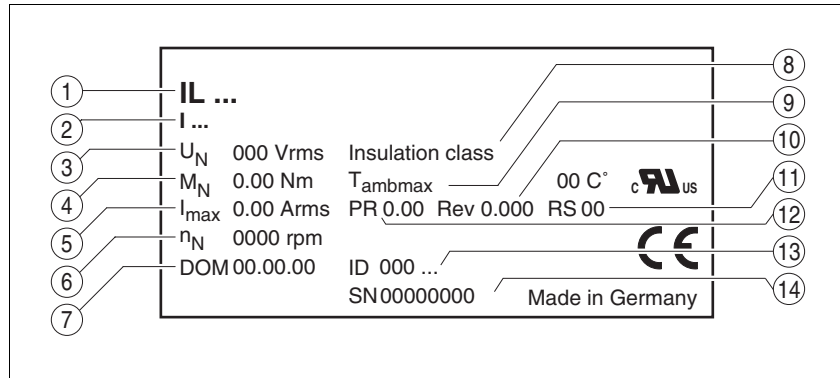

Figure 1.3 Nameplate

- (1) Type code
- (2) Type code (old designation)
- (3) Nominal voltage
- (4) Nominal torque
- (5) Maximum input current
- (6) Nominal speed
- (7) Date of manufacture
- (8) Thermal class
- (9) Maximum ambient air temperature
- (10) Software revision
- (11) Hardware revision
- (12) Firmware number
- (13) Material number
- (14) Serial number

1.5 Type code

	ILA	2	T	57	1	P	B	1	A	0	--
Motor ILA = Servo motor											
Supply voltage 2 = 24 ... 48 V _{dc}											
Communication interface T = Modbus TCP											
Size 57 = 57 mm											
Length 1 = 1 stack 2 = 2 stacks											
Winding P = Medium speed of rotation/medium torque T = High speed of rotation/low torque											
Connection version B = Printed circuit board connector C = Industrial connector											
Position capture 1 = Servo Singleturn 2 = Servo Multiturn ¹⁾ .											
Holding brake A = Without holding brake F = With holding brake ²⁾											
Gearbox 0 = Without gearbox											
Reserved											

1) Not available in combination with the holding brake option
 2) Not available in combination with the servo multiturn option.

Customized product In the case of a customized product, position 9 is an "S".
 Positions 10 ... 13 are the number of the customized product.
 Example: IL●●●●●S1234--

019844113652, V2.00, 11.2008

1.6 Documentation and literature references

- Source product manuals* The current product manuals are available for download from the Internet.
<http://www.schneider-electric.com>
- Source EPLAN Macros* For easier engineering, macro files and product master data are available for download from the Internet at:
<http://www.schneider-electric.com>
- User associations* <http://www.modbus.org>, <http://www.schneider-electric.de>
- Additional literature* We recommend the following literature for more in-depth information:
- Ellis, George: Control System Design Guide. Academic Press
 - Kuo, Benjamin; Golnaraghi, Farid: Automatic Control Systems. John Wiley & Sons
 - Tanenbaum, Andrew S, Computernetzwerke. ISBN: 3-8273-7011-6, Addison-Wesley Verlag Berlin
 - Hunt, Craig, TCP/IP Netzwerk Administration. ISBN: 978-3-89721-179-7, O'Reilly Verlag Köln

1.7 Declaration of conformity



SCHNEIDER ELECTRIC MOTION DEUTSCHLAND GmbH & Co. KG
 Breslauer Str. 7 D-77933 Lahr

EC DECLARATION OF CONFORMITY
YEAR 2008

- according to EC Directive Machinery 98/37/EC
- according to EC Directive EMC 2004/108/EC
- according to EC Directive Low Voltage 2006/95/EC

We declare that the products listed below meet the requirements of the mentioned EC Directives with respect to design, construction and version distributed by us. This declaration becomes invalid with any modification on the products not authorized by us.

Designation: Motors with integrated control electronics

Type: ILA, ILE, ILS

Product number: 0x6600xxxxxxx, 0x6610xxxxxxx, 0x66206xxxxxx, 0x66307xxxxxx
 0x6640xxxxxxx, 0x66606xxxxxx, 0x66707xxxxxx

Applied harmonized standards, especially: EN ISO 13849-1:2006, Performance Level "d" (category 3)
 EN 61800-3:2004, second environment
 EN 62061:2005, SILcl 2
 EN 61508:2001, SIL 2

Applied national standards and technical specifications, especially: UL 508C
 Product documentation

Schneider Electric Motion Deutschland
 GmbH & Co. KG

Company stamp: Postfach 11 80 • D-77901 Lahr
 Breslauer Str. 7 • D-77933 Lahr

Date/ Signature: 10 July 2008

Name/ Department: Wolfgang Brandstätter/Development

019844113652, V2.00, 11.2008

1.8 TÜV certificate for functional safety



019844113652, V2.00, 11.2008

2 Before you begin - safety information

2.1 Qualification of personnel

Only appropriately trained persons who are familiar with and understand the contents of this manual and all other pertinent product documentation are authorized to work on and with this product. In addition, these persons must have received safety training to recognize and avoid hazards involved. These persons must have sufficient technical training, knowledge and experience and be able to foresee and detect potential hazards that may be caused by using the product, by changing the settings and by the mechanical, electrical and electronic equipment of the entire system in which the product is used.

All persons working on and with the product must be fully familiar with all applicable standards, directives, and accident prevention regulations when performing such work.

2.2 Intended use

This product is a motor with an integrated drive and intended for industrial use according to this manual.

The product may only be used in compliance with all applicable safety regulations and directives, the specified requirements and the technical data.

Prior to using the product, you must perform a risk assessment in view of the planned application. Based on the results, the appropriate safety measures must be implemented.

Since the product is used as a component in an entire system, you must ensure the safety of persons by means of the design of this entire system (for example, machine design).

Operate the product only with the specified cables and accessories. Use only genuine accessories and spare parts.

The product must NEVER be operated in explosive atmospheres (hazardous locations, Ex areas).

Any use other than the use explicitly permitted is prohibited and can result in hazards.

2.3 Hazard categories

Safety instructions to the user are highlighted by safety alert symbols in the manual. In addition, labels with symbols and/or instructions are attached to the product that alert you to potential hazards.

Depending on the seriousness of the hazard, the safety instructions are divided into 4 hazard categories.

DANGER

DANGER indicates an imminently hazardous situation, which, if not avoided, **will result** in death or serious injury.

WARNING

WARNING indicates a potentially hazardous situation, which, if not avoided, **can result** in death, serious injury, or equipment damage.

CAUTION

CAUTION indicates a potentially hazardous situation, which, if not avoided, **can result** in injury or equipment damage.

CAUTION

CAUTION used without the safety alert symbol, is used to address practices not related to personal injury (e.g. **can result** in equipment damage).

2.4 Basic information

⚠ DANGER

UNINTENDED CONSEQUENCES OF EQUIPMENT OPERATION

When the system is started, the drives are usually out of the operator's view and cannot be visually monitored.

- Only start the system if there are no persons in the hazardous area.

Failure to follow these instructions will result in death or serious injury.

⚠ WARNING

UNEXPECTED MOVEMENT

Drives may perform unexpected movements because of incorrect wiring, incorrect settings, incorrect data or other errors.

Interference (EMC) may cause unpredictable responses in the system.

- Carefully install the wiring in accordance with the EMC requirements.
- Switch off the voltage at the inputs $\overline{STO_A}$ ($\overline{PWRR_A}$) and $\overline{STO_B}$ ($\overline{PWRR_B}$) to avoid an unexpected restart of the motor before switching on and configuring the product.
- Do not operate the product with unknown settings or data.
- Perform a comprehensive commissioning test.

Failure to follow these instructions can result in death or serious injury.

⚠ WARNING**LOSS OF CONTROL**

- The designer of any control scheme must consider the potential failure modes of control paths and, for certain critical functions, provide a means to achieve a safe state during and after a path failure. Examples of critical control functions are EMERGENCY STOP, overtravel stop, power outage and restart.
- Separate or redundant control paths must be provided for critical functions.
- System control paths may include communication links. Consideration must be given to the implication of unanticipated transmission delays or failures of the link.
- Observe the accident prevention regulations and local safety guidelines. ¹⁾
- Each implementation of the product must be individually and thoroughly tested for proper operation before being placed into service.

Failure to follow these instructions can result in death or serious injury.

1) For USA: Additional information, refer to NEMA ICS 1.1 (latest edition), Safety Guidelines for the Application, Installation, and Maintenance of Solid State Control and to NEMA ICS 7.1 (latest edition), Safety Standards for Construction and Guide for Selection, Installation for Construction and Operation of Adjustable-Speed Drive Systems.

⚠ WARNING**UNEXPECTED BEHAVIOR AND DESTRUCTION OF SYSTEM COMPONENTS**

When you work on the wiring and when you unplug or plug in connectors, this may cause unexpected behavior and destruction of system components.

- Switch the power supply off before working on the wiring.

Failure to follow these instructions can result in death, serious injury or equipment damage.

2.5 Functional safety

Using the safety functions integrated in this product requires careful planning. For more information see chapter 5.4 "Safety function STO ("Safe Torque Off")" on page 48.

2.6 Standards and terminology

Technical terms, terminology and the corresponding descriptions in this manual are intended to use the terms or definitions of the pertinent standards.

In the area of drive systems, this includes, but is not limited to, terms such as "safety function", "safe state", "fault", "fault reset", "failure", "error", "error message", "warning", "warning message", etc.

Among others, these standards include:

- IEC 61800 series: "Adjustable speed electrical power drive systems"
- IEC 61800-7 series: "Adjustable speed electrical power drive systems - Part 7-1: Generic interface and use of profiles for power drive systems - Interface definition"
- IEC 61158 series: "Industrial communication networks - Fieldbus specifications"
- IEC 61784 series: "Industrial communication networks - Profiles"
- IEC 61508 series: "Functional safety of electrical/electronic/programmable electronic safety-related systems"

Also see the glossary at the end of this manual.

3 Technical Data

This chapter contains information on the ambient conditions and on the mechanical and electrical properties of the product family and the accessories.

3.1 Certifications

Product certifications:

Certified by	Assigned number	Validity
TÜV Nord	SAS-1728/08	2013-01-09
UL	File E 153659	

Certified safety function This product has the following certified safety function:

- Safety function STO "Safe Torque Off" (IEC 61800-5-2)

3.2 Ambient conditions

Ambient temperature during operation

The maximum permissible ambient temperature during operation depends on the distance between the devices and the required power. Observe the pertinent instructions in the chapter Installation.

Ambient temperature ¹⁾	[°C]	0 ... 40
Ambient temperature with current reduction of 2 % per Kelvin ¹⁾	[°C]	40 ... 55

1) Limit values with flanged motor (e.g. steel plate 300x300x10 mm)

Ambient conditions transportation and storage

The environment during transport and storage must be dry and free from dust. The maximum vibration and shock load must be within the specified limits.

Temperature	[°C]	-25 ... +70
-------------	------	-------------

Temperature

Max. temperature of power stage ¹⁾	[°C]	105
Max. temperature of motor ²⁾	[°C]	110

1) Can be read via parameter

2) Measured on the surface

Relative humidity

The following relative humidity is permissible during operation:

Relative humidity	[%]	15 ... 85
-------------------	-----	-----------

Installation altitude

The installation altitude is defined as height above sea level.

Installation height without power reduction	[m]	<1000
---	-----	-------

Vibration and shock

Vibration, sinusoidal	As per IEC/EN 60068-2-6 0.15 mm (from 10 Hz ... 60 Hz) 20 m/s ² (from 10 Hz ... 500 Hz)
Shock, semi-sinusoidal	As per IEC/EN 60068-2-27: 150 m/s ² (11 ms)

EMC

Emission	IEC/EN 61800-3: Class C2 EN 61000-6-4 EN 55022: Class A
Noise immunity	IEC/EN 61800-3: Second environ- ment

3.3 Mechanical data

3.3.1 Degree of protection

IP degree of protection The product has the following IP degree of protection as per EN 60529.

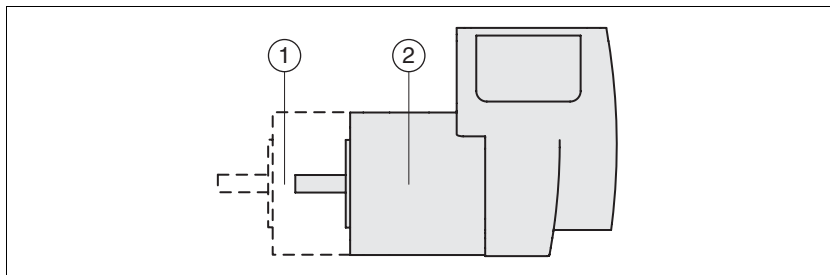

Figure 3.1 IP degree of protection

Item	Degree of protection
1 Shaft bushing	IP41
Shaft bushing with GBX gear (accessory)	IP54
2 Housing, except shaft bushing	IP54

The total degree of protection is determined by the component with the lowest degree of protection.

Overview of IP degrees of protection

First digit	Second digit
Protection against intrusion of objects	Protection against intrusion of water
0 No protection	0 No protection
1 External objects >50 mm	1 Vertically falling dripping water
2 External objects >12 mm	2 Dripping water falling at an angle (75 ° ... 90 °)
3 External objects >2.5 mm	3 Spraying water
4 External objects >1 mm	4 Splashing water
5 Dust-protected	5 Water jets
6 Dust-tight	6 Heavy sea
	7 Immersion
	8 Submersion

Degree of protection if STO is used

You must ensure that conductive substances cannot get into the product (pollution degree 2). If you use the safety function and conductive substances get into the product, the safety function may become inoperative.

019844113652, V2.00, 11.2008

3.3.2 Mounting position

Mounting position The following mounting positions are defined and approved as per EN 60034-7:

- IM B5 drive shaft horizontal
- IM V1 drive shaft vertical, shaft end down
- IM V3 drive shaft vertical, shaft end up

3.3.3 Dimensions

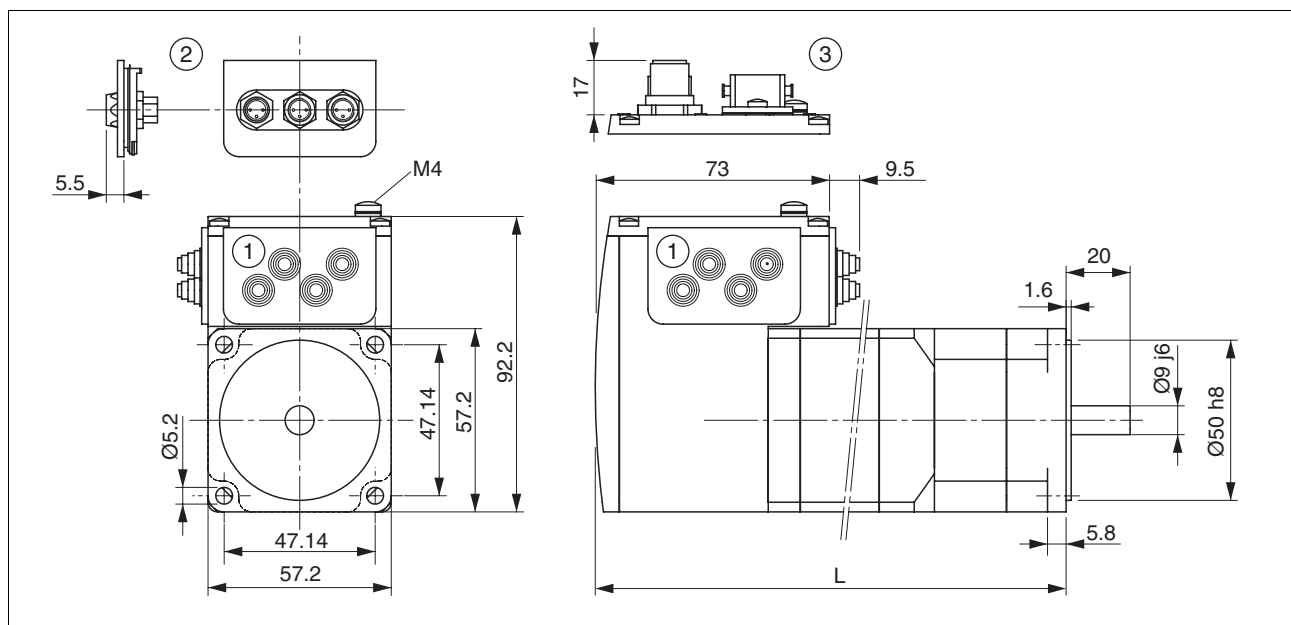

Figure 3.2 Dimensions

- (1) Insert with cable entry (accessory)
- (2) Insert kit (accessory)
- (3) Industrial connector (option)

Total length L

ILA••571...	••1A0	••2A0	••1F0
L [mm]	145.3	179.3	190.8

ILA••572...	••1A0	••2A0	••2F0
L [mm]	163.8	197.8	209.3

3.4 Electrical Data

Overview of printed circuit board connectors

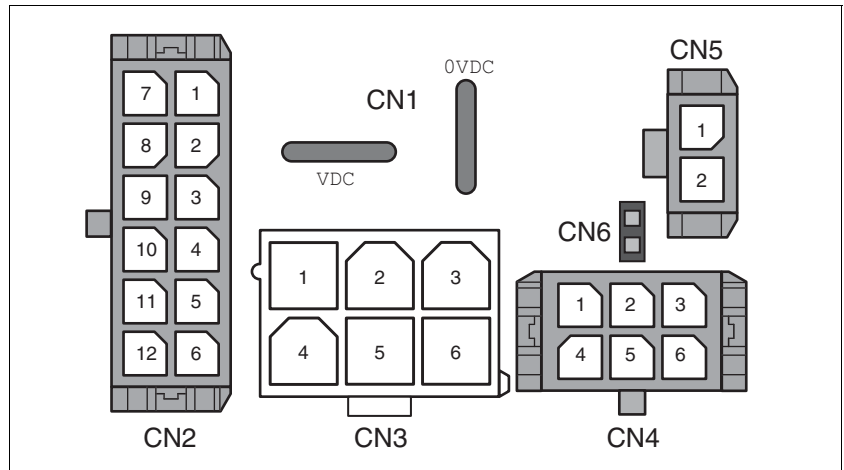

Figure 3.3 Overview of printed circuit board connectors

3.4.1 Supply voltage VDC at CN1

		ILA2•571	ILA2•572
Nominal voltage ¹⁾	[V _{dc}]	24 / 48	24 / 48
Limit values ¹⁾	[V _{dc}]	18 ... 55.2	18 ... 55.2
Ripple at nominal voltage	[V _{pp}]	≤3.6	≤3.6
Max. continuous current input ²⁾	[A]		
Winding type P		5	7
Winding type T		7.5	7.5
Peak input current	[A]		
Winding type P		7	8.5
Winding type T		11	9
Fuse to be connected upstream ³⁾	[A]	≤16	≤16

1) If the product is to be used in compliance with UL 508C, note the information provided in chapter 3.5 "Conditions for UL 508C".

2) The actual power requirement is often significantly lower, because the maximum possible motor torque is usually not required for operation of a system.

3) See chapter 5.2.1 "Supply voltage"

Inrush current Charging current for capacitor C=1500 µF

3.4.2 Fieldbus at CN2

Modbus TCP signals

The Modbus TCP signals comply with the IEEE 802.3 standard and are galvanically isolated.

Transmission rate	[MBit]	10 / 100
Transmission protocol		Modbus TCP

3.4.3 Commissioning at CN3

RS485 signals The RS485 signals comply with the RS485 standard and are not galvanically isolated.

Transmission rate	[kBaud]	9.6 / 19.2 / 38.4
Transmission protocol		Modbus RTU

3.4.4 24V signals at CN4

Signal inputs The signal inputs are not protected against reverse polarity and not galvanically isolated.

Logic 0 (U_{low})	[V]	-3 ... +4.5
Logic 1 (U_{high})	[V]	+15 ... +30
Input current (typical at 24 V)	[mA]	2
Debounce time LIO1 ... LIO4	[ms]	1.25 ... 1.5

Signal outputs The signal outputs are short-circuit protected and not galvanically isolated.

Nominal voltage	[V]	24
Voltage range	[V]	23 ... 25
Maximum current per output	[mA]	100
Maximum total current	[mA]	200
Suitable for inductive loads	[mH]	1000
Voltage drop at 50 mA load	[V]	≤ 1

3.4.5 STO safety function at CN5 and CN6

The signal inputs are not galvanically isolated.

Logic 0 (U_{low})	[V]	-3 ... +4.5
Logic 1 (U_{high})	[V]	+15 ... +30
Input current $\overline{STO_A}$ ($\overline{PWRR_A}$) (typical at 24 V)	[mA]	≤10
Input current $\overline{STO_B}$ ($\overline{PWRR_B}$) (typical at 24 V)	[mA]	≤3
Debounce time	[ms]	1 ... 5
Detection of signal difference between $\overline{STO_A}$ ($\overline{PWRR_A}$) and $\overline{STO_B}$ ($\overline{PWRR_B}$)	[s]	<1
Response time (until shutdown of power stage)	[ms]	<50
Permitted test pulse width of upstream devices	[ms]	<1

*Data for maintenance plan and
safety calculations*

Use the following data of the STO safety function for your maintenance plan and the safety calculations:

Lifetime (IEC 61508)		20 years
SFF (IEC 61508) Safe Failure Fraction	[%]	47
HFT (IEC 61508) Hardware Fault Tolerance Type A subsystem		1
Safety integrity level IEC 61508 IEC 62061		SIL2 SILCL2
PFH (IEC 61508) Probability of Dangerous Hard- ware Failure per Hour	[1/h]	$5.223 \cdot 10^{-9}$
PL (ISO 13849-1) Performance Level		d (Category 3)
MTTF _d (ISO 13849-1) Mean Time to Dangerous Failure		1995 years
DC (ISO 13849-1) Diagnostic Coverage	[%]	90

3.5 Conditions for UL 508C

If the product is used to comply with UL 508C, the following conditions must be met:

- Pollution degree* Use in an environment with pollution degree 2.
- Power supply* Use only power supply units that are approved for overvoltage category III.
- The supply voltage must not exceed $42 V_{dc}$.
- Wiring* Use only 60/75 °C copper conductors.

4 Basics

4.1 Functional safety

Automation and safety engineering are two areas that were completely separated in the past but recently have become more and more integrated. Engineering and installation of complex automation solutions are greatly simplified by integrated safety functions.

Usually, the safety engineering requirements depend on the application. The level of the requirements results from the risk and the hazard potential arising from the specific application.

Working with IEC 61508

IEC 61508 standard

The standard IEC 61508 "Functional safety of electrical/electronic/programmable electronic safety-related systems" covers the safety-related function. Instead of a single component, an entire function chain (for example, from a sensor through the logical processing units to the actuator) is considered as a unit. This function chain must meet the requirements of the specific safety integrity level as a whole. Systems and components that can be used in various applications for safety tasks with comparable risk levels can be developed on this basis.

SIL, Safety Integrity Level

The standard IEC 61508 defines 4 safety integrity levels (SIL) for safety functions. SIL1 is the lowest level and SIL4 is the highest level. A hazard and risk analysis serves as a basis for determining the required safety integrity level. This is used to decide whether the relevant function chain is to be considered as a safety function and which hazard potential it must cover.

PFH, Probability of a dangerous hardware failure per hour

To maintain the safety function, the IEC 61508 standard requires various levels of measures for avoiding and controlling faults, depending on the required SIL. All components of a safety function must be subjected to a probability assessment to evaluate the effectiveness of the measures implemented for controlling faults. This assessment determines the PFH (probability of a dangerous failure per hour) for a safety system. This is the probability per hour that a safety system fails in a hazardous manner and the safety function cannot be correctly executed. Depending on the SIL, the PFH must not exceed certain values for the entire safety system. The individual PFH values of a function chain are added; the total PFH value must not exceed the maximum value specified in the standard.

SIL	PFH at high demand or continuous demand
4	$\geq 10^{-9} \dots < 10^{-8}$
3	$\geq 10^{-8} \dots < 10^{-7}$
2	$\geq 10^{-7} \dots < 10^{-6}$
1	$\geq 10^{-6} \dots < 10^{-5}$

019844113652, V2.00, 11.2008

HFT and SFF Depending on the SIL for the safety system, the IEC 61508 standard requires a specific hardware fault tolerance HFT in connection with a specific proportion of safe failures SFF (safe failure fraction). The hardware fault tolerance is the ability of a system to execute the required safety function in spite of the presence of one or more hardware faults. The SFF of a system is defined as the ratio of the rate of safe failures to the total failure rate of the system. According to IEC 61508, the maximum achievable SIL of a system is partly determined by the hardware fault tolerance HFT and the safe failure fraction SFF of the system.

IEC 61508 distinguishes two types of subsystems (type A subsystem, type B subsystem). These types are specified on the basis of criteria which the standard defines for the safety-relevant components.

SFF	HFT type A subsystem			HFT type B subsystem		
	0	1	2	0	1	2
< 60%	SIL1	SIL2	SIL3	---	SIL1	SIL2
60% ... <90%	SIL2	SIL3	SIL4	SIL1	SIL2	SIL3
90% ... < 99%	SIL3	SIL4	SIL4	SIL2	SIL3	SIL4
≥99%	SIL3	SIL4	SIL4	SIL3	SIL4	SIL4

Fault avoidance measures Systematic errors in the specifications, in the hardware and the software, usage faults and maintenance faults of the safety system must be avoided to the maximum degree possible. To meet these requirements, IEC 61508 specifies a number of measures for fault avoidance that must be implemented depending on the required SIL. These measures for fault avoidance must cover the entire life cycle of the safety system, i.e. from design to decommissioning of the system.

4.2 Modbus TCP technology

4.2.1 Function principle

Modbus TCP is based on Modbus RTU with its specific protocol. Modbus TCP does not send Modbus messages via the serial interface, but by means of the TCP/IP protocol. Lower protocol layers are no longer considered.

The Modbus TCP client (master) connects to the Modbus TCP server (slave). Once the connection is established, the client sends Modbus requests to the server. These requests are processed by the server. The result is returned to the client.

The Modbus TCP protocol and the Modbus RTU protocol are identical. However, the Modbus RTU message is transmitted via TCP/IP. For this purpose, a so-called MBAP header is added, see page 38. A slave ID is no longer required since the server is addressed via its IP address.

4.2.2 Bus topology

Star and tree topologies can be used. It is possible to use hubs or switches. In the case of high bus loads with many devices, it is recommended to use a switches.

The maximum length of a segment is 100 m. A segment consists of devices and hubs. A network can be subdivided into several segments by means of gateways or switches. Short cables and a star topology are recommended to achieve a fast bus cycle.

The transmission rate is 10 or 100 MBit/s in half-duplex mode. If switches are used, transmission is also possible in full duplex mode.

4.2.3 Device model

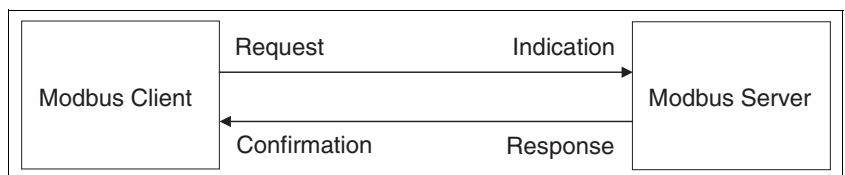

Figure 4.1 Client / server model

The Modbus message service implements client/server communication between devices connected by means of a TCP/IP network. Modbus TCP does not use an object dictionary. The registers are described in chapter 11 "Parameters". The client/server model is based on 4 types of messages:

- A **Modbus request** is a message sent by the client to trigger a transaction.
- A **Modbus indication** is a request received by the server.
- A **Modbus response** is a response sent by the server.
- A **Modbus confirmation** is a response received by the client.

The product is implemented as a Modbus server. The server receives messages from the master (client), processes them and responds to them. The product does not send messages by itself.

The product manages all Modbus packets received via the network and analyzes the Modbus requests to decode the Modbus function code for proper execution.

Depending on the Modbus request, the server triggers operations and actions or provides requested data.

4.2.4 Modbus TCP protocol

A Modbus message is also referred to as a data frame. A message addressed to a server (slave) is referred to as a transmit data frame or request. In response to this request, this device sends a receive data frame.

Request and response have the same structure.

If an error occurs on receipt of the request or if the slave cannot execute the action, the slave sends an error message as the response.

A Modbus TCP data frame consists of the following fields:

<SlaveAddr> <FC> <Data>

Field name	Meaning	Number of bytes
<SlaveAddr>	Slave address	1
<FC>	Function code	1
<Data>	Data	n (high byte, low byte)

<SlaveAddr> Under Modbus TCP, the target device is identified via TCP/IP and the request is sent as a Broadcast. The Modbus TCP data frame contains <SlaveAddr> only for purposes of compatibility with Modbus RTU. <SlaveAddr> is a part of the MBAP header.

<FC> The function code determines the Modbus service the slave is to execute. The function code is the same in both the request and the response.

<Data> Whether a data field is contained in the data frame and what its length is depends on the function code used. The data field of a request contains the control and action commands of the corresponding function code. The data field of a response contains the data requested by the master, depending on the function code. It can also contain an error message.

019844113652, V2.00, 11.2008

4.2.5 Generation of a Modbus response

All function codes described in chapter 4.2.9 "Implemented function codes" are supported.

If a PDU (Protocol Data Unit) with a wrong syntax is transmitted, the connection is cut. In other error cases, a Modbus exception is sent.

The Modbus server generates a response after having processed a request. For this purpose, the Modbus server uses a suitable Modbus server transaction and sends it to the TCP management unit.

Depending on the type of processing, two types of responses are possible:

- Positive Modbus response
 - The function code of the response corresponds to the function code of the request.
- Modbus exception response
 - The client receives pertinent information on error detection during processing;
 - The function code of the response corresponds to the function code of the request + 80_h;
 - The exception code indicates the cause of the error.

Exception code	Modbus name	Remark
01	Illegal Function	The server does not know the function code
02	Illegal Data Address	Depends on the request
03	Illegal Data Value	Depends on the request
04	Server Failure	The server was unable to properly terminate processing.
05	Acknowledge	The server accepted the service request, but its execution takes a relatively long time. The server therefore only returns a confirmation of the service request.
06	Server Busy	The server was unable to accept the Modbus request PDU. It is up to the client application to decide whether and when to return the request.
0A	Gateway Problem	The gateway path is unavailable.
0B	Gateway Problem	The requested device does not respond. The gateway generates the exception.

4.2.6 MBAP header

Comparison to Modbus RTU

There are several differences between the Modbus TCP MBAP header (MBAP = Modbus Application Protocol) and the Modbus RTU ADU (Application Data Unit):

The Modbus field "Slave address" of Modbus RTU is replaced by a single byte, the "Unit Identifier", in the MBAP header. The "Unit Identifier" is used if a Modbus TCP message is to be routed to a Modbus RTU fieldbus. Routers serve as the hardware bridge between Modbus RTU and Modbus TCP.

All Modbus requests and responses are designed in such a way that the recipient can verify whether processing of a message is finished. In the case of function codes with a fixed-length Modbus PDU (Protocol Data Unit), the function code alone is sufficient. For function codes carrying a variable amount of data in the request or response, the data field includes a byte count.

When Modbus is carried over TCP, additional length information is carried in the MBAP header to allow the recipient to recognize message boundaries even if the message has been split into multiple packets for transmission. The existence of explicit and implicit length rules and the use of a CRC-32 error check code (on Ethernet) results in an infinitesimal chance of undetected corruption of a request or response message.

Addressing

Modbus TCP no longer uses the Client Identifier, but the IP address of the Modbus TCP devices to address the devices.

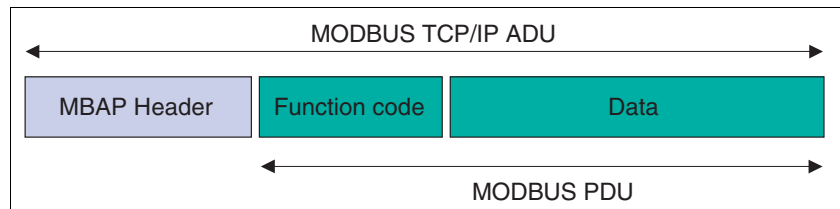

Figure 4.2 Structure of the MBAP header

The MBAP header has a length of 7 bytes and contains the following fields:

Field	Length	Description	Client	Server
Transaction Identifier	2 bytes	Identification of a Modbus request / response transaction	Initialized by client	Copied from request received and returned
Protocol Identifier	2 bytes	0 = Modbus protocol	Initialized by client	Copied from the request received and returned
Length	2 bytes	Number of bytes to follow	Initialized by the client (request)	Initialized by the server (response)
Unit Identifier	1 byte	Identification of a remote slave connected via a serial connection or with a different bus	Initialized by client	Copied from request received and returned

- **Transaction Identifier:** Used for transaction pairing. The Modbus server copies the Transaction Identifier of the request to the response.

- **Protocol Identifier:** The Modbus protocol is identified by the value 0
- **Length:** The length field is a byte counter for the following fields (ID, function codes and data).
- **Unit Identifier:** Used for routing. The field is typically used for communication with a Modbus RTU slave via a Modbus TCP Gateway. This field is set by the Modbus client in the request and returned with the same value in the response by the server.

The maximum size of a Modbus TCP ADU is 260 bytes. The size of an embedded Modbus PDU is 253 bytes.

Note: The fields are encoded in Big Endian (highest-value byte first).

4.2.7 Modbus port

The receive TCP port 502 is assigned to Modbus communication. The port can be configured by means of the commissioning software and Modbus parameters (see chapter 11 "Parameters").

4.2.8 Connection management

<i>Establishing of a connection</i>	The Modbus TCP server allows for TCP connections via the default port 502. A client can establish a new connection via this port. If the client is to exchange data with a remote server, a new client connection via remote port 502 must be established.
<i>Modbus data transfer</i>	<p>A Modbus request is sent via a suitable, open connection. This TCP connection is found using the IP address of the remote device. The connection remains open for all Modbus communication. Up to 8 simultaneous connections are possible.</p> <p>As described in the next chapter, a Modbus client can initialize several Modbus transactions without having to wait for the previous transaction to be finished.</p>
<i>Access control</i>	To perform movement, access must be requested. See chapter 8.2 "Access control".
<i>Closing a connection</i>	<p>After the Modbus communication between the client and a server is finished, the client causes the connection used to be closed.</p> <p>The server does not close the connection under normal circumstances. Exceptions for error and safety reasons comprise:</p> <ul style="list-style-type: none"> • Communication errors • Communication inactivity • Normal/backup reconfiguration • Maximum number of connections reached <p>The product can manage up to 8 TCP connections. If a new connection is requested, the connection not used for the longest time is closed. If this is impossible, the connection request is rejected by the system.</p>

4.2.9 Implemented function codes

The function codes (FC) allow for triggering various communication mechanisms (services) provided by the Modbus protocol. The following table provides an overview of the function codes implemented in the device.

FC	Meaning under Modbus	Meaning from device perspective
3	Read Multiple Registers	Read n Parameters
8	Diagnostics	Diagnostics
16	Write Multiple Registers	Write n Parameters
23	Read/Write Multiple Registers	Read Write n Parameters
43 Subcode14	Read Schneider Identification	–
90	UMAS File Transfer (upload)	–

4.2.10 Reading and writing parameters

Parameters are processed as 32 bit values. 16 bit values must also be processed as 32 bit values. Since Modbus registers have a length of 16 bits, two consecutive registers Modbus registers must be read or written to process a parameter. The first Modbus address must be specified, see chapter 11.2 "Object dictionary".

If n consecutive parameters are to be processed, one Modbus command with the corresponding Modbus address and the length indication 2n is sufficient.

This does not apply to reading Modbus registers in the ranges 6656 (1A00_h) and 6911 (1AFF_h). In these ranges, two separate Modbus commands must be sent.

Example Reading the Modbus TCP ports, Modbus address 6684 (1A1C_h)

When the register 6684 is read and the length specification is 2, the two Modbus registers 6684 and 6685 are read. Result:

Address	Value
6684	0000 _h
6685	01F6 _h

Table 4.1 Reading the Modbus TCP port

The sequence of the words can be changed via the parameter 6410 (190A_h) for the corresponding Modbus TCP connection.

4.2.11 Examples of function codes FC

Example 1 Reading an error memory entry -> FLT_err_num (15362) / FLT_class (15364) / FLT_Time (15366) / FLT_Qual (15368). Since all Modbus error information has consecutive addresses in ascending order, a single read request is sufficient:

Field	Bytes	Value	Meaning
FC (Request Code)	1	3	Request code (Multiple Register READ)
ParamAddress	2	15362dec (3C02 _h)	First parameter address to be read
NumberOfParameters	2	4 * 2 = 8	Number of 16 bit parameters = 8, i.e. 16 bytes of data are to be read

Table 4.2 Example 1, FC3 Request

Field	Bytes	Value	Meaning
FC (Request Code)	1	3	Request code: Multiple Register READ
NumOfBytes	1	16	Number of bytes: 8 bytes of data
Data	16	32 bit value 32 bit value 32 bit value 32 bit value	FLT_err_num, 15362 (error number) FLT_class, 15364 (error class) FLT_Time, 15366 (error time) FLT_Qual, 15368 (error code)

Table 4.3 Example 1, FC3 Positive Response

Example 2 Writing the software limit switch values -> SPVswLimPusr (1544) / SPVswLimNusr (1546). Since these parameters also have consecutive addresses (Modbus address, Modbus address+2), a single write command is sufficient:

Field	Bytes	Value	Meaning
FC (Request Code)	1	16	Request code (Multiple Register WRITE)
ParamAddress	2	1544dec (608 _h)	First parameter address to be written
NumberOfParameters	2	2 * 2 = 4	Number of parameters = 4 (8 bytes of data)
NumOfBytes	1	8	Number of bytes: 8 bytes of data
Data	8	32 bit value 32 bit value	SPVswLimPusr, 1544 SPVswLimNusr, 1546

Table 4.4 Example 2, FC16 Request

Field	Bytes	Value	Meaning
FC (Request Code)	1	16	Response code (Multiple Register WRITE)
ParamAddress	2	1544dec (608 _h)	Modbus parameter address
NumberOfParameters	2	2 * 2 = 4	Number of parameters = 4 (8 bytes of data)

Table 4.5 Example 2, FC16 Positive Response

019844113652, V2.00, 11.2008

4.2.12 I/O Scanning

The I/O Scanning service is used to periodically exchange I/O data between a controller and a device.

The I/O Scanning service must be configured in the controller. The controller uses the following Modbus function codes for the I/O Scanning service:

- FC3 (16#03), Read Multiple Registers
- FC16 (16#10), Write Multiple Registers
- FC23 (16#17), Read-Write Multiple Registers

To use the I/O Scanning service, the Modbus Unit Identifier 255 must be used. This must be configured in the controller.

Only one controller at a time can use the I/O Scanning on the device.

The Modbus register addresses for I/O Scanning do not differ from the register addresses for normal Modbus access.

See also chapters 7.2.6 "Connection monitoring" and 8.6.12 "I/O Scanning".

4.2.13 Faulty Device Replacement (FDR)

The FDR service uses standard DHCP and TFTP (Trivial File Transfer Protocol) technologies to simplify maintenance of Ethernet devices.

For example, the FDR service is used to replace a defective device by a new device. The service allows for detection, configuration and automatic start of the new device without complex manual user interaction.

The main steps:

- A defective device that uses the FDR service is removed.
- The new device that is pre-configured with the "DeviceName" of the defective device is installed in the network.
- The FDR server which can be a Quantum or Premium PLC Ethernet module detects the new device, configures it with its IP address and transmits all configuration parameters.
- The new device verifies full compatibility of the parameters with its properties and then activates the original operating mode.

4.2.13.1 Obtaining the IP address

The IP address can only be obtained via the "DeviceName". See chapter 7.2.2 "Setting the IP address".

4.2.13.2 Configuration file

Information on the configuration file can be found in the manual of the FDR server used (Quantum or Premium).

4.2.14 Network services

4.2.14.1 SNMP

The Internet community has developed the SNMP standard "Simple Network Management Protocol" (RFCs 1155, 1156 and 1157) to support the management of different network devices by means of a single system. The Network Management System can exchange data with SNMP devices. This function allows the manager to monitor the status of the network and the devices, to change their configurations and to trigger warnings if problems occur.

SNMP agent ConneXview

The product only supports SNMP version 1.0. An SNMP agent must be used to monitor a network with SNMP. Schneider Electric offers the tool ConneXview for such purposes..

5 Engineering

This chapter contains information on the application of the product that is vital in the design phase.

5.1 Configurable inputs and outputs

This product has digital inputs and outputs that can be configured. This standard assignment can be adapted to the requirements of the customer's installation. For more information, see chapter 8.6.9 "Configurable inputs and outputs".

5.2 External power supply units

⚠ DANGER

ELECTRIC SHOCK CAUSED BY INCORRECT POWER SUPPLY UNIT

The V_{DC} and $+24V_{DC}$ supply voltages are connected with many exposed signal connections in the drive system.

- Use a power supply unit that meets the PELV (Protective Extra Low Voltage) requirements.
- For North America: Use a power supply unit with a maximum of $42 V_{dc}$ for compliance with UL 508C.
- Connect the negative output of the power supply unit to PE (ground).

Failure to follow these instructions will result in death or serious injury.

5.2.1 Supply voltage

General The power supply unit must be rated for the power requirements of the drive. The input current can be found in the technical data.

The actual power requirements are often significantly lower because the maximum possible motor torque is usually not required for normal operation of a system.

When designing the system, note that the input current of the drive is higher during the motor acceleration phase than during constant movement.

Protection against reverse polarity

In the case of reverse polarity, the supply voltage is short-circuited. The drive is continuous short circuit-proof up to a short-circuit current of a maximum of 15 A. If the power is supplied by a transformer power supply unit, several hundred amperes may flow for a short period of time in the event of reverse polarity; the drive is rated for this and will not be damaged.

Fuse: a circuit-breaker (16 A, trip characteristic B) or a blade fuse (FKS, max. 15 A) or a fuse (5 mm x 20 mm, 10 A slow-blow).

Regeneration condition Note the following for drives with large external mass moments of inertia or for highly dynamic applications:

Motors return regeneration energy during deceleration. The DC bus can store a limited amount of energy in the capacitors. Connecting additional capacitors to the DC bus increases the amount of energy that can be stored.

If the capacity of the capacitors is exceeded, the excess energy must be discharged via internal or external braking resistors. If the energy is not discharged, an overvoltage monitor will shut off the power stage.

Overvoltages can be limited by adding a braking resistor with a corresponding braking resistor controller. This converts the regenerated energy to heat energy during deceleration.

Braking resistor controllers can be found in chapter 12 "Accessories and spare parts". See the product manual for a description of the braking resistor controller.

▲ WARNING

LOSS OF CONTROL DUE TO REGENERATION CONDITION

Regeneration conditions resulting from braking or external driving forces may increase the VDC supply voltage to an unexpected level. Components not rated for this voltage may be destroyed or cause misoperation.

- Verify that all VDC consumers are rated for the voltage occurring during regeneration conditions (for example limit switches).
- Use only power supply units that will not be damaged by regeneration conditions.
- Use a braking resistor controller, if necessary.

Failure to follow these instructions can result in death, serious injury or equipment damage.

Internal 24V signal power supply An internal 24V power supply for the sensor system is integrated in the product.

The internal 24V signal power supply must not be connected to the internal 24V signal power supply of another product.

5.3 Ground design

The ground connections of all interfaces are galvanically connected, including the ground for the VDC supply voltage.

The following points must be considered when you wire the drives in a system:

- The voltage drop in the VDC power supply lines must be kept as low as possible (less than 1 V). At higher ground potential differences between different drives, the communication / control signals may be affected.
- If the distance between the system components is greater, it is recommended to use decentralized power supply units close to the individual drives to supply the VDC voltage. However, the ground connections of the individual power supply units must be connected with the largest possible conductor cross section.
- The internal 24V signal power supply must not be connected in parallel with the internal 24V signal power supply of a different drive.
- If the master controller (e.g. PLC, IPC etc.) does not have galvanically isolated outputs for the drives, you must verify that the current of the VDC supply voltage has no path back to the power supply unit via the master controller. Therefore, the master controller ground may be connected to the VDC supply voltage ground at a single point only. This is usually the case in the control cabinet. The ground contacts of the various signal connectors in the drive are therefore not connected; there is already a connection via the VDC supply voltage ground.
- If the controller has a galvanically isolated interface for communication with the drives, the ground of this interface must be connected to the signal ground of the first drive. This ground may be connected to a single drive only to avoid ground loops. This also applies to a galvanically isolated CAN connection.

Equipotential bonding conductors

Potential differences can result in excessive currents on the cable shields. Use equipotential bonding conductors to reduce currents on the cable shields.

The equipotential bonding conductor must be rated for the maximum current flowing. Practical experience has shown that the following conductor cross sections can be used:

- 16 mm² (AWG 4) for equipotential bonding conductors up to a length of 200 m
- 20 mm² (AWG 4) for equipotential bonding conductors with a length of more than 200 m

5.4 Safety function STO ("Safe Torque Off")

See page 33 for information on using the IEC 61508 standard.

5.4.1 Definitions

<i>Safety function STO (IEC 61800-5-2)</i>	The safety function STO ("Safe Torque Off", "Safe Torque Off") shuts off the motor torque safely. It is not necessary to interrupt the supply voltage. There is no monitoring for standstill.
<i>"Power Removal"</i>	The STO safety function ("Safe Torque Off") is also known as "Power Removal".
<i>Category 0 stop (IEC 60204-1)</i>	Stopping by immediate removal of power to the machine actuators (i.e. an uncontrolled stop).
<i>Category 1 stop (IEC 60204-1)</i>	Controlled stop with power available to the machine actuators to achieve the stop. Power is not interrupted until the stop is achieved.

5.4.2 Function

The STO safety function integrated into the product can be used to implement an "EMERGENCY STOP" (IEC 60204-1) for category 0 stops. With an additional, approved EMERGENCY STOP module, it is also possible to implement category 1 stops.

Function principle The STO safety function is triggered via 2 redundant inputs. The circuits of the two inputs must be separate so that there are always two channels.

The switching process must be simultaneous for both inputs (skew <1s). The power stage is disabled and an error message is generated. The motor can no longer generate torque and coasts down without braking. A restart is possible after resetting the error message with a "Fault Reset".

The power stage is disabled and an error message is generated if only one of the two inputs is switched off or if the skew is too great. This error message can only be reset by switching off the product.

5.4.3 Requirements for using the safety function

⚠ WARNING

LOSS OF SAFETY FUNCTION

Incorrect usage may cause a hazard due to the loss of the safety function.

- Observe the requirements for using the safety function.

Failure to follow these instructions can result in death or serious injury.

<i>Category 0 stop</i>	During a category 0 stop, the motor coasts down in an uncontrolled way. If access to the machine coasting down involves a hazard (results of the hazard and risk analysis), you must take appropriate measures.
<i>Category 1 stop</i>	A controlled stop must be triggered with a category 1 stop. The controlled standstill is not monitored by the drive system. In the case of power outage or an error, a controlled stop is impossible. Final shutoff of the motor is achieved by switching off the two inputs of the STO safety function. The shutoff is usually controlled by a standard EMERGENCY STOP module with a safe time delay.
<i>Behavior of holding brake</i>	Triggering the STO safety function means that the delay time for motors with holding brake is not effective. The motor cannot generate holding torque to bridge the time to application of the holding brake. Especially in the case of vertical axes it is important to verify whether additional measures are required to avoid lowering of the load.
<i>Vertical axes, external forces</i>	If external forces act on the motor (vertical axis) and an unwanted movement, for example caused by gravity, could cause a hazard, the motor must not be operated without additional measures for fall protection.
<i>Unintended restart</i>	To avoid an unexpected restart after restoration of power (e.g. after a power outage), the parameter <code>IO_AutoEnable</code> must be set to "off". Note that a master controller must not trigger an unintended restart.
<i>Degree of protection if STO is used</i>	You must ensure that conductive substances cannot get into the product (pollution degree 2). If you use the safety function and conductive substances get into the product, the safety function may become inoperative.
<i>Protected cable installation</i>	<p>If short circuits or cross circuits can be expected in connection with the two signals of the STO safety function and if they are not detected by upstream devices, protected cable installation is required.</p> <p>In the case of an unprotected cable installation, the two signals of the STO safety function may be connected to external voltage if a cable is damaged. If the two signals are connected to external voltage, the STO safety function is no longer operative.</p>

Protected cable installation possibilities:

- Use separate cables for two signals. Any additional wires in these cables may only carry voltages according to PELV.
- Use a shielded cable. The grounded shield is designed to dissipate the external voltage in the case of damages and to trip the fuse in this way.
- Use a separately grounded shield. If there are other wires in the cable, the two signals must be isolated from these wires by a grounded, separate shield.

Data for maintenance plan and safety calculations

Use the following data of the STO safety function for your maintenance plan and the safety calculations:

Lifetime (IEC 61508)		20 years
SFF (IEC 61508) Safe Failure Fraction	[%]	47
HFT (IEC 61508) Hardware Fault Tolerance Type A subsystem		1
Safety integrity level IEC 61508 IEC 62061		SIL2 SILCL2
PFH (IEC 61508) Probability of Dangerous Hardware Failure per Hour	[1/h]	$5.223 \cdot 10^{-9}$
PL (ISO 13849-1) Performance Level		d (Category 3)
MTTF _d (ISO 13849-1) Mean Time to Dangerous Failure		1995 years
DC (ISO 13849-1) Diagnostic Coverage	[%]	90

Hazard and risk analysis

As a system manufacturer you must conduct a hazard and risk analysis of the entire system. The results must be taken into account in the application of the STO safety function.

The type of circuit resulting from the analysis may differ from the following application examples. Additional safety components may be required. The results of the hazard and risk analysis have priority.

5.4.4 Application examples STO

Example of category 0 stop Application without EMERGENCY STOP module, category 0 stop.

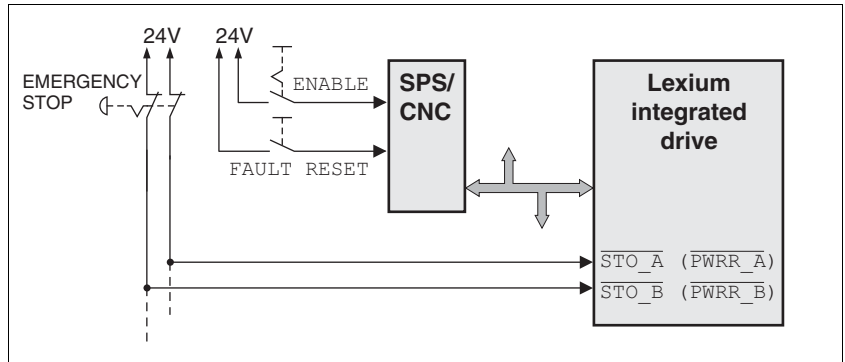

Figure 5.1 Example of category 0 stop

Please note:

- When the EMERGENCY STOP switch is tripped, this initiates a category 0 stop

Example of category 1 stop Application with EMERGENCY STOP module, category 1 stop.

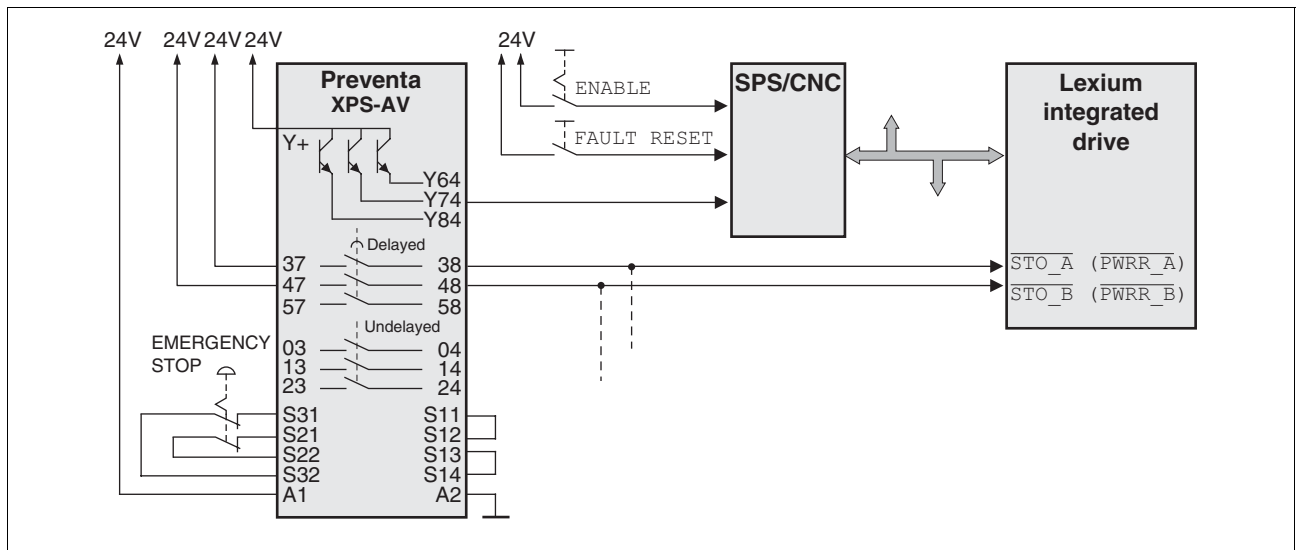

Figure 5.2 Example of category 1 stop

Please note:

- The master controller must immediately trigger a controlled stop, e.g. via the "Quick Stop" function.
- The inputs $\overline{STO_A}$ ($\overline{PWRR_A}$) and $\overline{STO_B}$ ($\overline{PWRR_B}$) must be switched off with a time delay. The delay is set at the EMERGENCY STOP safety module. If the motor has not yet stopped when the delay time has elapsed, it coasts down in an uncontrolled way (uncontrolled stop).
- The specified minimum current and the permissible maximum current of the relay must be observed if the relay outputs of the EMERGENCY STOP module are used.

019844113652, V2.00, 11.2008

5.5 Monitoring functions

The monitoring functions in the product can help to guard the system and reduce the risks involved in a system misoperation. These monitoring functions may not be used to protect persons.

The following monitoring functions are available:

Monitoring	Task
Data link	Error response if the link becomes inoperative
Limit switch signals	Monitors for permissible range of travel
I^2t limitation	Power limitation in event of overloading
Tracking error	Monitors for difference between actual motor position and reference position
Overvoltage and undervoltage	Monitors for overvoltage and undervoltage of the supply voltage
Motor overload	Monitors for excessively high current in the motor phases
Overtemperature	Monitors the device for overtemperature

For a description of the monitoring functions, see chapter 8.6.1 "Monitoring functions", page 152.

6 Installation

▲ WARNING

LOSS OF CONTROL

- The designer of any control scheme must consider the potential failure modes of control paths and, for certain critical functions, provide a means to achieve a safe state during and after a path failure. Examples of critical control functions are EMERGENCY STOP, overtravel stop, power outage and restart.
- Separate or redundant control paths must be provided for critical functions.
- System control paths may include communication links. Consideration must be given to the implication of unanticipated transmission delays or failures of the link.
- Observe the accident prevention regulations and local safety guidelines.¹⁾
- Each implementation of the product must be individually and thoroughly tested for proper operation before being placed into service.

Failure to follow these instructions can result in death or serious injury.

1) For USA: Additional information, refer to NEMA ICS 1.1 (latest edition), Safety Guidelines for the Application, Installation, and Maintenance of Solid State Control and to NEMA ICS 7.1 (latest edition), Safety Standards for Construction and Guide for Selection, Installation for Construction and Operation of Adjustable-Speed Drive Systems.

▲ CAUTION

RISK OF INJURY WHEN THE PRINTED CIRCUIT BOARD CONNECTORS ARE REMOVED

- Before removing the connectors, you must unlocked them.
 - Supply voltage ∇ DVC:
Unlock by pulling at the connector housing
 - Others:
Unlock by pressing the connector lock
- Only pull the connector housing (not the cable).

Failure to follow these instructions can result in injury or equipment damage.



The chapter Engineering contains basic information that you should know before starting the installation.

6.1 Electromagnetic compatibility, EMC

⚠ WARNING

SIGNAL AND DEVICE INTERFERENCE

Signal interference can cause unexpected responses of device.

- Install the wiring in accordance with the EMC requirements.
- Verify compliance with the EMC requirements.

Failure to follow these instructions can result in death, serious injury or equipment damage.

Limit values This product meets the EMC requirements according to the standard IEC 61800-3, if the measures described in this manual are implemented during installation.

If the selected composition is not designed for category C1, note the following:

⚠ WARNING

HIGH-FREQUENCY INTERFERENCE

In a domestic environment this product may cause high-frequency interference that may require action to suppress interference.

Failure to follow these instructions can result in death or serious injury.

EMC measures	Effect
Keep cables as short as possible. Do not install unnecessary cable loops, use short cables from the star point in the control cabinet to the external ground connection.	Reduces capacitive and inductive interference.
Ground the product via the motor flange or with a ground strap to the ground connection at the cover of the connector housing.	Reduces emissions, increases immunity.
Ground shields of digital signal wires at both ends by connecting them to a large surface or via conductive connector housings.	Reduces interference affecting the signal wires, reduces emissions
Connect large surface areas of cable shields, use cable clamps and ground straps	Reduces emissions.

Shielding The following cables must be shielded:

- Fieldbus cable
- STO safety function, see the requirements in chapter 5.4.3 "Requirements for using the safety function".

The following cables do not need to be shielded:

- Supply voltage VDC
- 24 V signal interface

Equipotential bonding conductors

Potential differences can result in excessive currents on the cable shields. Use equipotential bonding conductors to reduce currents on the cable shields.

The equipotential bonding conductor must be rated for the maximum current flowing. Practical experience has shown that the following conductor cross sections can be used:

- 16 mm² (AWG 4) for equipotential bonding conductors up to a length of 200 m
- 20 mm² (AWG 4) for equipotential bonding conductors with a length of more than 200 m

6.2 Mechanical installation

⚠ CAUTION

HOT SURFACES

Depending on the operation, the surface may heat up to more than 100°C (212°F).

- Do not allow contact with the hot surfaces.
- Do not allow flammable or heat-sensitive parts in the immediate vicinity.
- Consider the measures for heat dissipation described.
- Check the temperature during test runs.

Failure to follow these instructions can result in injury or equipment damage.

⚠ WARNING

MOTOR DAMAGE AND LOSS OF CONTROL

Shock or strong pressure applied to the motor shaft may destroy the motor.

- Protect the motor shaft during handling and transportation.
- Avoid shocks to the motor shaft during mounting.
- Do not press parts onto the shaft. Mount parts to the shaft by glueing, clamping, shrink-fitting or screwing.

Failure to follow these instructions can result in death, serious injury or equipment damage.

⚠ WARNING

MOTOR WITHOUT BRAKING EFFECT

If power outage and faults cause the power stage to be switched off, the motor is no longer stopped by the brake and may increase its speed even more until it reaches a mechanical stop.

- Verify the mechanical situation.
- If necessary, use a cushioned mechanical stop or a suitable brake.

Failure to follow these instructions can result in death, serious injury or equipment damage.

▲ WARNING**LOSS OF BRAKING FORCE DUE TO WEAR OR HIGH TEMPERATURE**

Applying the holding brake while the motor is running will cause excessive wear and loss of the braking force. Heat decreases the braking force.

- Do not use the brake as a service brake.
- Note that "EMERGENCY STOPS" may also cause wear
- At operating temperatures of more than 80°C (176°F), do not exceed a maximum of 50% of the specified holding torque when using the brake.

Failure to follow these instructions can result in death, serious injury or equipment damage.



To install a drive in locations difficult to access, it may be useful to carry out the electrical installation first and then install the fully wired drive.

Heat dissipation

The motor may become very hot, for example in the case of incorrect arrangement of multiple motors. The surface temperature of the motor must not exceed 110 °C during continuous operation.

- Verify that the maximum temperature is not exceeded.
- Verify that there is sufficient heat dissipation, for example by means of good ventilation or heat dissipation via the motor flange.

Mounting

The motor is designed to be mounted using four M5 screws. The motor flange must be mounted on a flat surface to avoid mechanical tension from being transmitted to the housing.

Painted surfaces have an insulating effect. During mounting verify that the motor flange is mounted in such a way as to allow for good conductivity (electrical and thermal).

Mounting distances

No minimum clearances are required for installation. However, note that the motor can become very hot.

Observe the bending radii of the cables used.

Ambient conditions

Observe the permissible ambient conditions.

6.3 Electrical installation

⚠ WARNING

UNEXPECTED BEHAVIOR CAUSED BY FOREIGN OBJECTS

Foreign objects, deposits or humidity can cause unexpected behavior.

- Keep foreign objects from getting into the product.
- Do not remove the cover of the electronics housing. Only remove the connector housing cover.
- Verify correct seat of seals and cable entries.

Failure to follow these instructions can result in death, serious injury or equipment damage.

⚠ WARNING

LOSS OF SAFETY FUNCTION CAUSED BY FOREIGN OBJECTS

Conductive foreign objects, dust or liquids may cause the STO safety function to become inoperative.

- Do not use the STO safety function unless you have protected the system against contamination by conductive substances.

Failure to follow these instructions can result in death or serious injury.

⚠ WARNING

DAMAGE TO SYSTEM COMPONENTS AND LOSS OF CONTROL

Interruptions of the negative connection of the controller supply voltage can cause excessively high voltages at the signal connections.

- Do not interrupt the negative connection between the power supply unit and load with a fuse or switch.
- Verify correct connection before switching on.
- Do not connect the controller supply voltage or change its wiring while the is supply voltage present.

Failure to follow these instructions can result in death, serious injury or equipment damage.



The chapter Engineering contains basic information that you should know before starting the installation.

6.3.1 Wiring examples

The following figure shows a typical wiring example. The limit switches and the reference switch are supplied via the internal 24V signal power supply.

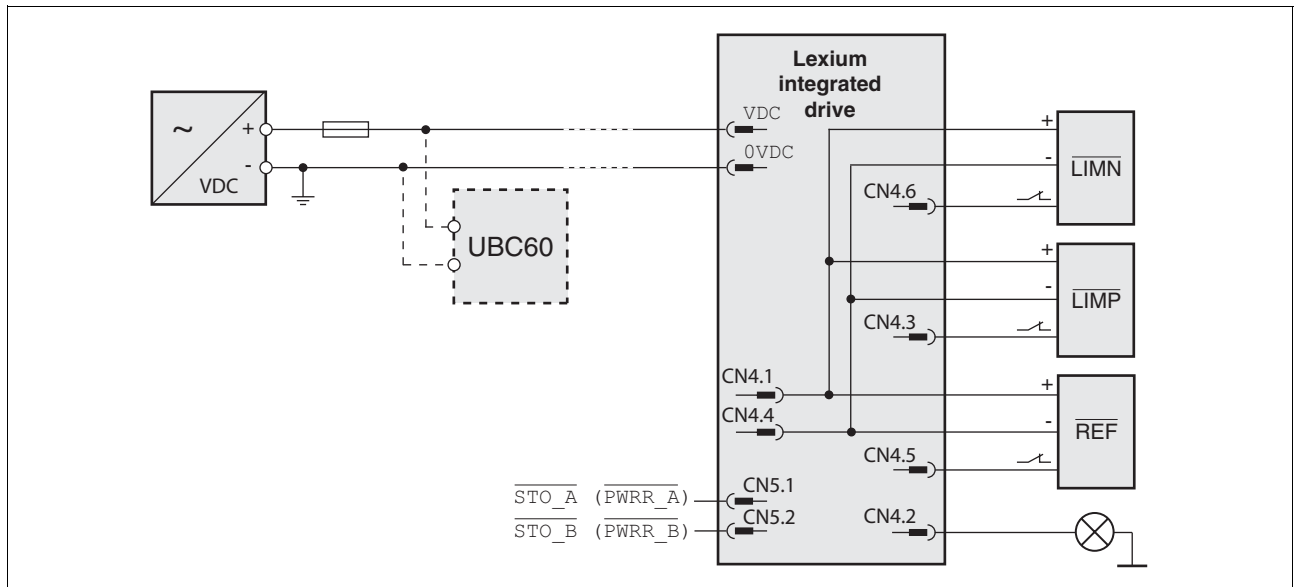

Figure 6.1 Wiring example

The UBC60 braking resistor controller is available as an accessory, see chapter 12 "Accessories and spare parts".

6.3.2 Overview of all connections

Overview of printed circuit board connectors

The following figure shows the pin assignment of the interfaces with the connector housing cover open.

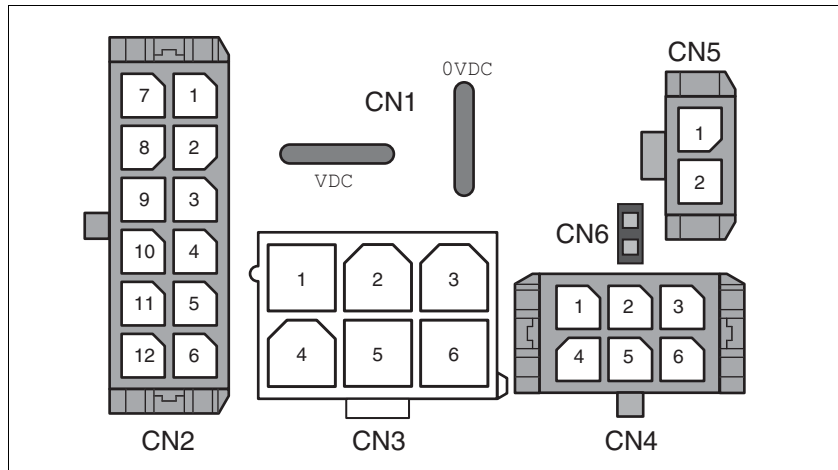

Figure 6.2 Overview of all connections

Connection	Assignment
CN1	Supply voltage \sqrt{VDC}
CN2	Fieldbus interface and reference value supply (for Electronic Gear operating mode)
CN3	Commissioning interface
CN4	24V signals
CN5	Safety function STO "Safe Torque Off" (IEC/EN 61800-5-2)
CN6	Jumper for disabling STO safety function

The drive can be connected via cable entries or industrial connectors.

For connection via cable entries see page 61.

For connection via industrial connectors see page 64.

6.3.3 Connection via cable entry

The cable specifications and pin assignments can be found in the chapters that describe the connections.

Preparing and fastening cables

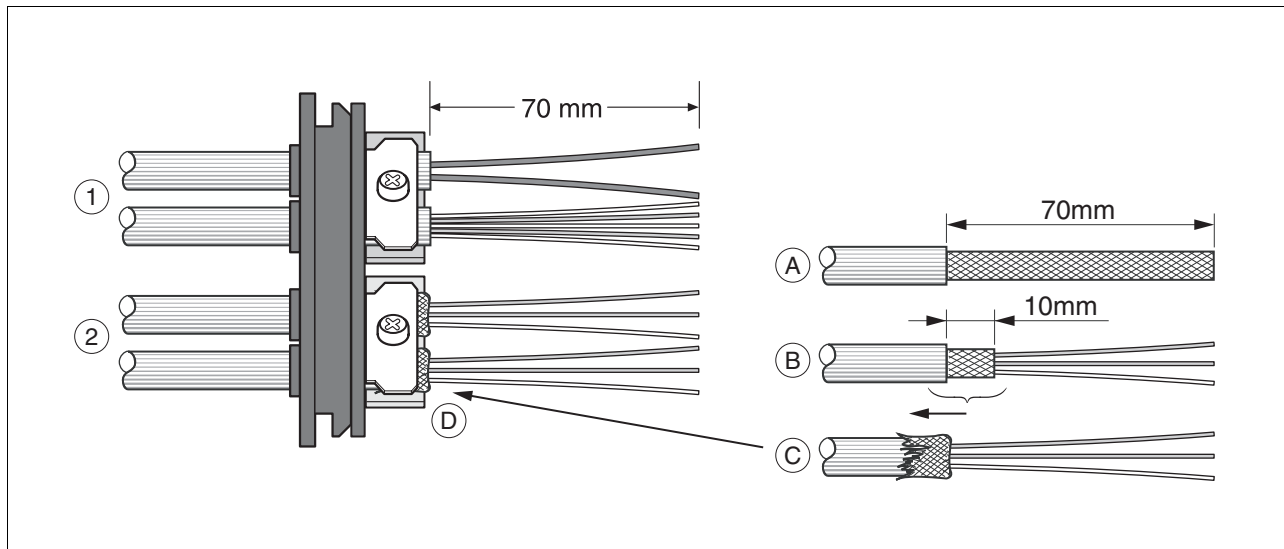

Figure 6.3 Fastening the cable in the cable entry

- (1) Unshielded cable
- (2) Shielded cable

▶ Trim the cable bushings to fit the cable.

NOTE: The specified degree of protection IP54 can only be achieved with properly trimmed cable bushings.

- ▶ (A) Strip the jacket of all cables; length 70 mm.
- ▶ (B) Shorten the shield to a rest of 10 mm.
- ▶ (C) Slide the shield braiding back over the cable jacket.
- ▶ (D) Loosen the strain relief.
- ▶ Push the cables through the strain relief.
- ▶ Glue EMC shielding foil around the shield.
- ▶ Pull the cable back to the strain relief.
- ▶ Fasten the strain relief.

Mounting connectors

The table below lists the parts and data required for assembly. Connector housings and crimp contacts are included in the accessories kit. See also chapter 12 "Accessories and spare parts".



Only use the special tool listed in the Accessories chapter to release single crimp contacts from the connector housing.

Connection	Conductor cross section of the crimp contact [mm ²]	Stripping length [mm]	Manufacturer's crimp contact no.	Crimping tool	Connector manufacturer	Connector type
CN1	0.75 ... 1.5 (AWG 18 ... 16) 2.5 ... 4.0 (AWG 12)	5 ... 65 ... 6	160773-6 341001-6	654174-1	Tyco Electronics	Positive Lock 1-926 522-1
CN2	0.14 ... 0.6 (AWG 24 ... 20)	2.5 ... 3.0	43030-0007	69008-0982	Molex	Micro-Fit 3.0 43025-1200
CN3	0.25 ... 1.0 (AWG 24 ... 18)	3.0 ... 3.5	39-00-0060	69008-0724	Molex	Mini-Fit Jr. 39-01-2065
CN4	0.14 ... 0.6 (AWG 24 ... 20)	2.5 ... 3.0	43030-0007	69008-0982	Molex	Micro-Fit 3.0 43025-0600
CN5	0.14 ... 0.6 (AWG 24 ... 20)	2.5 ... 3.0	43030-0007	69008-0982	Molex	Micro-Fit 3.0 43645-0200

Prepare the cable for connection as follows:

- ▶ Strip the ends of the cable.
- ▶ Attach cable lugs and crimp contacts. Verify that you have the correct crimp contacts and the matching crimping tool.
- ▶ Slide the cable lugs and crimp contacts straight into the connector until they snap in place.

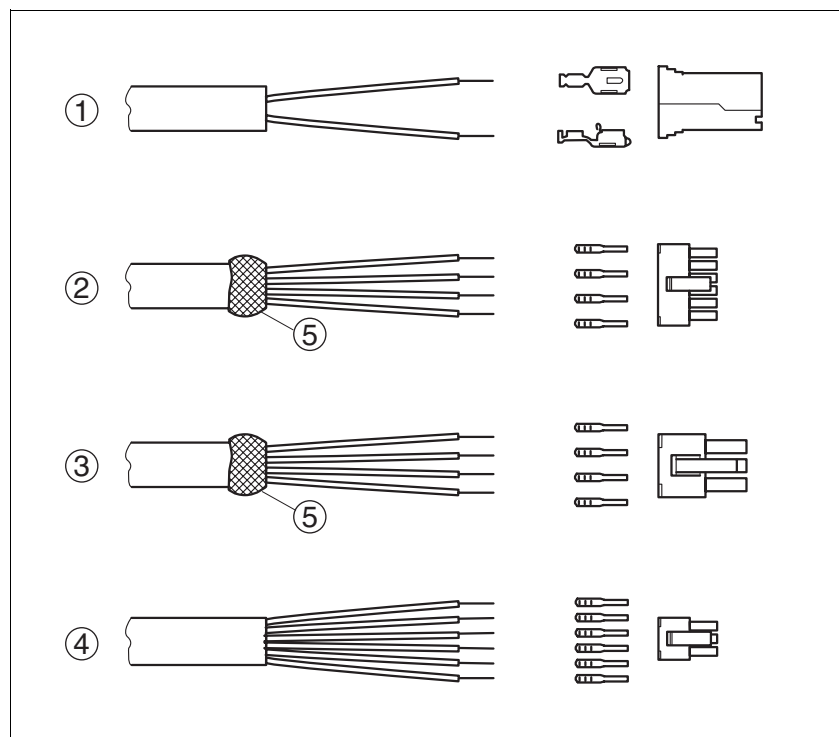

Figure 6.4 Connectors, cable lugs and crimp contacts

- (1) CN1 supply voltage VDC
- (2) CN2 fieldbus
- (3) CN3 commissioning
- (4) CN4 24V signals
- (5) Shield wire with EMC shield foil

Mounting the cable entry

Figure 6.5 Inserting the cable entries

- ▶ Unscrew the connector housing cover.
NOTE: Shipping locks made of cardboard must not be used for operating the drive. Replace all shipping locks by cable entries or signal inserts.
- ▶ First adjust the parameter switches as these are difficult to access once the cables are connected.
For a description of the parameter switches, see the chapters describing the connections.
- ▶ Connect the plug of the assembled cable to the matching socket. The plugs cannot be turned out of position and must click into place when being plugged in.
Only pull the connector housing (not the cable).
- ▶ Plug the cable entry in one of the two cutouts provided. The side to be used for the cable entry depends on the space available in your system.

NOTE: The pointed corners of the cable entry must point in the direction of the connector housing cover. Degree of protection IP54 is not reached if the cable entry is mounted the other way around.

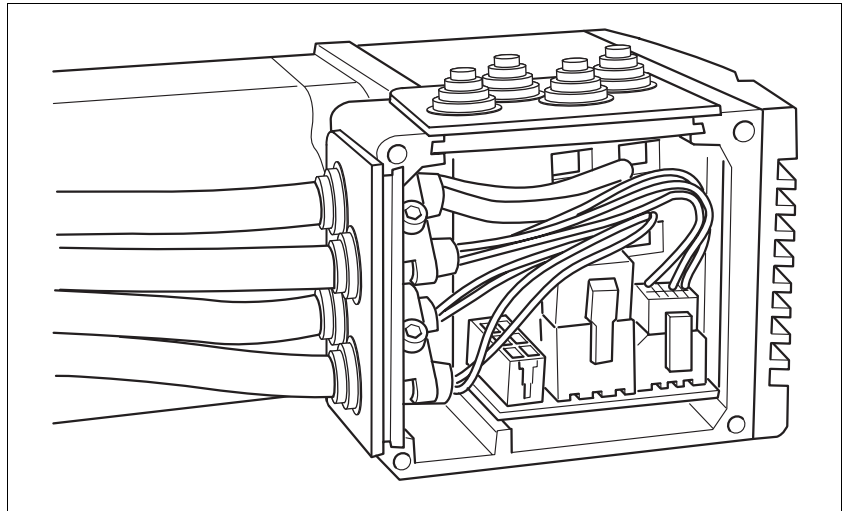
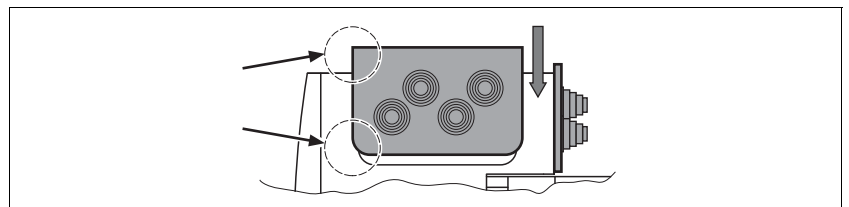

- ▶ Close the cutout that is not used with a sealing insert for cutouts.
- ▶ Finally, screw the connector housing cover back into place.
If screws are lost use M3x12 only.

6.3.4 Connection with industrial connectors

Interface	Connector used
Supply voltage VDC	Hirschmann STASEI 200
Ethernet fieldbus	Circular connector M12, 4 poles, D-codes
24V signal inputs and outputs	Circular connector M8, 3 poles
Safety function STO "Safe Torque Off" (IEC/EN 61800-5-2)	Circular connector M8, 4 poles

Because the requirements are different depending on the system configuration, pre-assembled cables specially designed for Ethernet fieldbus connections can be procured from various suppliers.

Information on pre-assembled cables, connector kits and recommended suppliers can be found in chapter 12 "Accessories and spare parts".

6.3.5 Connection of V_{DC} supply voltage

⚠ DANGER

ELECTRIC SHOCK CAUSED BY INCORRECT POWER SUPPLY UNIT

The V_{DC} and $+24V_{DC}$ supply voltages are connected with many exposed signal connections in the drive system.

- Use a power supply unit that meets the PELV (Protective Extra Low Voltage) requirements.
- For North America: Use a power supply unit with a maximum of $42 V_{dc}$ for compliance with UL 508C.
- Connect the negative output of the power supply unit to PE (ground).

Failure to follow these instructions will result in death or serious injury.

⚠ WARNING

LOSS OF CONTROL DUE TO REGENERATION CONDITION

Regeneration conditions resulting from braking or external driving forces may increase the V_{DC} supply voltage to an unexpected level. Components not rated for this voltage may be destroyed or cause misoperation.

- Verify that all V_{DC} consumers are rated for the voltage occurring during regeneration conditions (for example limit switches).
- Use only power supply units that will not be damaged by regeneration conditions.
- Use a braking resistor controller, if necessary.

Failure to follow these instructions can result in death, serious injury or equipment damage.

CAUTION

DAMAGE TO CONTACTS

The connection for the controller supply voltage at the product does not have an inrush current limitation. If the voltage is switched on by means of switching of contacts, damage to the contacts or contact welding may result.

- Use a power supply unit that limits the peak value of the output current to a value permissible for the contact.
- Switch the power input of the power supply unit instead of the output voltage.

Failure to follow these instructions can result in equipment damage.

▲ WARNING**DAMAGE TO SYSTEM COMPONENTS AND LOSS OF CONTROL**

Interruptions of the negative connection of the controller supply voltage can cause excessively high voltages at the signal connections.

- Do not interrupt the negative connection between the power supply unit and load with a fuse or switch.
- Verify correct connection before switching on.
- Do not connect the controller supply voltage or change its wiring while the is supply voltage present.

Failure to follow these instructions can result in death, serious injury or equipment damage.

Cable specifications and terminal

Two different crimp contacts are available for different conductor cross sections, see chapter 6.3.3 "Connection via cable entry".

Minimum conductor cross section	[mm ²]	0.75 (AWG 18)
Maximum connection cross section	[mm ²]	4.0 (AWG 12)
Stripping length	[mm]	5 ... 65 ... 6
<hr/>		
Crimp contact 1607736-6	[mm ²]	
Minimum connection cross section		0.75 (AWG 18)
Maximum connection cross section		1.5 (AWG 16)
<hr/>		
Crimp contact 341001-6	[mm ²]	
Minimum connection cross section		2.5 (AWG 12)
Maximum connection cross section		4.0 (AWG 12)

Unshielded cables may be used for the VDC supply voltage. Twisted pair is not required.

- ▶ Use pre-assembled cables to reduce the risk of wiring errors.
- ▶ Verify that wiring, cables and connected interfaces meet the PELV requirements.

Connecting the cables

- ▶ Note the specified technical data.
- ▶ Note the information provided in chapters 5.2 "External power supply units" and 5.3 "Ground design".
- ▶ Install fuses for the power supply cable accordance with the selected conductor cross section / wire gauge (note the inrush currents).

Pin assignment printed circuit board connector

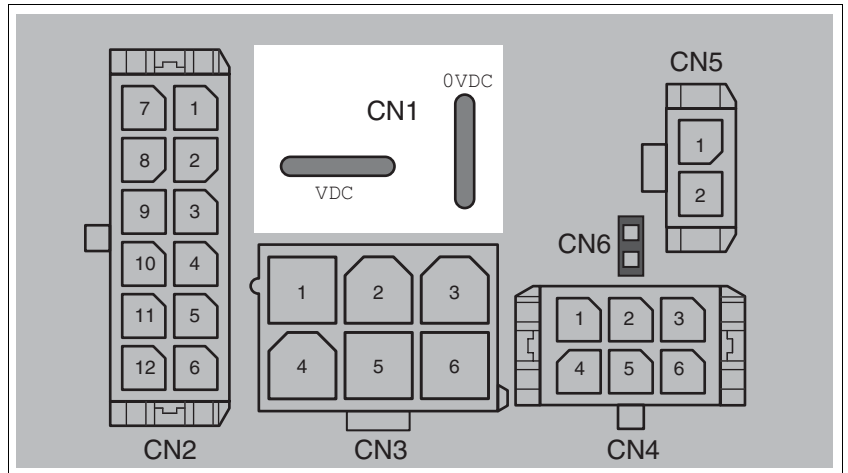

Figure 6.6 Pin assignment supply voltage

Signal	Meaning	Number ¹⁾
VDC	Supply voltage	1
0VDC	Reference potential to VDC	2

1) Information relates to pre-assembled cables

You can crimp together two wires to supply multiple drives via one DC bus. Two different crimp contacts are available for different conductor cross sections, see chapter 6.3.3 "Connection via cable entry".

Pin assignment industrial connector

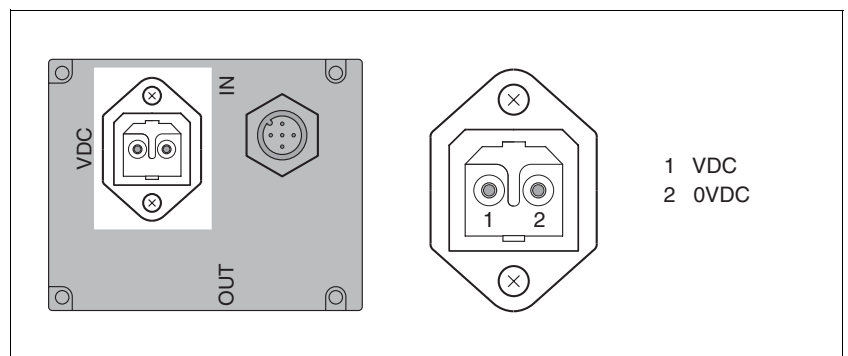

Figure 6.7 Pin assignment supply voltage

Pin	Signal	Meaning	Number ¹⁾
1	VDC	Supply voltage	1
2	0VDC	Reference potential to VDC	2

1) Information relates to pre-assembled cables

019844113652, V2.00, 11.2008

6.3.6 Connection to Ethernet fieldbus interface

Function The Ethernet fieldbus interface allows you to network the product as a slave in an Ethernet network.

The fieldbus is connected by means of printed circuit board connectors or industrial connectors.

- Cable specifications**
- ▶ Use equipotential bonding conductors, see page 55.
 - ▶ Use pre-assembled cables to reduce the risk of wiring errors.
 - ▶ Verify that wiring, cables and connected interfaces meet the PELV requirements.

Pin assignment industrial connector

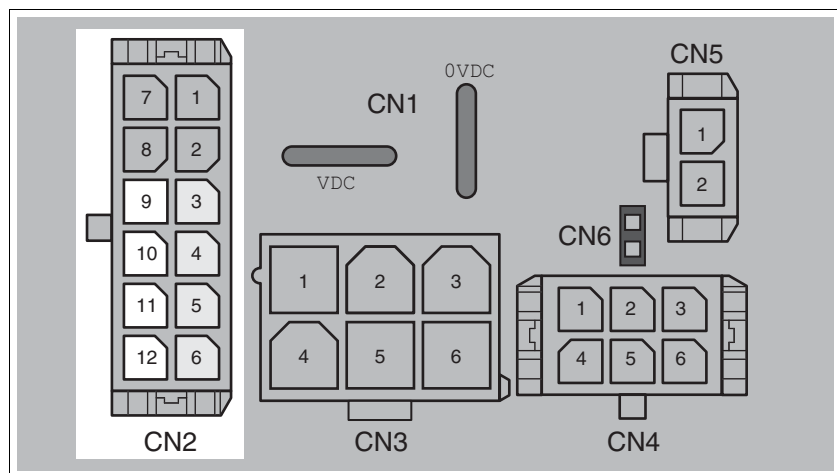

Figure 6.8 Pin assignment printed circuit board connector

Pin	Signal	Meaning (from the perspective of the drive)
CN2.9	Tx+	Fieldbus Tx+
CN2.10	Tx-	Fieldbus Tx-
CN2.11	Rx+	Fieldbus Rx+
CN2.12	Rx-	Fieldbus Rx-

Pin assignment industrial connector

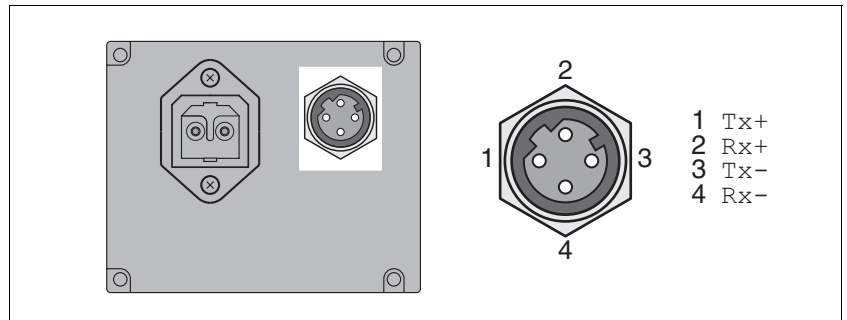

Figure 6.9 Pin assignment industrial connector

Pin	Signal	Meaning
1	Tx+	Fieldbus Tx+ (internally connected to CN2.9)
2	Rx+	Fieldbus Rx+ (internally connected to CN2.11)
3	Tx-	Fieldbus Tx- (internally connected to CN2.10)
4	Rx-	Fieldbus Rx- (internally connected to CN2.12)

D-coded M12.

Setting the address

Each device on the network is identified by a unique, adjustable node address.

Setting the address is explained in the commissioning chapter, see: Chapter 7.2.2 "Setting the IP address"

6.3.7 RS485 interface connection

Function An RS485 interface is provided in addition to the fieldbus interface. The RS485 interface is also used to commission the drive.

You can also use the RS485 interface and the commissioning software to monitor the drive during operation. It is possible to establish a simultaneous connection with the fieldbus.

Cable specifications and terminal

- Shielded cable
- Twisted-pair cables
- Grounding of the shield at both ends

Maximum cable length	[m]	400
Minimum conductor cross section	[mm ²]	0.25 (AWG 22)
Maximum connection cross section	[mm ²]	1.0 (AWG 18)
Stripping length	[mm]	3.0 ... 3.5

- ▶ Use equipotential bonding conductors, see page 55.
- ▶ Use pre-assembled cables to reduce the risk of wiring errors.
- ▶ Verify that wiring, cables and connected interfaces meet the PELV requirements.

Setting the address The node address, baud rate and data format are set using parameters.

Factory settings:

- Node address: 1
- Baud rate: 19200
- Data format: 8 bit, even parity, 1 stop

Pin assignment printed circuit board connector

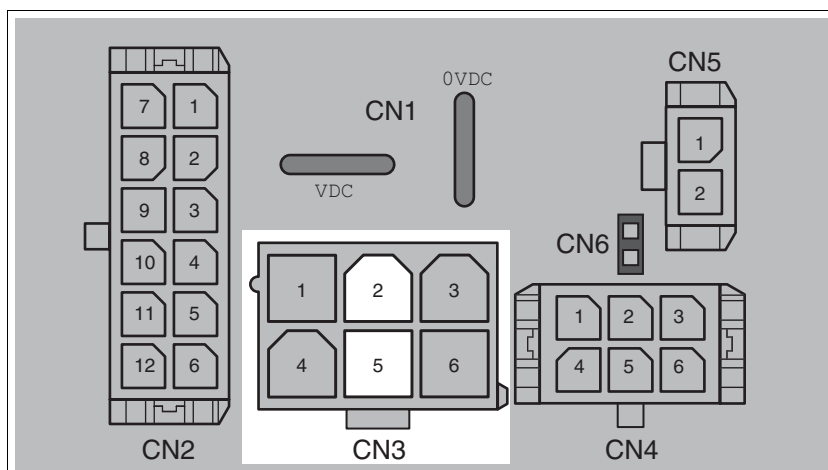

Figure 6.10 Pin assignment printed circuit board connector

Pin	Signal	Meaning
2	+RS485	RS485 interface
5	-RS485	RS485 interface

6.3.8 24V signal interface connection

Internal 24V signal power supply An internal 24V power supply for the sensor system is integrated in the product.

The internal 24V signal power supply must not be connected to the internal 24V signal power supply of another product.

Cable specifications and terminal

Minimum conductor cross section	[mm ²]	0.2 (AWG 24)
Maximum connection cross section	[mm ²]	0.6 (AWG 20)
Stripping length	[mm]	2.5 ... 3.0

- ▶ Use pre-assembled cables to reduce the risk of wiring errors.
- ▶ Verify that wiring, cables and connected interfaces meet the PELV requirements.

Configuration Different functions can be assigned to the digital signal inputs and outputs. For a detailed description, see chapter 8.6.9 "Configurable inputs and outputs".

Factory settings The following table provides an overview of the factory settings.

Pin	Signal	Factory setting	I/O
CN4.3	LIO1	Input Positive limit switch (LIMP)	I
CN4.6	LIO2	Input Negative limit switch (LIMN)	I
CN4.2	LIO3	Input Free available	I
CN4.5	LIO4	Input Reference switch (REF)	I

⚠ WARNING

LOSS OF CONTROL

The use of $\overline{\text{LIMP}}$ and $\overline{\text{LIMN}}$ can provide some protection against hazards (e.g. collision with mechanical stop caused by incorrect reference values).

- Use $\overline{\text{LIMP}}$ and $\overline{\text{LIMN}}$ where possible.
- Verify that the external sensors or switches are properly connected.
- Verify the correct of the limit switches. The limit switches must be mounted in a position far enough away from the mechanical stop to allow for an adequate stopping distance.
- Before you can use $\overline{\text{LIMP}}$ and $\overline{\text{LIMN}}$, you must enable them.

Failure to follow these instructions can result in death, serious injury or equipment damage.

During movements the two limit switches are monitored via the input signals $\overline{\text{LIMP}}$ and $\overline{\text{LIMN}}$. When a limit switch is reached, the drive stops. Triggering of the limit switch is signaled.

019844113652, V2.00, 11.2008

Pin assignment printed circuit board connector

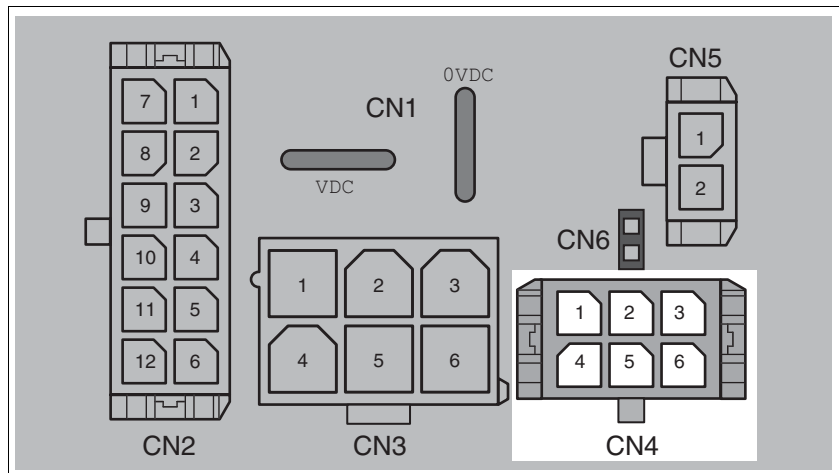

Figure 6.11 Pin assignment printed circuit board connector

Pin	Signal	Meaning	I/O
1	+24VDC_OUT	The internal 24V signal power supply may be used to supply the sensor system (for example, limit switches)	O
2	LIO3	Freely usable input / output	I/O
3	LIO1	Freely usable input / output	I/O
4	0VDC	Internally connected to CN1 . 0VDC	
5	LIO4	Freely usable input / output	I/O
6	LIO2	Freely usable input / output	I/O

6.3.9 Connection of STO safety function

⚠ WARNING
<p>LOSS OF SAFETY FUNCTION</p> <p>Incorrect usage may cause a hazard due to the loss of the safety function.</p> <ul style="list-style-type: none"> Observe the requirements for using the safety function. <p>Failure to follow these instructions can result in death or serious injury.</p>

Requirements

For information and requirements relating to the STO safety function, see page 48.

Cable specifications and terminal

- Shielded cable corresponding to the requirements for protected layout of wires

Minimum conductor cross section	[mm ²]	0.34 (AWG 20)
Maximum connection cross section	[mm ²]	0.6 (AWG 20)
Stripping length	[mm]	2.5 ... 3.0

- ▶ Use equipotential bonding conductors, see page 55.
- ▶ Use pre-assembled cables to reduce the risk of wiring errors.
- ▶ Verify that wiring, cables and connected interfaces meet the PELV requirements.

The cable available as an accessory is a special cable that is only available with a connector. The shield of the cable is connected to the grounded housing of the drive via the metal connector. It is sufficient to connect one end of the cable to the grounded housing.

019844113652, V2.00, 11.2008

Pin assignment printed circuit board connector

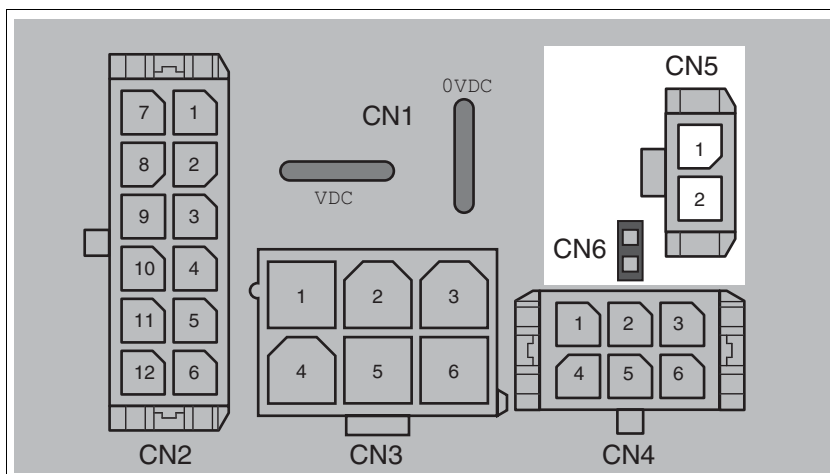
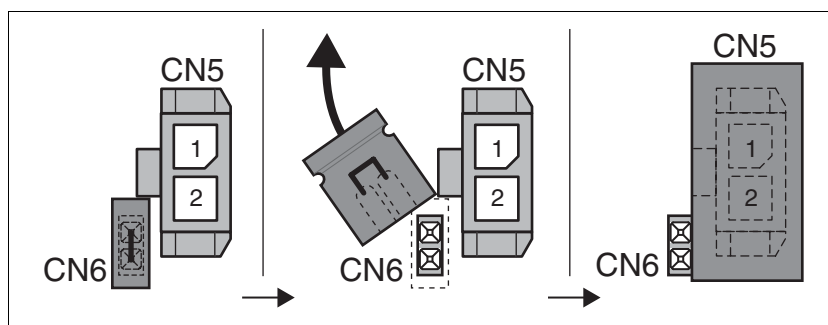

Figure 6.12 Pin assignment of safety function

Pin	Signal	Meaning
CN5.1	STO_A (PWRR_A)	Safety function STO "Safe Torque Off" (IEC/ EN 61800-5-2)
CN5.2	STO_B (PWRR_B)	Safety function STO "Safe Torque Off" (IEC/ EN 61800-5-2)
CN6		Jumper plugged in: STO disabled Jumper removed: STO enabled

NOTE: Jumper CN5 cannot be plugged in as long as jumper CN6 is still plugged in (mechanical lock).

Connecting the safety function



- ▶ Remove jumper CN6.
- ▶ Connect the connector to CN5.

6.4 Connection accessories

6.4.1 Accessory "Insert kit, 3x I/O"

The accessory makes the signals LIO1, LIO2 and LIO4 available outside of the device via industrial connectors.

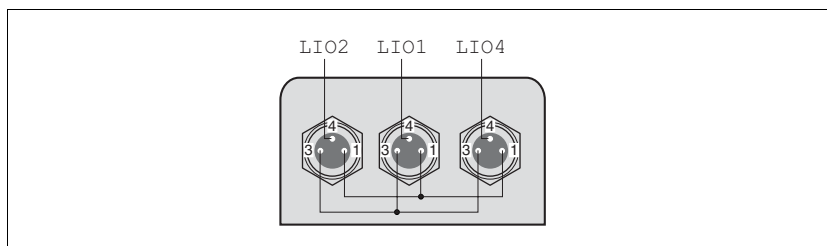

Figure 6.13 Pin assignment

Pin 1 is internally connected to CN4.1 (+24VDC_OUT).

Pin 3 is internally connected to CN4.4 (0VDC).

6.4.2 Accessory "Insert kit, 2x I/O, 1x STO in"

The accessory makes the signals LIO1, LIO2 and the signals of the STO safety function available outside of the device via industrial connectors.

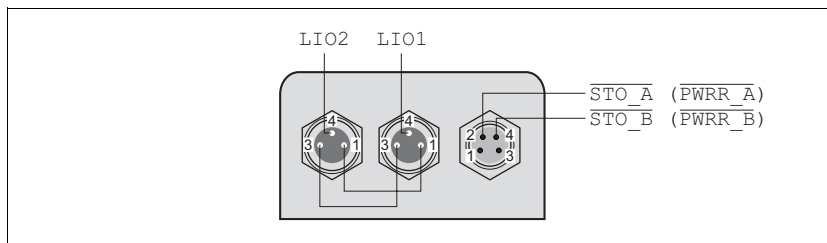

Figure 6.14 Pin assignment

Pin 1 is internally connected to CN4.1 (+24VDC_OUT).

Pin 3 is internally connected to CN4.4 (0VDC).

6.4.3 Accessory "Insert kit, 1x STO in, 1x STO out"

The accessory makes the signals of the STO safety function available outside of the device via industrial connectors.

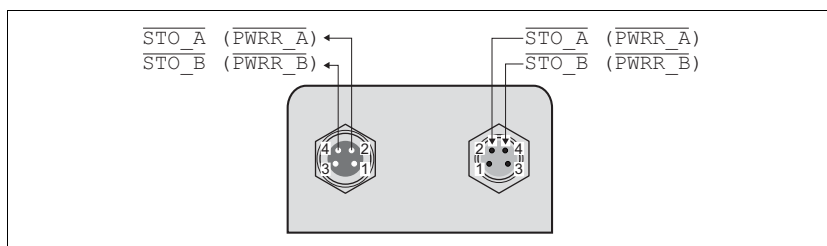

Figure 6.15 Pin assignment

019844113652, V2.00, 11.2008

6.4.4 Accessory "Insert kit, 4x I/O, 1x STO in, 1x STO out"

The accessory makes the signals LIO1, LIO2, LIO3 and LIO4 and the signals of the STO safety function available outside of the device via industrial connectors.

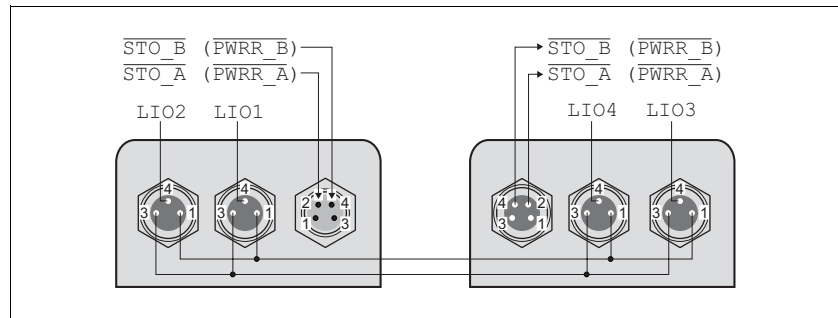

Figure 6.16 Pin assignment

Pin 1 is internally connected to CN4.1 (+24VDC_OUT).

Pin 3 is internally connected to CN4.4 (0VDC).

6.5 Checking wiring

Verify proper installation:

- ▶ Did you properly install and connect all cables and connectors?
- ▶ Are there any live, exposed cables?
- ▶ Did you properly connect the signal wires?
- ▶ Did you properly install all seals (degree of protection IP54)?

7 Commissioning



An alphabetically sorted overview of **all** parameters can be found in the chapter "Parameters". The use and the function of some parameters are explained in more detail in this chapter.

⚠ DANGER

UNINTENDED CONSEQUENCES OF EQUIPMENT OPERATION

When the system is started, the drives are usually out of the operator's view and cannot be visually monitored.

- Only start the system if there are no persons in the hazardous area.

Failure to follow these instructions will result in death or serious injury.

⚠ WARNING

UNEXPECTED MOVEMENT

When the drive is operated for the first time, there is a risk of unexpected movements caused by possible wiring errors or unsuitable parameters.

- Perform the first test run without coupled loads.
- Verify that a functioning button for EMERGENCY STOP is within reach.
- Anticipate movements in the incorrect direction or oscillation of the drive.
- Only start the system if there are no persons or obstructions in the hazardous area.

Failure to follow these instructions can result in death, serious injury or equipment damage.

▲ WARNING**UNINTENDED BEHAVIOR**

The behavior of the drive system is governed by numerous stored data or settings. Unsuitable settings or data may trigger unexpected movements or responses to signals and disable monitoring functions.

- Do NOT operate the drive system with unknown settings or data.
- Verify that the stored data and settings are correct.
- When commissioning, carefully run tests for all operating states and potential fault situations.
- Verify the functions after replacing the product and also after making changes to the settings or data.
- Only start the system if there are no persons or obstructions in the hazardous area.

Failure to follow these instructions can result in death, serious injury or equipment damage.

▲ WARNING**MOTOR WITHOUT BRAKING EFFECT**

If power outage and faults cause the power stage to be switched off, the motor is no longer stopped by the brake and may increase its speed even more until it reaches a mechanical stop.

- Verify the mechanical situation.
- If necessary, use a cushioned mechanical stop or a suitable brake.

Failure to follow these instructions can result in death, serious injury or equipment damage.

▲ WARNING**ROTATING PARTS**

Rotating parts may cause injuries and may catch clothing or hair. Loose parts or parts that are unbalanced may be flung.

- Verify correct mounting and installation of all rotating parts.
- Use a cover to help protect against rotating parts.

Failure to follow these instructions can result in death, serious injury or equipment damage.

▲ WARNING**FALLING PARTS**

The motor may move, tip and crash down as a result of the reaction torque.

- Mount the motor securely so it will not break loose during strong acceleration.

Failure to follow these instructions can result in death, serious injury or equipment damage.

▲ CAUTION**HOT SURFACES**

Depending on the operation, the surface may heat up to more than 100°C (212°F).

- Do not allow contact with the hot surfaces.
- Do not allow flammable or heat-sensitive parts in the immediate vicinity.
- Consider the measures for heat dissipation described.
- Check the temperature during test runs.

Failure to follow these instructions can result in injury or equipment damage.

7.1 Overview

This chapter describes the commissioning procedure for the drive.

Required components

The following components are required for commissioning:

- Commissioning software Lexium CT
<http://www.schneider-electric.com>



The following commissioning steps are also required if you want to use a configured device under changed operating conditions.

To be done

- ▶ Carry out the steps below in the specified order.

To be done ...	Page
6.5 "Checking wiring"	76
7.2.1 "Possibilities of setting the IP address"	81
7.2.2 "Setting the IP address"	82
7.2.3 "Adding the device to the fieldbus"	85
7.2.4 "Lexium CT commissioning software"	86

- ▶ Carry out the following steps using the commissioning software.

To be done ...	Page
7.2.7 "Setting basic parameters and limit values"	93
7.2.8 "Digital inputs / outputs"	96
7.2.9 "Checking the signals of the limit switches"	97
7.2.10 "Testing safety function STO"	98
7.2.11 "Releasing the holding brake manually"	99
7.2.12 "Checking direction of rotation"	100
7.2.13 "Setting parameters for encoder"	101

7.2 Commissioning procedure

⚠ WARNING
<p>LOSS OF CONTROL DUE TO UNSUITABLE PARAMETER VALUES</p> <p>Unsuitable parameter values may disable monitoring functions and trigger unexpected movements or responses of signals.</p> <ul style="list-style-type: none"> • Prepare a list with the parameters required for the functions used. • Check the parameters before operation. • Only start the system if there are no persons or obstructions in the hazardous area. <p>Failure to follow these instructions can result in death, serious injury or equipment damage.</p>

7.2.1 Possibilities of setting the IP address

There are 4 ways of configuring the IP address when the product boots:

- DHCP address assignment by means of a "DeviceName", page 83
- DHCP address assignment via the MAC address, page 83
- Using the IP address from the EEPROM, page 84
- Deriving the IP address from the MAC address, page 84

7.2.1.1 Saving the configuration

The product provides 3 parameters for saving the configuration:

Parameter	Size	Description
IPAddr	UINT 32	IP address of the device
SubMask	UINT 32	Subnet mask of the device
Gateway	UINT 32	Network gateway

7.2.1.2 Interfaces for entering the IP address

There are two interfaces for specifying the way the IP address for the product is set via Modbus.

- For a basic configuration without software, the device provides 2 rotary switches.
- The commissioning software or the Web server (see page 88) must be used for an extended configuration. The device must have a valid IP address for access via these interfaces!

Device status

The connection status is indicated by the green LED on the Ethernet option board, see chapter 10.2.3 "Error and status indication via LEDs". The device status is checked cyclically.

019844113652, V2.00, 11.2008

7.2.2 Setting the IP address

7.2.2.1 Rotary switches for setting the IP address

The two rotary switches for setting the IP address have the following positions and functions:

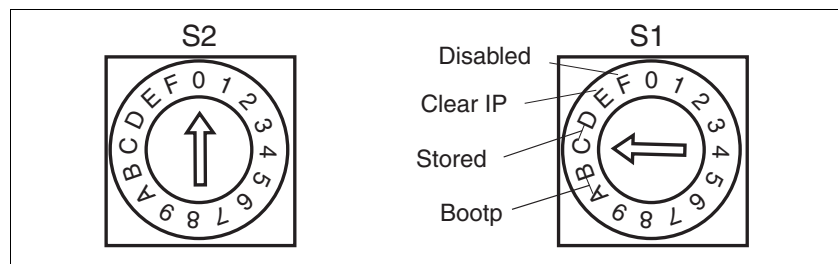

Figure 7.1 Settings of the rotary switches

ID	Name of switch function	Function	Valid positions (S2)	Valid positions (S1)
1	Device Name	DHCP server required; the IP address is assigned via the DeviceName.	0 - F	0 - 9
2	BootP	DHCP or Bootstrap Protocol server required; the IP address is assigned via the MAC address.	Any	A, B
3	Stored	Uses the IP parameters stored in the EEPROM	Any	C, D
4	Clear IP	Deletes the IP parameters stored in the EEPROM.	Any	E
5	Disabled	Disables the rotary switch settings.	Any	F

7.2.2.2 Initial commissioning: IP address from the EEPROM

For commissioning several devices, you must first set a separate IP address for each device. This can only be done by means of the rotary switches as described on page 83. Only after that, a new device can be added to the network.



The product ships with the IP address 192.168.100.10.

You can connect to the product with a PC and configure it. The PC must be set to an IP address 192.168.100.x with x being any value between 1 and 254 except for 10. Contact your network administrator if you have questions concerning details.

See also chapter 7.2.2.6 "Using the IP address from the EEPROM".

7.2.2.3 Setting the IP address via the rotary switches

A new IP address is created in the following way: The first 3 bytes are taken from the EEPROM. The default setting for these 3 bytes is 192.168.100. It is also possible that a user-defined IP address was stored in the EEPROM. The last byte is set with the rotary switches. Procedure:

- ▶ Switch off the device.
- ▶ Set the rotary switch "S1" to "Clear IP".
- ▶ Wait until the status LED indicates "No valid IP parameters after a Clear IP" (2x flash).
- ▶ The set the last byte of the IP address by means of the two rotary switches.

The number is the result of $10 * S2 + S1$. A 0 must not be assigned. The device only accepts values from 1 to 159.

- ▶ After having set the desired IP address, wait until the status LED indicates "Ready without error" (Steady ON).

If, after that, you change the settings of the rotary switches to select a different IP address, the status LED indicates "No valid IP parameters after a Clear IP" (2x flash) again.

- ▶ To take over the IP address, the device must be switched off when the status LED indicates "Ready without error" (Steady ON).
- ▶ After having switched off the device, set rotary switch S1 auf "Stored". Rotary switch S2 can be set to any position.
- ▶ Switch on the device. The new IP address is now valid.

7.2.2.4 DHCP address assignment via the DeviceName

To assign the IP address via the DeviceName, a DHCP server must be available on the network.

The DeviceName can only be set using the two rotary switches see page 83. Eine Konfiguration über Softwareparameter ist nicht möglich.

The DeviceName is the string "Lexium-ILx-" and a three-digit number. This number results from the setting of the two rotary switches:

DeviceName = "Lexium-ILx-" + ASCII ($10 * S2 + S1$)

This procedure is used for Faulty Device Replacement, see page 43. After a failure, the DeviceName for the new device is set to the same name as that of the defective device. This way, the new device is assigned the same IP and the same configuration as the defective device.

7.2.2.5 DHCP address assignment via the MAC address

To assign the IP address via the MAC address, a DHCP/BOOTP server must be available on the network. The MAC address is shown on the drive next to the connectors.

This option is set via the rotary switches, see page 83. Rotary switch S1 must be set to "Bootp". The position of rotary switch S2 is not evaluated. It is not possible to set this configuration via a software tool.

The DHCP/BOOTP server must manage a list that links each MAC address with an IP address so each device has a different IP address.

7.2.2.6 Using the IP address from the EEPROM

In this case, the IP configuration is loaded from the EEPROM. Rotary switch S1 must be set to "Stored", see page 83. The position of rotary switch S2 is not evaluated.

The commissioning software or the integrated Web server allows you to change the IP configuration. After a re-start of the device, the new IP configuration is used.

7.2.2.7 Deriving the IP address from the MAC address



With this setting, the same IP address may be assigned to different devices.

This option is set via the rotary switches, see page 83. Rotary switch S1 must be set to Disabled. The position of rotary switch S2 is not evaluated. It is not possible to set this configuration via a software tool.

The IP configuration results from default settings and the MAC address. The MAC address is shown on the drive next to the connectors.

IPAddr	=	192.168.100.xxx
SubMask	=	255.255.255.0
Gateway	=	IPAddr

The last part of the IP address results from the last byte of the MAC address.

Example 1 If the device has the MAC address xx:xx:xx:xx:xx:06, the resulting IP address is 192.168.100.6.

Example 2 If the device has the MAC address xx:xx:xx:xx:xx:A7, the resulting IP address is 192.168.100.167.

Exceptions The last part of the MAC address has the value range from 00 to FF (0 to 255). With the preset subnet mask, 0 is the network address and 255 the broadcast address. This means that these two addresses cannot be used. This results in the following exception handling:

- If the last byte of the MAC address is 00, the IP address assigned is 192.168.100.1.
- If the last byte of the MAC address is FF (255), the IP address assigned is 192.168.100.254.

7.2.2.8 Double IP address

Each device on the network must have a unique IP address. If an IP address is assigned more than once, this error is indicated by the flashing status LED (4 times per cycle) after the device is switched on. Please note that the LEDs may be hard to see after the devices are installed.

For additional information on the LEDs, see Diagnostics, chapter 10.2.2 "LED signal codes".

7.2.3 Adding the device to the fieldbus

See the appropriate manual for adding the device to the field bus, for example, via a Premium controller.

7.2.4 Lexium CT commissioning software

The commissioning software has a graphic user interface and is used for commissioning, diagnostics and testing settings.

Source commissioning software The latest version of the commissioning software is available for download from the internet:

<http://www.schneider-electric.com>

Functions of the commissioning software The functions of the commissioning software include:

- Scan various fieldbuses for devices
- Extensive information on connected devices
- Display and enter device parameters
- Archive and duplicate device parameters
- Manual positioning of the motor
- Test input and output signals
- Record, evaluate and archive motion and signals
- Error diagnostics
- Optimize control behavior (servo motors only)

System requirements The minimum hardware requirements for installation and operation of the software are:

- IBM-compatible PC
- Approx. 200 MB of hard disk space
- 512 MB RAM
- Graphics card and monitor with a resolution of at least 1024x768 pixels
- Free serial interface (RS232) or free USB interface
- Operating system Windows 2000, Windows XP Professional or Windows Vista
- Acrobat Reader 5.0 or newer
- Internet connection (for initial installation and updates)

Online help The commissioning software offers comprehensive help functions, which can be accessed via "? - Help Topics" or by pressing the F1 key.

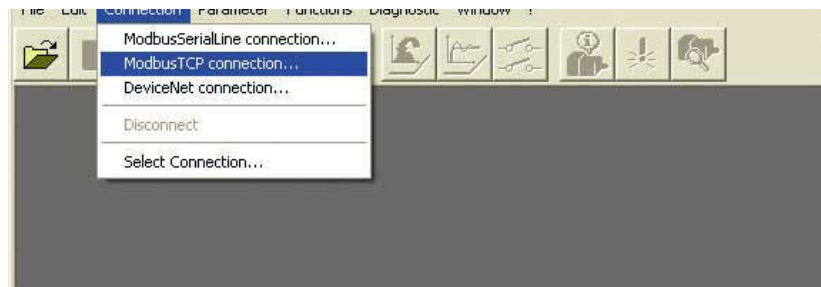

Figure 7.2 Lexium CT, Selecting a Modbus TCP connection

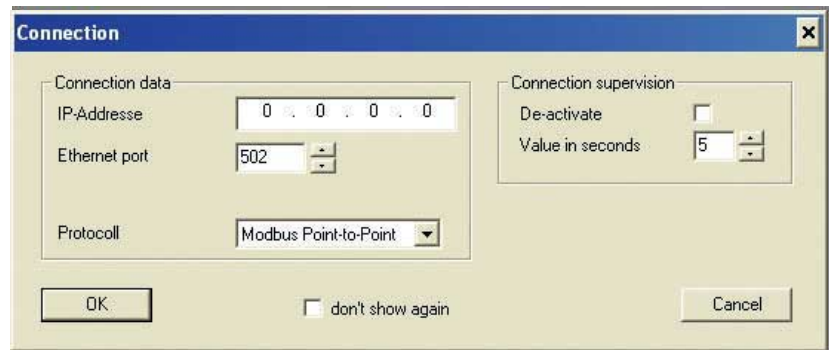

Figure 7.3 Lexium CT, entering the connection data

- ▶ Enter the IP address of the product in the field **IP Address**.
- ▶ Enter the value **502** in the field **Ethernet Port**.

7.2.5 Web server

The product features an integrated Web server. This allows the product to be configured without the commissioning software.

Connecting

- The product must have a valid IP address.
- ▶ Start an Internet browser.
- ▶ Enter the IP address of the product in the address bar.

Password-protected access

- ▶ Connect as described above.
- ▶ Click the **Maintenance** tab and then the appropriate submenu.
- ▶ Enter the following in the fields (uppercase): **Username** -> "USER" and **Password** -> "USER".

After authentication, the system displays the main page. Access to the main page is blocked after three unsuccessful attempts.

Parameters are entered in a way similar to Lexium CT.

- ▶ Click the **Write** button to send the parameters to the drive.
- ▶ After that, click the **Save** button to save the parameters to the non-volatile memory of the drive.

A warning is displayed if you have not yet saved the values.

User interface The user interface of the Web server is structured as shown on the screenshot below:



Figure 7.4 User interface

- (1) Main menu
- (2) Submenu
- (3) Content

Web server functions General access:

- Diagnostics
- Display the manual

Password-protected access:

- Display parameters
- Change parameters

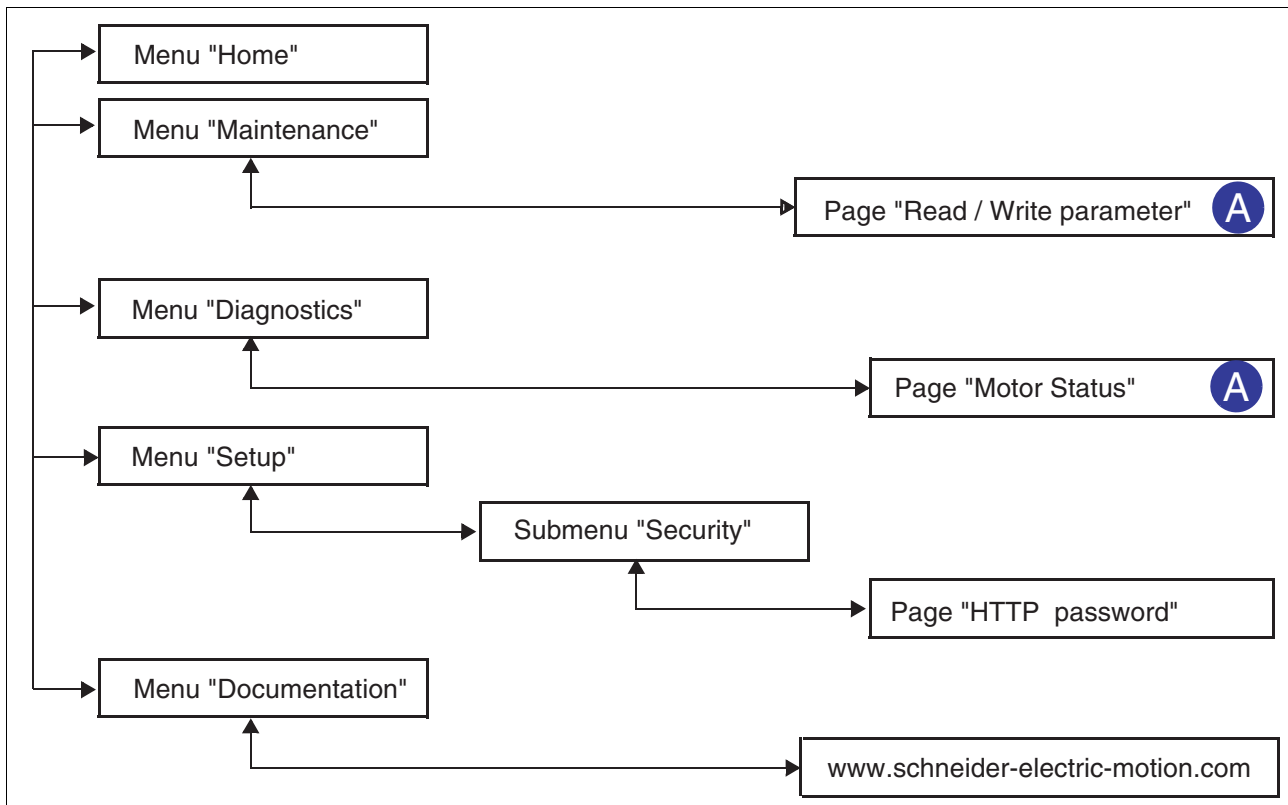

Figure 7.5 Web server page structure

Menu	Page	Function
HOME	English	Homepage
MAINTENANCE	Read / write parameters	Edit motor and communication parameters
DIAGNOSTICS	Ethernet Statistics	View communication statistics Product identification
SETUP	[Security] HTTP password	Change the password for access to the Web server (HTTP password). The HTTP cannot be reset to the website, but only via the menu item Restore Factory Defaults
DOCUMENTATION	References	Link to the website http://www.schneider-electric-motion.com

7.2.6 Connection monitoring

⚠ WARNING

LOSS OF CONTROL

- Activate the time-out function. Without time-out, the system will not detect the interruption of the communication link.
- The shorter the time-out period the faster the detection of the interruption.

Failure to follow these instructions can result in death, serious injury or equipment damage.

Two monitoring mechanisms are used on an ongoing basis on the master and slave sides to monitor the exchange of data for errors:

- Monitoring for interruption of the Ethernet connection
- Timeout monitoring

Monitoring for interruption of the Ethernet connection

The drive can detect a loss of the Ethernet communication link only if the interruption is directly at the drive, i.e. if there is no Ethernet switch in between.

Timeout monitoring for I/O Scanning

The time interval for I/O Scanning can be set via the parameter MBscan_guard. Monitoring starts when the device receives the first I/O message.

Parameter Name	Description	Unit Minimum value Default value Maximum value	Data type R/W persistent Expert	Parameter address via fieldbus
MBscan_guard	ModbusTCP node guard for I/O scanning 0: Inactive (default) >0: Monitoring time in ms The drive starts monitoring when it receives the first I/O scanning message. After a node guarding error the drive starts monitoring again when it receives the next I/O scanning message.	ms 0 0 10000	UINT16 R/W - -	Modbus 6414

Timeout monitoring for individual Modbus TCP channels

In order to monitor an individual Modbus TCP channel, the parameter MBnode_guard must be set via this channel. The device then checks whether communication is still active via this channel.

If the device no longer receives Modbus messages via this channel, the current processing is stopped with an error of error class 2.

Parameter Name	Description	Unit Minimum value Default value Maximum value	Data type R/W persistent Expert	Parameter address via fieldbus
MBnode_guard	Modbus node guard Node guard 0: Inactive (default) >0: Monitoring time	ms 0 0 10000	UINT16 R/W - -	Modbus 5644

019844113652, V2.00, 11.2008

Using timeout monitoring If timeout monitoring is not used, an interruption of the communication link does not generate an error message. The controller keeps executing the most recently transmitted command.

Use the timeout function during normal operation on the network. Timeout monitoring can be switched off during troubleshooting. The system integrator must then provide alternative control paths for stopping and controlling the motor.

7.2.7 Setting basic parameters and limit values

⚠ WARNING

UNINTENDED BEHAVIOR

The behavior of the drive system is governed by numerous stored data or settings. Unsuitable settings or data may trigger unexpected movements or responses to signals and disable monitoring functions.

- Do NOT operate the drive system with unknown settings or data.
- Verify that the stored data and settings are correct.
- When commissioning, carefully run tests for all operating states and potential fault situations.
- Verify the functions after replacing the product and also after making changes to the settings or data.
- Only start the system if there are no persons or obstructions in the hazardous area.

Failure to follow these instructions can result in death, serious injury or equipment damage.



Prepare a list with the parameters required for the functions used.

Setting thresholds

Suitable thresholds must be calculated from the system configuration and motor characteristics. So long as the motor is operated without external loads you will not need to change the default settings.

The maximum motor current must for example be reduced as a determining factor of the torque if the permissible torque of a system component will otherwise be exceeded.

Current limitation

The maximum motor current can be set with the parameter CTRL_I_max.

The maximum current for the "Quick Stop" function can be limited with the parameter LIM_I_maxQSTP and for the "Halt" function with the parameter LIM_I_maxHalt.

- ▶ Use the parameter CTRL_I_max to set the maximum motor current.
- ▶ Use the parameter LIM_I_maxQSTP to set the maximum motor current for the "Quick Stop" function.
- ▶ Use the parameter LIM_I_maxHalt to set the maximum motor current for the "Halt" function.

In operating modes with profile generator, acceleration and deceleration are limited through ramp functions. The motor can be decelerated via a deceleration ramp or the maximum current for the functions "Quick Stop" and "Halt".

Parameter Name	Description	Unit Minimum value Default value Maximum value	Data type R/W persistent Expert	Parameter address via fieldbus
CTRL_I_max	Current limitation The value must not exceed the maximum permissible current of the motor or the power stage. Default: M_I_max	A _{pk} 0.00 - 299.99	UINT16 R/W per. -	Modbus 4610
LIM_I_maxQSTP	Current limitation for Quick Stop Max. current during braking via torque ramp due to an error of error classes 1 or 2 and when a software stop is triggered. Maximum and default settings depend on the motor and the power stage (settings M_I_max and PA_I_max) In increments of 0.01A _{pk}	A _{pk} - - -	UINT16 R/W per. -	Modbus 4362
LIM_I_maxHalt	Current limitation for Halt Max. current during braking after Halt or when an operating mode is terminated. Maximum and default settings depend on the motor and the power stage (settings M_I_max and PA_I_max) In increments of 0.01A _{pk}	A _{pk} - - -	UINT16 R/W per. -	Modbus 4364

Limitation of speed of rotation The parameter CTRL_n_max can be used to limit the maximum speed of rotation.

- Use the parameter CTRL_n_max to set the maximum speed of rotation of the motor.

Parameter Name	Description	Unit Minimum value Default value Maximum value	Data type R/W persistent Expert	Parameter address via fieldbus
CTRL_n_max	Speed limitation The set value must not exceed the maximum motor speed. Default: maximum motor speed (see M_n_max)	min ⁻¹ 0 - 13200	UINT16 R/W per. -	Modbus 4612

Limitation of reference speed of rotation For operating modes that are executed with the profile generator (ramps), the reference speed can be limited with the parameter RAMPn_max.

- Use the parameter RAMPn_max to set the maximum reference speed of rotation.

Parameter Name HMI menu	Description	Unit Minimum value Default value Maximum value	Data type R/W persistent Expert	Parameter address via fieldbus
RAMPn_max	<p>Limitation of ref. speed for op. modes with profile generation</p> <p>The parameter is active in the following operating modes:</p> <ul style="list-style-type: none"> - Profile position - Profile velocity - Homing - Jog <p>If a greater reference speed is set in one of these operating modes, it is automatically limited to RAMPn_max. This way, commissioning at limited speed is easy to perform.</p>	<p>min⁻¹</p> <p>60</p> <p>13200</p> <p>13200</p>	<p>UINT16</p> <p>R/W</p> <p>per.</p> <p>-</p>	Modbus 1554

7.2.8 Digital inputs / outputs

The device has 4 configurable 24V signals. These 24V signals can each be configured as either an input or an output.

The configuration of the 24V signals is described in chapter 8.6.9 "Configurable inputs and outputs".

Factory settings The following table provides an overview of the factory settings.

Pin	Signal	Factory setting	I/O
CN4.3	LIO1	Input Positive limit switch (LIMP)	I
CN4.6	LIO2	Input Negative limit switch (LIMN)	I
CN4.2	LIO3	Input Free available	I
CN4.5	LIO4	Input Reference switch (REF)	I

Signal level The `_IO_LIO_act` parameter provides information on the current signal level of the 24V signals.

Parameter Name	Description	Unit	Data type	Parameter address via fieldbus
		Minimum value	R/W	
		Default value	persistent	
		Maximum value	Expert	
<code>_IO_LIO_act</code>	Status of digital inputs/outputs	-	UINT16	Modbus 2090
	Coding of the individual signals:	-	R/-	
	Bit 0: LIO1	0	-	
	Bit 1: LIO2	-	-	
	...			

7.2.9 Checking the signals of the limit switches

⚠ WARNING**LOSS OF CONTROL**

The use of $\overline{\text{LIMP}}$ and $\overline{\text{LIMN}}$ can provide some protection against hazards (e.g. collision with mechanical stop caused by incorrect reference values).

- Use $\overline{\text{LIMP}}$ and $\overline{\text{LIMN}}$ where possible.
- Verify that the external sensors or switches are properly connected.
- Verify the correct of the limit switches. The limit switches must be mounted in a position far enough away from the mechanical stop to allow for an adequate stopping distance.
- Before you can use $\overline{\text{LIMP}}$ and $\overline{\text{LIMN}}$, you must enable them.

Failure to follow these instructions can result in death, serious injury or equipment damage.

- You must have configured the functions "Negative limit switch (LIMN)" and "Positive limit switch (LIMP)", see chapter 8.6.9 "Configurable inputs and outputs".
- ▶ Set up the limit switches in such a way as to keep the drive from overtraveling the limit switches.
- ▶ Trigger the limit switches manually.
- ◁ The commissioning software displays an error condition caused by a limit switch.

The appropriate parameters can be used to release the limit switches and to set the evaluation to active 0 or active 1, see chapter 8.6.1 "Monitoring functions".



Use active 0 monitoring signals if possible, because they are failsafe.

7.2.10 Testing safety function STO

Operation with STO If you wish to use the STO safety function, carry out the following steps.

- Supply voltage switched off.
- ▶ Verify that the inputs $\overline{STO_A}$ ($\overline{PWRR_A}$) and $\overline{STO_B}$ ($\overline{PWRR_B}$) are electrically isolated from each other. The two signals must not be electrically connected.
- Supply voltage switched on.
- ▶ Enable the power stage (without motor movement).
- ▶ Trigger the safety function. $\overline{STO_A}$ ($\overline{PWRR_A}$) and $\overline{STO_B}$ ($\overline{PWRR_B}$) must be switched off simultaneously (time offset <1s).
- ◁ The power stage is disabled and error message 1300 is generated. (NOTE: Error message 1301 indicates a wiring error.)
- ▶ Verify that the `IO_AutoEnable` parameter is set to "off" to avoid unexpected restart.
- ▶ Check the behavior of the drive during fault conditions.
- ▶ Document all tests of the safety function in your acceptance certificate.

Operation without STO You must perform the following steps if you do not want to use the STO safety function.

- ▶ Check whether the jumper CN6 is connected.

7.2.11 Releasing the holding brake manually

The drive automatically controls the integrated holding brake. However, during commissioning it may be necessary to release the holding brake manually.

The power supply must be on to release the holding brake manually.

⚠ WARNING
UNEXPECTED MOVEMENT
Manual release of the holding brake or an error may cause an unexpected movement in the system.
<ul style="list-style-type: none"> • Switch off the voltage at the inputs $\overline{STO_A}$ ($\overline{PWRR_A}$) and $\overline{STO_B}$ ($\overline{PWRR_B}$) to avoid an unexpected restart of the motor. • Take appropriate measures to avoid damage caused by the falling loads. • Only run the test if there are no persons or obstacles in the hazardous area.
Failure to follow these instructions can result in death or serious injury.

Power stage disabled The holding brake can be released with the parameter BRK_release and the commissioning software when the power stage is not enabled. The power stage cannot be enabled with a manually released holding brake.

Power stage enabled When the power stage is enabled, the automatic holding brake controller is active. If the holding brake is manually released an error message is generated.

Parameter Name	Description	Unit	Data type	Parameter address via fieldbus
BRK_release	Processing of holding brake	-	UINT16	Modbus 2068
	0 / close: automatic processing (default)	0	R/W	
	1 / open: manual release of brake	0 1	- -	
	The brake output can only be activated in the states 'Switch on disabled' or 'Ready to switch on'.			
	If the power stage is active, the value is automatically set to 0.			

019844113652, V2.00, 11.2008

7.2.12 Checking direction of rotation

Direction of rotation Rotation of the motor shaft in a clockwise or counterclockwise direction of rotation. Clockwise rotation is when the motor shaft rotates clockwise as you look at the end of the protruding motor shaft.

Use the commissioning software for the following activities.

- ▶ Start the operating mode Jog.
- ▶ Start a movement with clockwise direction of rotation.
- ◁ The motor rotates with clockwise direction of rotation.
- ▶ Start a movement with counterclockwise direction of rotation.
- ◁ The motor rotates with counterclockwise direction of rotation.
- ▶ If the arrow and direction of rotation do not match, correct this with the `POSdirOfRotat` parameter, see chapter 8.6.10 "Reversal of direction of rotation".

7.2.13 Setting parameters for encoder



This commissioning step is only required if you use an absolute encoder.

Setting an absolute position

When starting up, the device reads the absolute position of the motor from the encoder. The current absolute position can be read with the parameter `_p_absENCusr`.

When the motor is at a standstill, the current mechanical motor position can be defined as the new absolute position of the motor with the parameter `ENC_pabsusr`. The value can be set with the power stage enabled or disabled. Setting the absolute position also shifts the position of the index pulse of the encoder and the index pulse of the encoder simulation.

Parameter Name	Description	Unit	Data type	Parameter address via fieldbus
<code>_p_absENCusr</code>	Motor position with reference to encoder range in user units The value range is determined by the encoder type. In the case of singleturn encoders, the value refers to one motor revolution, in the case of multiturn encoders to the entire encoder range (e.g. 4096 revolutions). NOTE: The position is not valid until the absolute motor position has been determined. In the case of invalid absolute motor position: _WarnLatched _WarnActive Bit 13=1: Absolute motor position not yet captured	usr - 0 -	UINT32 R/ persistent Expert	Modbus 7710

Parameter Name	Description	Unit Minimum value Default value Maximum value	Data type R/W persistent Expert	Parameter address via fieldbus
ENC_pabsusr	<p>Directly set the motor encoder position</p> <p>The value range depends on the encoder type.</p> <p>Singleturn encoder: 0 ... max_pos_usr/rev. - 1</p> <p>Multiturn encoder: 0 ... (4096 * max_pos_usr/rev.) - 1</p> <p>max_pos_usr/rev.: maximum user position for one motor turn. This value is 16384 with the default scaling.</p> <p>NOTE:</p> <ul style="list-style-type: none"> * If processing is to be performed with inversion of the direction of rotation, this must be set before the motor encoder position is adjusted. * The set value does not become active until the controller is switched on the next time. After the write access, a wait time of at least 1 second is required before the controller is switched off. * Changing this value also changes the position of the virtual index pulse and the index pulse for the ESIM function. 	usr -2147483648 - 2147483647	INT32 R/W - -	Modbus 1324

Singleturn encoder In the case of a singleturn encoder, you can shift the position of the index pulse of the encoder by setting a new absolute position. If the position value is 0, the index pulse is defined at the current mechanical motor position.

This also changes the position of the index pulse of the encoder simulation.

Multiturn encoder In the case of a multiturn encoder, the mechanical working range of the motor can be shifted to the continuous range of the encoder by setting a new absolute position.

If the motor is moved counterclockwise from the absolute position 0, there is an underrun of the absolute position of the multiturn encoder. However, the internal actual position keeps counting forward and delivers a negative position value. After switching off and on, the internal actual position would no longer be the negative position value, but the absolute position of the encoder.

Overruns or underruns are discontinuous positions in the working range. To avoid such jumps, the absolute position in the encoder must be set in such a way that the mechanical limits are within the continuous range of the encoder.

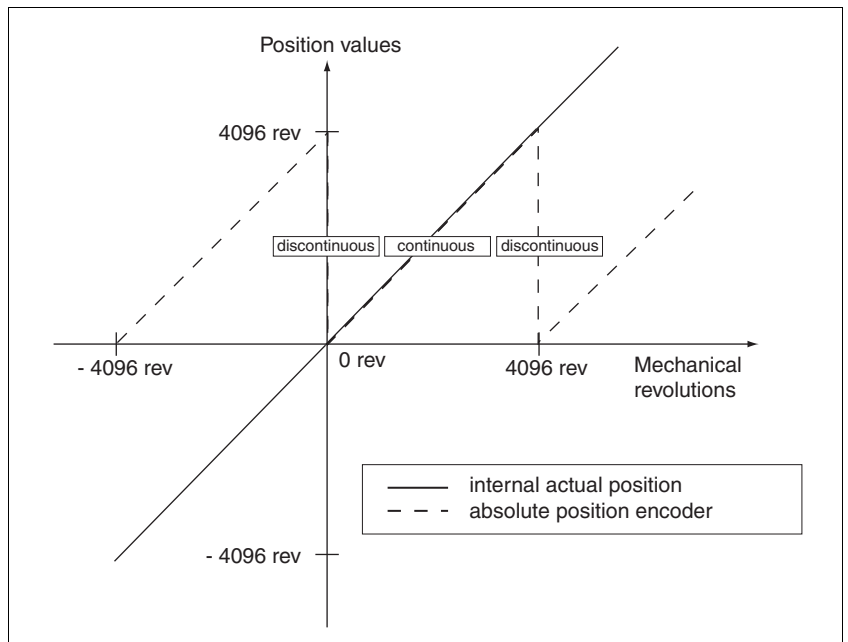

Figure 7.6 Position values of multiturn encoder

- Set the absolute position at the mechanical limit to a position value >0.

This achieves that the mechanical working range will be in the continuous range of the encoder.

7.3 Controller optimization with step response

7.3.1 Controller structure

The controller structure corresponds to the classical cascade control of a closed positioning loop with current controller, speed controller and position controller. The reference value of the speed controller can also be smoothed by an upstream filter.

The controllers are tuned from the "inside" to the "outside" in the following sequence: current controller, speed controller and position controller. The superimposed control loop remains off.

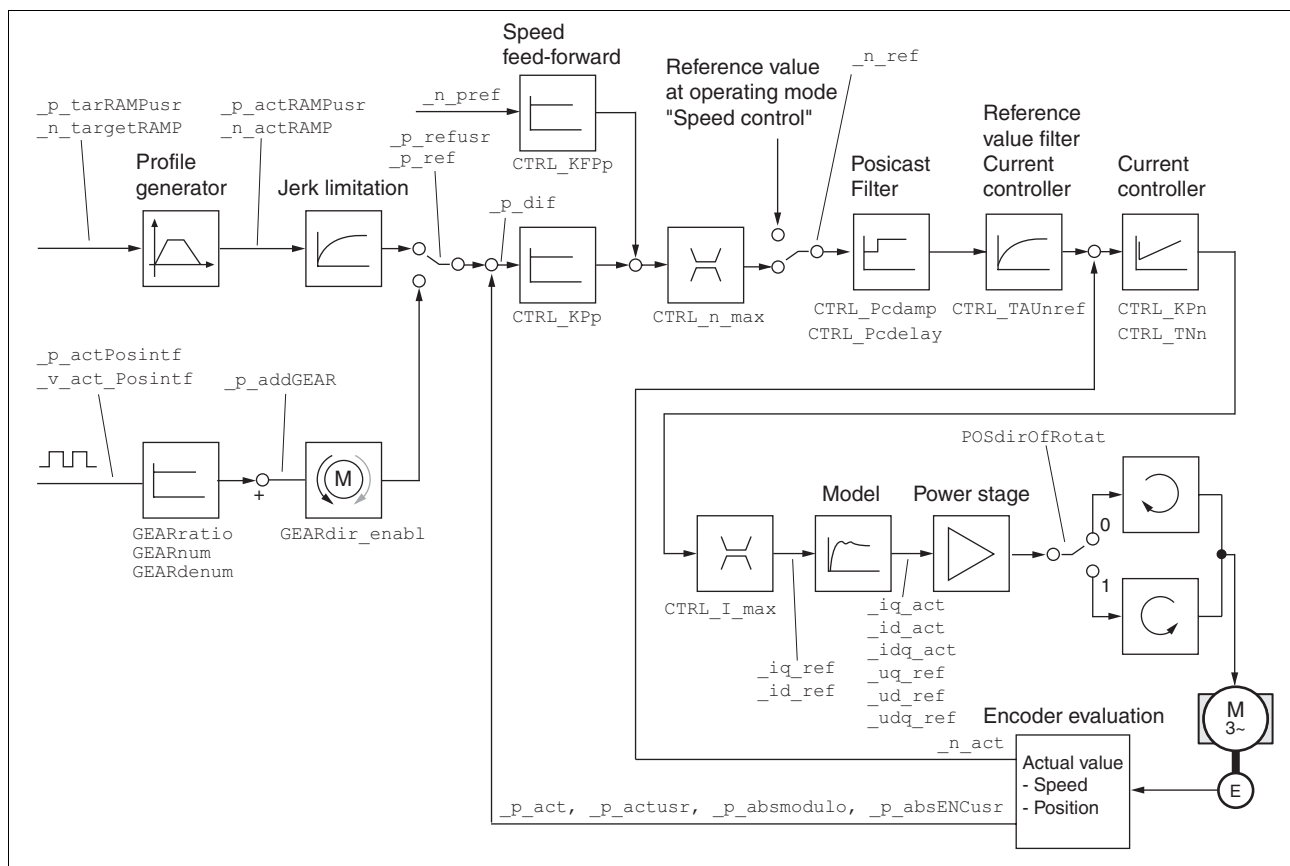

Figure 7.7 Controller structure

Current controller

The current controller determines the torque of the motor. The current controller is automatically optimally tuned with the stored motor data.

Speed controller

The speed controller maintains the required speed of rotation of the motor by varying the output motor torque depending on the load situation. The speed controller has a decisive influence on the speed with which the drive responds. The dynamics of the speed controller depend on:

- the moment of inertia of the drive and the controlled system
- the torque of the motor
- the stiffness and elasticity of the elements in the flow of forces
- the play of the mechanical drive elements
- the friction

Position controller The position controller reduces the difference between reference position and the actual position of the motor (position deviation) to a minimum. When the motor is at a standstill, the position deviation is close to zero in the case of a well-tuned position controller. When the motor is running, a position deviation results that depends on the speed of rotation.

In the operating modes Profile Position, Profile Velocity, Homing and Jog, the reference position for the closed positioning loop is generated by the internal motion profile generator.

An optimized speed control loop is a prerequisite for good amplification of the position controller.

7.3.2 Optimization

The drive optimization function matches the unit to the operating conditions. The following options are available:

- Selecting control loops. Higher level control loops are automatically disconnected.
- Defining reference signal: signal form, height, frequency and starting point
- Testing control response with the signal generator.
- Recording and assessing the control behavior on the monitor with the commissioning software.

Setting reference signals

- ▶ Start controller optimization with the commissioning software using the sequence of menus and commands "Functions - Recording/Tuning...".
- ▶ Display the "Tune" tab.
- ▶ Set the following values for the reference signal:
 - Amplitude: 100 rpm 1/min
 - Period: 100 ms
 - Signal: Positive step
 - Number of repetitions: 1
- ▶ Also note additional settings in the "Display - Specific Displays" menu.



Only the signal types "Step" and "Square" allow you to determine the entire dynamic behavior of a control loop. The manual shows all signal paths for the signal type "Step".

Entering controller values

The optimization steps described on the following pages require you to enter control loop parameters and test their effect by triggering a step function.

A step function is triggered as soon as you start recording in the commissioning software bar with the "Start" button (arrow icon).

You can enter controller values for optimization in the parameters window in the "Control" group.

7.3.3 Optimizing the speed controller

Optimum settings of complex mechanical control systems requires hands-on experience with controller tuning. This includes the ability to calculate control loop parameters and to apply identification procedures.

Less complex mechanical systems can often be successfully optimized by means of experimental adjustment using the aperiodic limit method. The following two parameters are used for this:

Parameter Name	Description	Unit Minimum value Default value Maximum value	Data type R/W persistent Expert	Parameter address via fieldbus
CTRL_KPn	Speed controller P-term The default value is calculated on the basis of the motor parameters.	A/min ⁻¹ 0.0001 - 1.2700	UINT16 R/W per. -	Modbus 4614
CTRL_TNn	Speed controller setting time	ms 0.00 - 327.67	UINT16 R/W per. -	Modbus 4616

Check and optimize the calculated values in a second step, as described on page 110.

Determining the mechanical system of the system

To assess and optimize the transient response behavior of your system, group its mechanical system into one of the following two categories.

- System with rigid mechanical system
- System with a less rigid mechanical system

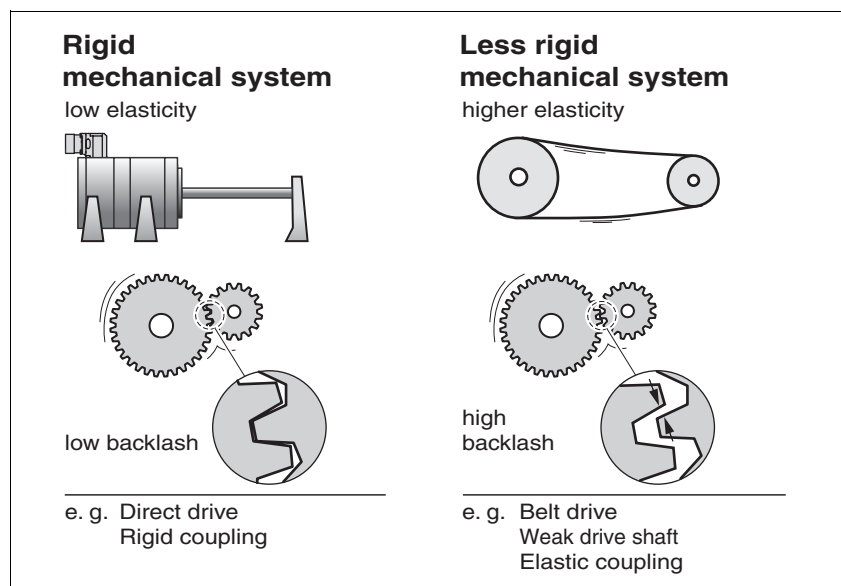

Figure 7.8 Rigid and less rigid mechanical systems

- ▶ Couple the motor and the mechanical system
- ▶ If you use limit switches, verify their function after installation of the motor.

Switching off the reference value filter of the speed controller

The reference value filter allows you to improve the transient response with optimized speed control. The reference value filter must be switched off when you set the speed controller for the first time.

- ▶ Disable the reference value filter of the speed controller. Set the parameter CTRL_TAUref to the minimum limit value "0".

Parameter Name	Description	Unit Minimum value Default value Maximum value	Data type R/W persistent Expert	Parameter address via fieldbus
CTRL_TAUref	Filter time constant ref.value filter of the ref. speed value	ms 0.00 0.00 327.67	UINT16 R/W per. -	Modbus 4626



Determining control parameter values for rigid mechanical systems

The procedure for optimization of the settings is only a suggestion. It is responsibility of the user to decide whether the method is suitable for the actual application.

Prerequisites for tuning the control performance as per the table comprise:

- Known and constant inertia of load and motor
- Rigid mechanical system

The P-factor CTRL_KPn and the correction time CTRL_TNn depend on:

- J_L : Mass moment of inertia of the load
- J_M Mass moment of inertia of the motor

- ▶ Determine the controller values based on Table 7.1:

J_L [kgcm ²]	$J_L = J_M$		$J_L = 5 * J_M$		$J_L = 10 * J_M$	
	KPn	TNn	KPn	TNn	KPn	TNn
1	0.0125	8	0.008	12	0.007	16
2	0.0250	8	0.015	12	0.014	16
5	0.0625	8	0.038	12	0.034	16
10	0.125	8	0.075	12	0.069	16
20	0.25	8	0.15	12	0.138	16

Table 7.1 Determining controller values

Determining controller values with less rigid mechanics

For optimization purposes the P-factor of the speed controller at which the controller adjusts the speed $_n_{act}$ as quickly as possible without overshooting is determined.

- ▶ Set the correction time CTRL_TNn to infinite.
CTRL_TNn = 327.67 ms.

If a load torque is acting on the stationary motor, the correction time must be set just high enough to prevent an uncontrolled change of the motor position.

019844113652, V2.00, 11.2008



In the case of drive systems in which the motor is under load while at standstill, for example vertical axes, setting the integral action time to "Infinite" may result in unwanted position deviations so that the value needs to be reduced. However, this can adversely affect optimization results.

⚠ WARNING

UNEXPECTED MOVEMENT

The jump function moves the motor in speed mode at constant speed until the specified time has expired.

- Check that the selected values for speed and time do not exceed the available distance.
- If possible, use limit switches or stop as well.
- Make sure that a functioning button for EMERGENCY STOP is within reach.
- Make sure that the system is free and ready for the motion before starting the function.

Failure to follow these instructions can result in death, serious injury or equipment damage.

- ▶ Initiate a jump function.
- ▶ After the first test check the maximum amplitude for the current set-point `_Iq_ref`.

Set the amplitude of the reference value just high enough so the reference value for the current `_Iq_ref` remains below the maximum value `CTRL_I_max`. On the other hand, the value selected should not be too low, otherwise friction effects of the mechanical system will determine the performance of the control loop.

- ▶ Trigger another step function if you had to to modify `_n_ref` and check the amplitude of `_Iq_ref`.
- ▶ Increase or decrease the P term in small increments until `_n_act` is obtained as fast as possible. The following diagram shows the required transient response on the left. Overshooting - as shown on the right - is reduced by reducing `CTRL_KPn`.

Deviations from $_n_ref$ and $_n_act$ result from setting CTRL_TNn to "Infinite".

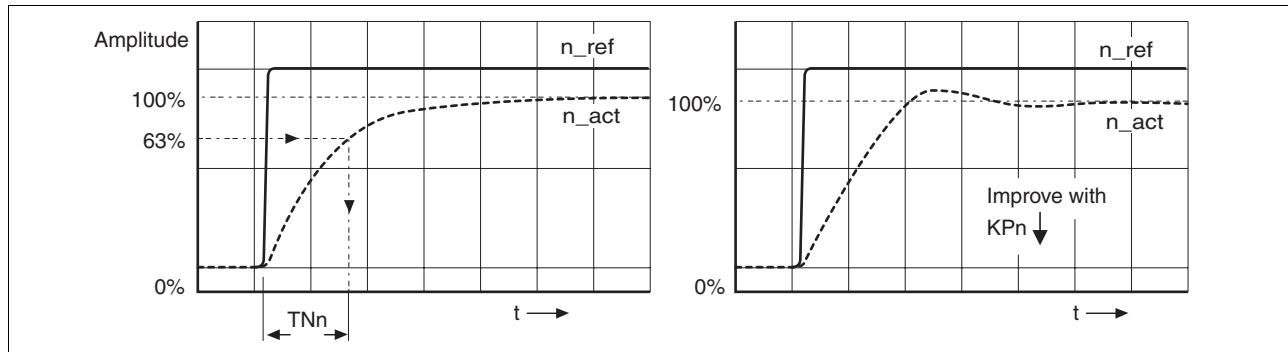

Figure 7.9 Determining "TNn" for the aperiodic limit



In the case of drive systems in which oscillations occur before the aperiodic limit is reached, the P-term "KPn" must be reduced to until oscillations can no longer be detected. This occurs frequently in the case of linear axes with a toothed belt drive.

Graphic determination of the 63% value

Graphically determine the point at which the actual speed $_n_act$ reaches 63% of the final value. The integral action time CTRL_TNn then results as a value on the time axis. The commissioning software supports you with the evaluation:

Problems during optimization

High-frequency resonance in mechanical components may interfere with controller optimization. The values for CTRL_KPn and CTRL_TNn cannot be set satisfactorily if this occurs.

7.3.4 Checking and optimizing default settings

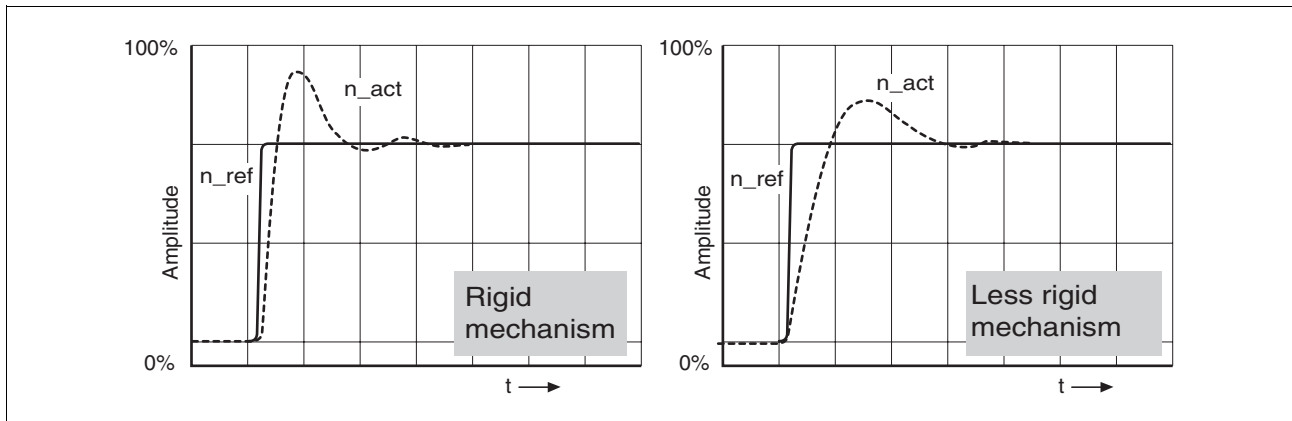

Figure 7.10 Step responses with good control performance

The controller is properly set when the jump response is approximately identical to the signal path shown. Good control response can be recognized by

- Fast adjustment
- Overshooting up to a maximum of 40% - 20% is recommended.

If the control response does not correspond to the curve shown, change CTRL_KPn in steps of about 10% and then initiate a jump function once again:

- If the controller is too slow: select CTRL_KPn greater.
- If the controller tends to oscillate: select CTRL_KPn smaller.

Oscillation ringing is characterized by continuous acceleration and deceleration of the motor.

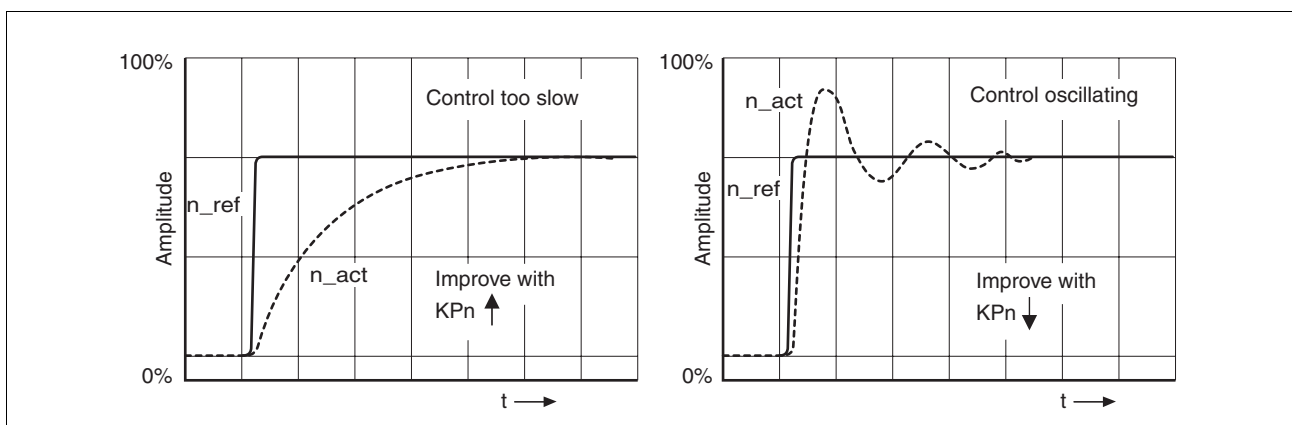

Figure 7.11 Optimizing inadequate speed controller settings



If the controller performance remains unsatisfactory in spite of optimization, contact your local sales representative.

7.3.5 Optimizing the position controller

Optimization requires good control dynamics in the subordinate speed control circuit.

When tuning the position controller, you must optimize the P term CTRL_KPp in two limits:

- CTRL_KPp too high: Overshooting of the mechanical system, instability of the closed-loop control
- CTRL_KPp too low: High position deviation

Parameter Name	Description	Unit Minimum value Default value Maximum value	Data type R/W persistent Expert	Parameter address via fieldbus
CTRL_KPp	Position controller P-term The default value is calculated.	1/s 2.0 - 495.0	UINT16 R/W per. -	Modbus 4620

▲ WARNING

UNEXPECTED MOVEMENT

The jump function moves the motor in speed mode at constant speed until the specified time has expired.

- Check that the selected values for speed and time do not exceed the available distance.
- If possible, use limit switches or stop as well.
- Make sure that a functioning button for EMERGENCY STOP is within reach.
- Make sure that the system is free and ready for the motion before starting the function.

Failure to follow these instructions can result in death, serious injury or equipment damage.

Setting the reference signal

- ▶ Select Position Controller as the reference value generator in the commissioning software.
- ▶ Set the reference signal:
 - Signal type: "Step"
 - Set the amplitude to approx. 1/10 motor revolution.

The amplitude is entered in user-defined units. With the default scaling, the resolution is 16384 usr per motor revolution.

Selecting recording signals

- ▶ Select the values in General Recording Parameters:
 - Setpoint of the position controller `_p_refusr` (`_p_ref`)
 - Actual position of the position controller `_p_actusr` (`_p_act`)
 - actual speed `_n_act`
 - current motor current `_Iq_ref`

019844113652, V2.00, 11.2008

Controller values for the position controller can be changed in the same parameter group used for the speed controller.

Optimizing the position controller value

- ▶ Trigger a step function with the default controller values.
- ▶ After the first test, check the values achieved for $_n_act$ and $_Iq_ref$ for current and speed control. The values must reach the current and speed limitation range.

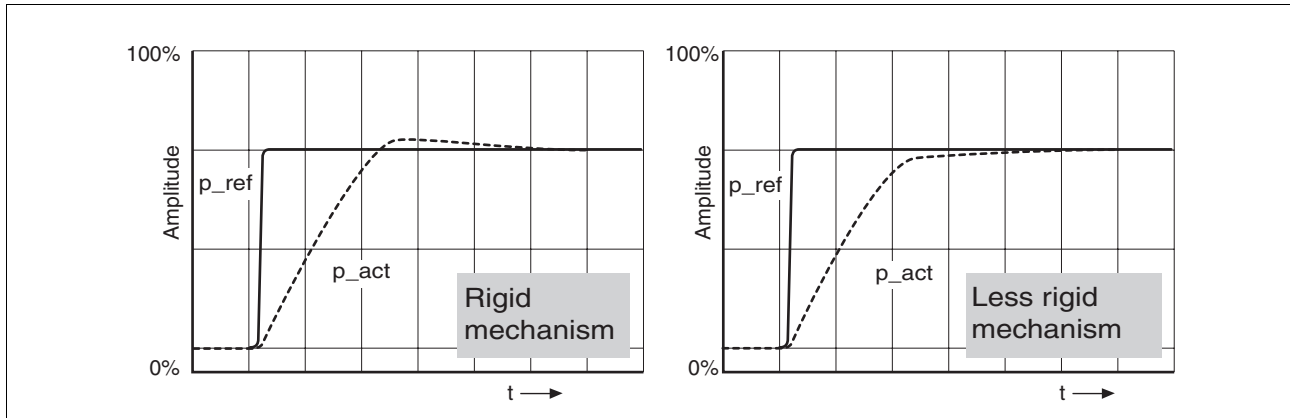

Figure 7.12 Step responses of a position controller with good control performance

The setting of the proportional term $CTRL_KPp$ is optimal if the reference value is reached rapidly and with little or no overshooting.

If the control performance does not correspond to the curve shown, change the P term $CTRL_KPp$ in increments of approx. 10% and trigger another step function.

- If the closed-loop control tends to oscillate: Use a lower $CTRL_KPp$ value.
- If the actual value is too slow reaching the reference value: Use a higher $CTRL_KPp$ value.

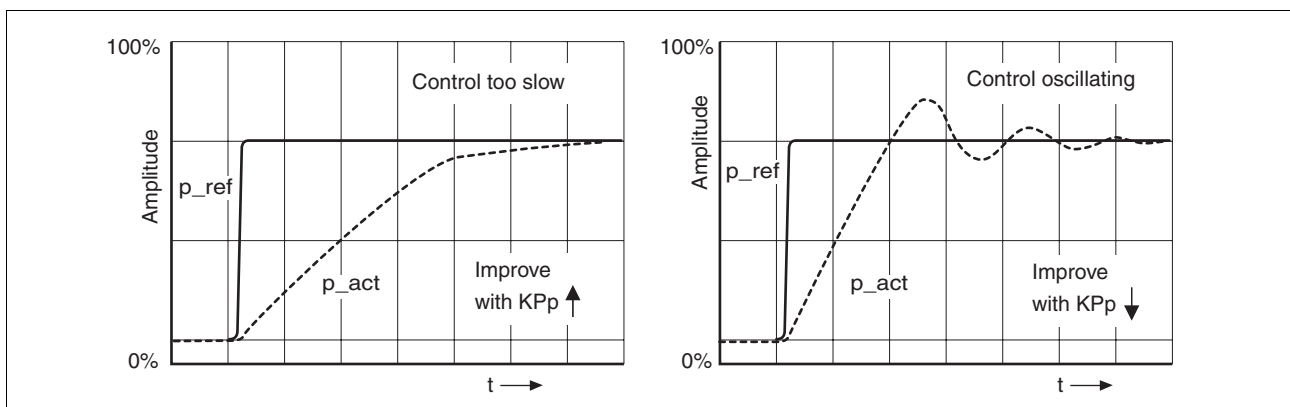

Figure 7.13 Optimizing insufficient position controller settings

8 Operation

The chapter "Operation" describes the basic operating states, operating modes and functions of the device.

⚠ WARNING

UNINTENDED BEHAVIOR

The behavior of the drive system is governed by numerous stored data or settings. Unsuitable settings or data may trigger unexpected movements or responses to signals and disable monitoring functions.

- Do NOT operate the drive system with unknown settings or data.
- Verify that the stored data and settings are correct.
- When commissioning, carefully run tests for all operating states and potential fault situations.
- Verify the functions after replacing the product and also after making changes to the settings or data.
- Only start the system if there are no persons or obstructions in the hazardous area.

Failure to follow these instructions can result in death, serious injury or equipment damage.



*An alphabetically sorted overview of **all** parameters can be found in the chapter "Parameters". The use and the function of some parameters are explained in more detail in this chapter.*

8.1 Overview of operating modes

The following table shows an overview of the operating modes and the way reference values are supplied.

Operating mode	Reference value supply	Description
Jog	Fieldbus commands	Page 127
Speed Control	Fieldbus commands	Page 131
Profile Position	Fieldbus commands	Page 132
Profile Velocity	Fieldbus commands	Page 136
Homing	Fieldbus commands	Page 138

Reference value for control loop

The following table shows the relationship between operating mode, control loop and the use of the profile generator.

Operating mode	Control loop	Profile generator
Jog	Position controller	X
Speed Control	Speed controller	-
Profile Position	Position controller	X
Profile Velocity	Position controller	X
Homing	Position controller	X

8.2 Access control

The device has several access channels. Using an access channel, you can control the device (for example, state transitions or motor movements).

An access channel can be assigned exclusive access control. With exclusive access control, you can only control the device via this access channel.

The device has the following access channels:

- Ethernet fieldbus
- Commissioning software
- Signal inputs
- Web server

8.2.1 Via Ethernet fieldbus

You can use the `AccessLock` parameter to restrict access control to the fieldbus. In this case, the product can no longer be controlled via another access channel.

Parameter Name	Description	Unit Minimum value Default value Maximum value	Data type R/W persistent Expert	Parameter address via fieldbus
AccessLock	Locking other access channels 0: Release other access channels 1: Lock other access channels The fieldbus can lock active access to the device via the following access channels with this parameter: - Input signals - Commissioning software Processing of the input signal HALT cannot be locked.	- 0 - 1	UINT16 R/W - -	Modbus 316

A separate access channel is assigned for each connection via Modbus TCP. The device can be controlled via a single channel only.

Special case I/O scanning

The Modbus Unit ID 255 is used for I/O scanning. All connections of a Modbus client that address the Modbus Unit ID 255 are combined to a single channel in the device.

Only one Modbus client can use this access channel. If messages from other Modbus clients are received with the Modbus Unit ID 255, the response to these requests is an error.

This access channel has access control by default. As long as the device is moving, access control cannot be revoked.

019844113652, V2.00, 11.2008

8.2.2 Via commissioning software

With the "Access" field, you can restrict access control to the commissioning software. In this case, the product can no longer be controlled via another access channel.

8.2.3 Via signal inputs

You can control the device using the functions of the signal inputs LIO1 ... LIO4. Control is not possible while another access channel has exclusive access control.

The following signal inputs are effective even if another access channel has exclusive access control.

- The digital signal inputs of the STO safety function.
- The digital signal inputs with the functions "Halt", "Positive limit switch (LIMP)", "Negative limit switch (LIMN)" and "Reference switch (REF)".

8.3 Operating states

8.3.1 State diagram

After switching on and when an operating mode is started, the product goes through a number of operating states.

The state diagram (state machine) shows the relationships between the operating states and the state transitions.

The operating states are monitored and influenced by internal monitoring functions and system functions such as temperature monitoring or current monitoring.

Graphic representation The state diagram is shown graphically as a flow chart.

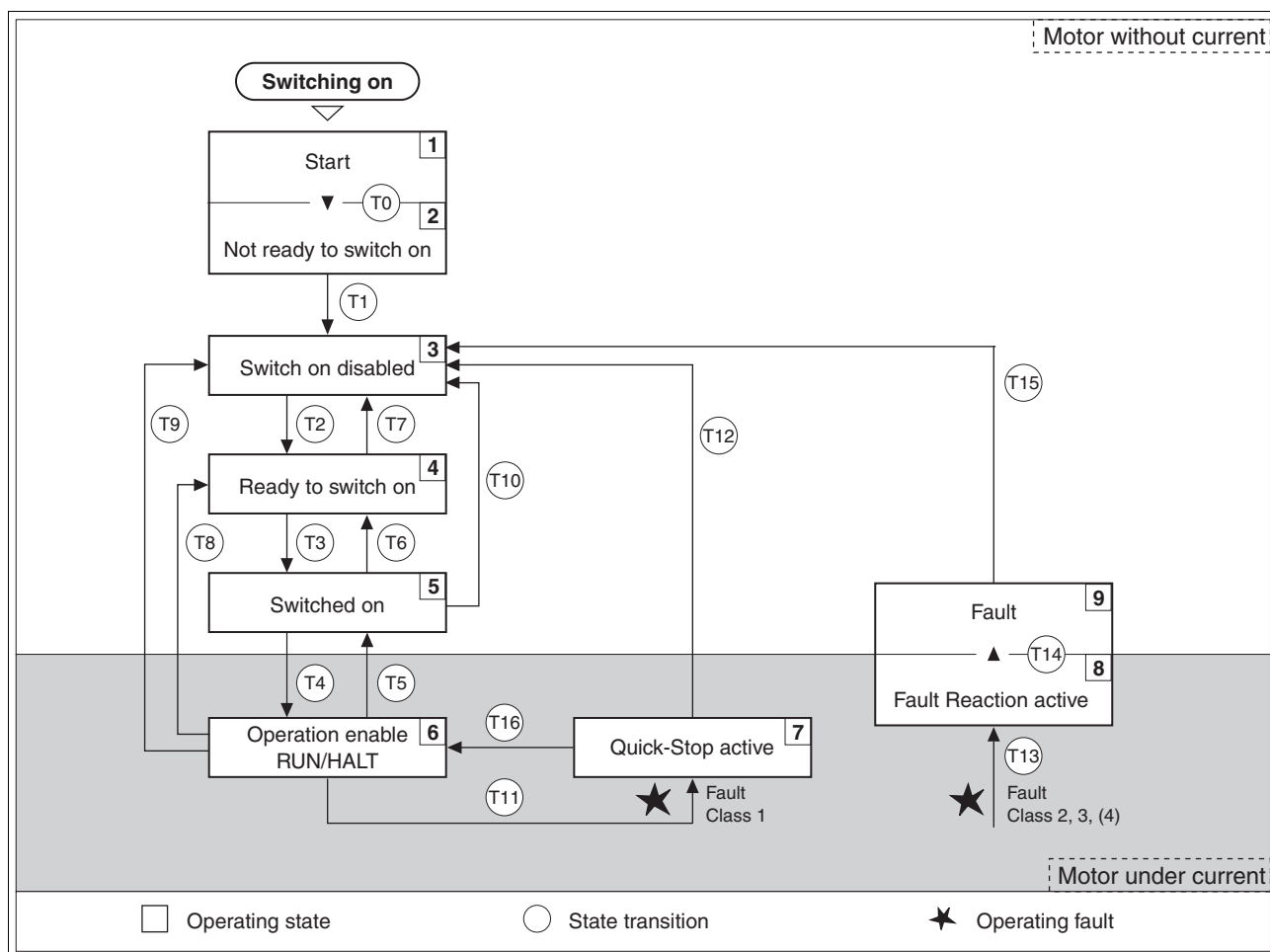

Figure 8.1 State diagram

019844113652, V2.00, 11.2008

Operating states You can display the operating states with the commissioning software.

Operating states	Description of operating states
1 Start	Controller supply voltage is switched on, initialization of electronics
2 Not ready to switch on	Power stage is not ready to switch on ¹⁾
3 Switch on disabled	Switching on the power stage is disabled
4 Ready to switch on	The power stage is ready to be switched on
5 Switched on	Motor without current Power stage ready No operating mode active
6 Operation enable	RUN: Device is running in the selected operating mode HALT: The motor is stopped with power stage enabled
7 Quick Stop active	"Quick Stop" function executed
8 Fault response active	Error detected, response is active
9 Fault	Device is in fault state

1) The device must be switched off and then switched on again

Error response The state transition T13 (error class 2, 3 or 4) initiates an error response as soon as an internal occurrence signals an error to which the device must react.

Error class	State from -> to	Response
2	x -> 8	Braking with "Quick Stop" Brake is applied Power stage is disabled
3,4 or Safety function STO	x -> 8 -> 9	Power stage is disabled immediately, even if "Quick Stop" is still active

An operating error can be triggered by a temperature sensor, for example. The device cancels the motion command and starts the error response, e.g. deceleration and stopping with "Quick Stop" or disabling the power stage. Subsequently, the operating state changes to "Fault".

To exit the "Fault" operating state, the cause of the error must be remedied and a "Fault Reset" must be executed.

In the event of a "Quick Stop" triggered by errors of class 1 (operating state 7), a "Fault Reset" returns you directly to operating state 6.

State transitions State transitions are triggered by an input signal, a fieldbus command or as a response to a monitoring signal.

Transition	Operating state	Condition / event ^{1) 2)}	Response
T0	1-> 2	• Device electronics successfully initialized	
T1	2-> 3	• Parameter successfully initialized	

Transition	Operating state	Condition / event ^{1) 2)}	Response
T2	3 -> 4	<ul style="list-style-type: none"> No undervoltage Encoder successfully checked Actual speed: <1000 min⁻¹ $\overline{STO_A}$ ($\overline{PWRR_A}$) and $\overline{STO_B}$ ($\overline{PWRR_B}$) = +24V (or jumper CN6 plugged in) Fieldbus command: Shutdown ³⁾ 	
T3	4 -> 5	<ul style="list-style-type: none"> Request for enabling the power stage Fieldbus command: Switch On 	
T4	5 -> 6	<ul style="list-style-type: none"> Automatic transition Fieldbus command: Enable Operation (only if T3 via fieldbus command Switch On) 	Power stage is enabled User-defined parameters are checked Holding brake is released (if available)
T5	6 -> 5	<ul style="list-style-type: none"> Fieldbus command: Disable Operation 	Motion command is canceled with "Halt" Brake is applied Power stage is disabled
T6	5 -> 4	<ul style="list-style-type: none"> Fieldbus command: Shutdown 	
T7	4 -> 3	<ul style="list-style-type: none"> Undervoltage $\overline{STO_A}$ ($\overline{PWRR_A}$) and $\overline{STO_B}$ ($\overline{PWRR_B}$) = 0V Actual speed: >1000 min⁻¹ (for example by external driving force) Fieldbus command: Disable Voltage 	-
T8	6 -> 4	<ul style="list-style-type: none"> Fieldbus command: Shutdown 	Power stage is immediately disabled.
T9	6 -> 3	<ul style="list-style-type: none"> Request for disabling the power stage Fieldbus command: Disable Voltage 	Power stage is immediately disabled.
T10	5 -> 3	<ul style="list-style-type: none"> Request for disabling the power stage Fieldbus command: Disable Voltage 	
T11	6 -> 7	<ul style="list-style-type: none"> Class 1 error Fieldbus command: Quick Stop 	Motion command is canceled with "Quick Stop".
T12	7 -> 3	<ul style="list-style-type: none"> Request for disabling the power stage Fieldbus command: Disable Voltage 	Power stage is disabled immediately, even if "Quick Stop" is still active.
T13	x -> 8	<ul style="list-style-type: none"> Errors Class 2, 3 or 4 	Error response is carried out, see "Error response"
T14	8 -> 9	<ul style="list-style-type: none"> Error response terminated (error from class ²⁾ Errors Class , 3 or 4 	
T15	9-> 3	<ul style="list-style-type: none"> Function: "Fault Reset" 	Error is reset (cause of error must be corrected).
T16	7 -> 6	<ul style="list-style-type: none"> Function: "Fault reset" Fieldbus command: Enable Operation ⁴⁾ 	

1) In order to initiate a state transition it is sufficient if one condition is met

2) Fieldbus commands only with fieldbus control mode

3) Only required with fieldbus control mode, fieldbus CANopen and parameter DCOMcompatib= 1

4) Possible only if operating state was triggered via the fieldbus

8.3.2 Indicating the operating states

You can indicate the current operating state via the signal outputs, the commissioning software or the fieldbus.

Via signal outputs Indication of the operating states via the signal outputs must be configured, see chapter 8.6.9 "Configurable inputs and outputs".

State	"No fault"	"Active"
2: Not ready to switch on	0	0
3: Switch on disabled	0	0
4: Ready to switch on	1	0
5: Switched on	1	0
6: Operation enable	1	1
7: Quick Stop activ	0	0
8: Fault Reaction active	0	0
9: Fault	0	0

Via the fieldbus The operating state is indicated via the signal inputs, the fieldbus or the commissioning software.

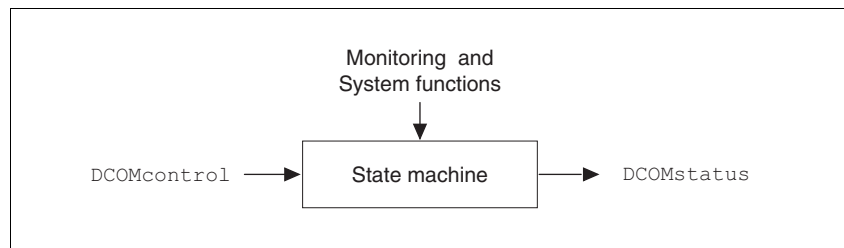

Figure 8.2 Changing and monitoring the operating state via parameters

Status information The parameter `DCOMstatus` provides global information on the operating state of the unit and the processing state.

Parameter Name HMI menu	Description	Unit Minimum value Default value Maximum value	Data type R/W persistent Expert	Parameter address via fieldbus
DCOMstatus	Drivecom status word Refer to chapter Operation, State Machine for bit coding information. Bit 0-3,5,6: Status bits Bit 4: Voltage enabled Bit 7: Warning Bit 8: HALT request active Bit 9: Remote Bit 10: Target reached Bit 11: Reserved Bit 12: Operating mode specific Bit 13: x_err Bit 14: x_end Bit 15: ref_ok	- - 0 -	UINT16 R/- -	Modbus 6916

Bit 0, 1, 2, 3, 5 and 6 Bits 0, 1, 2, 3, 5 and 6 of the `DCOMstatus` parameter provide information about the operating state.

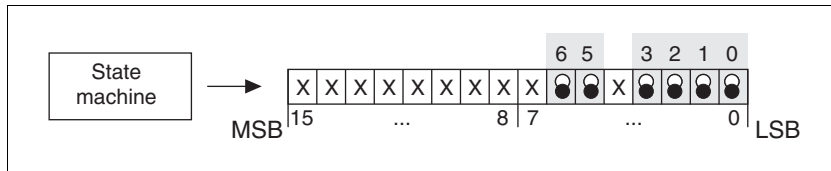

Figure 8.3 Display of operating status

Operating status	Bit 6 Switch on disable	Bit 5 Quick Stop	Bit 3 Fault	Bit 2 Operation enable	Bit 1 Switch On	Bit 0 Ready to switch on
2: Not ready to switch on	0	X	0	0	0	0
3: Switch on disabled	1	X	0	0	0	0
4: Ready to switch on	0	1	0	0	0	1
5: Switched on	0	1	0	0	1	1
6: Operation enable	0	1	0	1	1	1
7: Quick Stop active	0	0	0	1	1	1
8: Fault Reaction active	0	X	1	1	1	1
9: Fault	0	X	1	1	1	1

Bit 4, Voltage enabled Bit 4=1 indicates whether the DC bus voltage is correct. If the voltage is missing or is too low, then the device does not change from state 3 to state 4.

Bit 7, Warning Bit 7 becomes 1 if parameter `_WarnActive` contains a warning message. The movement is not interrupted. The bit remains set as long as a warning message is contained in parameter `_WarnActive`. The bit remains set for at least 100ms, even if a warning message is active for a shorter time. The bit is reset immediately with a "Fault Reset".

Bit 8, Halt request active Bit 8=1 indicates that a "Halt" is active.

Bit 9, Remote If Bit 9 is set, the device carries out commands via the fieldbus. If Bit 9 is reset, the device is controlled via a different interface. In such a case, it is still possible to read or write parameters.

Bit 10, target reached Bit 10 only becomes "1", if the operating mode is terminated successfully and the motor has come to a standstill. Bit 10 has the value "0" as long as the motor is running, if the operating mode is interrupted by a "Halt" or canceled because of an error.

Bit 11 Reserved.

Bit 12 Bit 12 is used for monitoring the current operating mode. Details can be found in the chapters on the individual operating modes.

Bit 13, x_err Bit 13 only becomes "1" in the case of an error which needs to be remedied prior to further processing. The device responds corresponding to the error class.

019844113652, V2.00, 11.2008

- Bit 14, x_end* Bit 14 changes to "0" if an operating mode is started. When processing is terminated or interrupted, for example by a "Halt", Bit 14 toggles back to "1" once the motor has come to a standstill.
The signal change of bit 14 to "1" is suppressed if one process is followed immediately by a new process in a different operating mode.
- Bit 15, ref_ok* Bit 15 is "1" if the motor or the axis has a valid reference point, for example as a result of a reference movement. A valid reference point remains valid even if the power stage is disabled.

8.3.3 Changing operating states

You can switch the operating state via the commissioning software or the fieldbus.

Via signal inputs The operating state is changed either via the commissioning software, the signal inputs or automatically.

Input signal	State transitions	State transition to
ENABLE 0 -> 1	T3, T4	6: Operation enable
ENABLE 1 -> 0	T5, T6	4: Ready to switch on
FAULT_RESET 0 -> 1	T15 T16	4: Ready to switch on 6: Operation enable

Via the fieldbus The operating states are either set via the commissioning software or the parameter DCOMcontrol. Bits 0 to 3 and Bit 7 are relevant for state transitions.

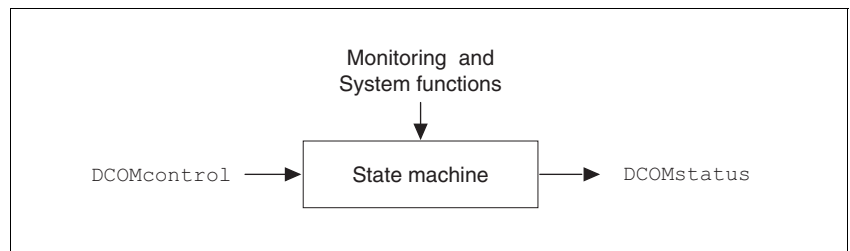

Figure 8.4 Changing and monitoring the operating state via parameters

Parameter Name HMI menu	Description	Unit Minimum value Default value Maximum value	Data type R/W persistent Expert	Parameter address via fieldbus
DCOMcontrol	Drivecom control word Refer to chapter Operation, Operating States, for bit coding information. Bit 0: Switch on Bit 1: Enable Voltage Bit 2: Quick Stop Bit 3: Enable Operation Bit 4..6: Operating mode specific Bit 7: Fault Reset Bit 8: Halt Bit 9..15: Reserved (must be 0)	- 0 -	UINT16 R/W	Modbus 6914

019844113652, V2.00, 11.2008

Bits 0 to 3 and 7

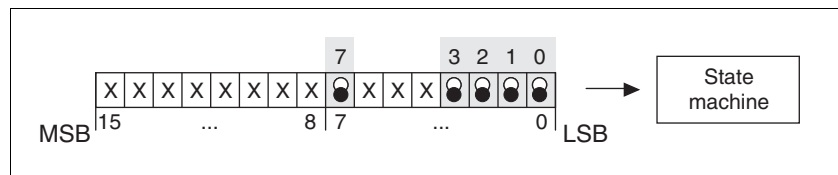

Figure 8.5 Changing the operating state

Fieldbus command	State transitions	State transition to	Bit 7, Reset Fault	Bit 3, Enable operation	Bit 2, Quick Stop	Bit 1, Enable Voltage	Bit 0, Switch On
Shutdown	T2, T6, T8	4: Ready to switch on	X	X	1	1	0
Switch On	T3	5: Switched on	X	X	1	1	1
Disable Voltage	T7, T9, T10, T12	3: Switch on disabled	X	X	X	0	X
Quick Stop	T7, T10T11	3: Switch on disabled 7: Quick Stop active	X	X	0	1	X
Disable Operation	T5	5: Switched on	X	0	1	1	1
Enable operation	T4, T16	6: Operation enable	X	1	1	1	1
Fault reset	T15	3: Switch on disabled	0->1	X	X	X	X

The bit states in the fields marked with "X" have no meaning for the corresponding state transition.

Bits 4 to 6 Bits 4 to 6 are used for the operating mode-specific settings. Details can be found in the descriptions of the individual operating modes in this chapter.

Bit 8, Halt A "Halt" can be triggered with bit 8=1.

Bits 9 to 15 Reserved.

8.4 Starting and changing operating modes

Prerequisites The device must be ready for operation and properly initialized for an operating mode to be started.

The product cannot run in two operating modes at the same time. If an operating mode is active, you can only change to a different operating mode if the current operating mode is terminated or canceled.

An operating mode is terminated if the drive is at a standstill, for example, if the target position of a positioning process is reached or if the drive is stopped by a "Quick Stop" or "Halt". If an error occurs during processing which causes the current operating mode to be canceled, the movement can be resumed or you can change to a different operating mode after the cause of the error has been removed.

Changing operating states and activating operating modes must be executed separately. An operating mode can normally only be activated if the operating state is already "Operation Enable".

8.4.1 Starting an operating mode

Via the fieldbus An operating mode is started using the parameter DCOMopmode.

The following table shows the sequence of parameters for starting an operating mode using the example of Jog mode.

Parameter	Meaning
1 JOGactivate	Activation of jog
2 DCOMopmode	Starting the operating mode (-3)

Parameter Name HMI menu	Description	Unit Minimum value Default value Maximum value	Data type R/W persistent Expert	Parameter address via fieldbus
JOGactivate	Activation of jog Bit 0: positive direction of rotation Bit 1: negative direction of rotation Bit 2: 0=slow 1=fast	- 0 0 7	UINT16 R/W - -	Modbus 6930
DCOMopmode	Operating mode DS402 operating modes: 1: Profile position 3: Profile velocity 6: Homing ----- Manufacturer operating modes: -1: Jog	- -6 - 6	INT16 R/W - -	Modbus 6918

In the case of the Profile Position and Homing mode, the device receives the instruction to start the set operating mode by Bit 4 in the parameter DCOMcontrol.

In the other operating modes, bits 4 to 6 are assigned specific to operating mode.

019844113652, V2.00, 11.2008

8.4.2 Changing the operating mode

Control via fieldbus The operating modes can be changed during operation. For this purpose, the current process must be completed or explicitly canceled. The drive must be at a standstill. Then proceed as described in "Starting an operating mode".

2 parameters are available for indicating the current operating mode and for changing the operating modes.

- Parameter for indication: `_DCOMopmd_act`
- Parameter for change: `DCOMopmode`

Parameter Name HMI menu	Description	Unit Minimum value Default value Maximum value	Data type R/W persistent Expert	Parameter address via fieldbus
<code>_DCOMopmd_act</code>	Active operating mode See DCOMopmode for coding	- -6 - 6	INT16 R/- - -	Modbus 6920
<code>DCOMopmode</code>	Operating mode DS402 operating modes: 1: Profile position 3: Profile velocity 6: Homing ----- Manufacturer operating modes: -1: Jog	- -6 - 6	INT16 R/W - -	Modbus 6918

8.5 Operating modes

8.5.1 Operating mode Jog

Overview of jog The motor moves by one jog unit or at constant speed of rotation in continuous operation. The length of the jog unit, the values for the speed of rotation and the waiting time prior to continuous operation can be set.

The current motor position is the start position for the Jog operating mode. The jog distance and the values for the speed of rotation are entered in user-defined units.

If a positive and a negative jog are requested at the same time, there is no motor movement.

Starting the operating mode In the case of fieldbus control mode, the operating mode must be set using the parameter `DCOMopmode`.

With the start signal for the jog movement, the motor first moves by a defined jog distance `JOGstepusr`. If the start signal is still available after a specified waiting time `JOGtime`, the device switches to continuous operation until the start signal is canceled.

The illustration below shows an overview of control via signal inputs.

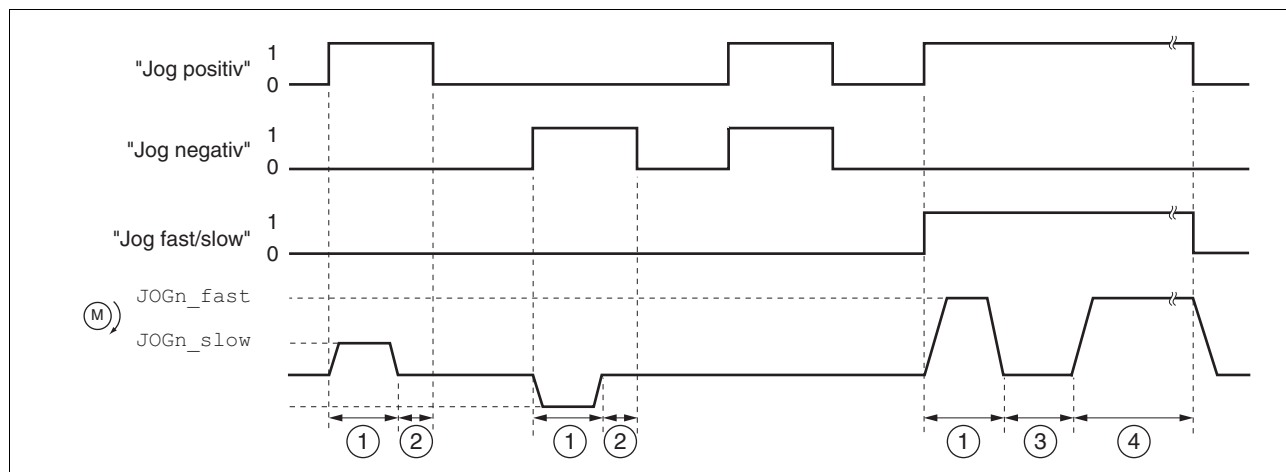

Figure 8.6 Jog, slow and fast

The illustration below shows an overview of control via the fieldbus.

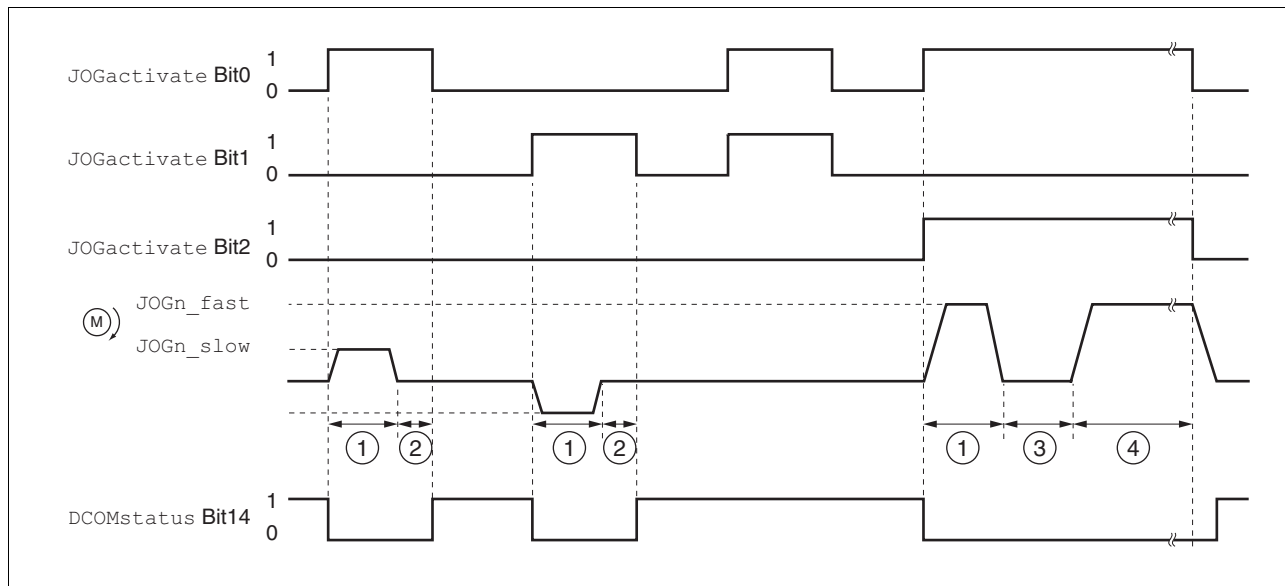

Figure 8.7 Jog, slow and fast

- (1) Distance unit
- (2) $t < \text{waiting time}$
- (3) $t > \text{waiting time}$
- (4) Continuous operation

The distance unit, waiting time and speed levels can be set. If the distance unit is zero, the jog movement starts directly with continuous operation irrespective of the wait time.

Parameter Name HMI menu	Description	Unit Minimum value Default value Maximum value	Data type R/W persistent Expert	Parameter address via fieldbus
JOGactivate	Activation of jog Bit 0: positive direction of rotation Bit 1: negative direction of rotation Bit 2: 0=slow 1=fast	- 0 0 7	UINT16 R/W - -	Modbus 6930
JOGn_slow	Speed for slow jog The adjustable value is internally limited to the current parameter setting in RAMPn_max.	min ⁻¹ 1 60 13200	UINT16 R/W per. -	Modbus 10504
JOGn_fast	Speed for fast jog The adjustable value is internally limited to the current parameter setting in RAMPn_max.	min ⁻¹ 1 180 13200	UINT16 R/W per. -	Modbus 10506
JOGstepusr	Jog distance prior to continuous run 0: Direct activation of continuous run >0: Positioning distance per jog cycle	usr 0 20 2147483647	INT32 R/W per. -	Modbus 10510
JOGtime	Wait time prior to continuous run This time is only effective if you have set a jog distance not equal to 0, otherwise the drive immediately starts a continuous run.	ms 1 500 32767	UINT16 R/W per. -	Modbus 10512

Parameter Name HMI menu	Description	Unit Minimum value Default value Maximum value	Data type R/W persistent Expert	Parameter address via fieldbus
RAMPacc	Acceleration of profile generator	min ⁻¹ /s 1 600 3000000	UINT32 R/W per. -	Modbus 1556
RAMPdecel	Deceleration of profile generator	min ⁻¹ /s 750 750 3000000	UINT32 R/W per. -	Modbus 1558
RAMP_TAUjerk	Jerk limitation 0 / off: Off 1 / 1: 1 ms 2 / 2: 2 ms 4 / 4: 4 ms 8 / 8: 8 ms 16 / 16: 16 ms 32 / 32: 32 ms 64 / 64: 64 ms 128 / 128: 128 ms Limits the acceleration change (jerk) of the reference position generation during the positioning transitions: Standstill - acceleration Acceleration - constant speed Constant speed - deceleration Deceleration - standstill Processing in the following operating modes: - Profile velocity - Profile position - Jog - Homing Adjustments can only be made if the operating mode is inactive (x_end=1).	ms 0 0 128	UINT16 R/W per. -	Modbus 1562

Status messages The drive provides information concerning positioning via Bits 10 and 12 to 15 in the parameter DCOMstatus.

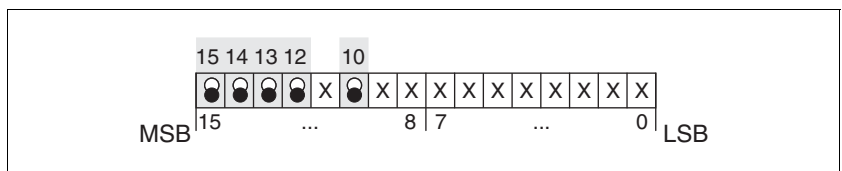

Figure 8.8 Status messages for operating mode

Parameter value	Meaning
Bit 10: target reached	Not relevant in this operating mode
Bit 12: Operating-mode-dependent	Reserved
Bit 13: x_err	1: Error
Bit 14: x_end	1: Mode completed, motor at a standstill
Bit 15: ref_ok	1: drive has valid reference point

019844113652, V2.00, 11.2008

- Terminating the operating mode* Jog is finished when the motor has come to a standstill and
- the direction signal is inactive,
 - the operating mode has been interrupted by "Halt" or an error
- Further options* Jog can also be assigned to digital inputs. It is possible to assign Jog positive, Jog negative and Jog slow/fast to one input each.
- For further settings and functions for the operating mode, see page 152.

8.5.2 Operating mode Speed control

Overview of Speed Control In the Speed Control operating mode, a reference value for the speed of rotation of the motor is preset.

Transitions between two speeds of rotation follow the adjusted control loop parameters.

Starting the operating mode In the case of fieldbus control mode, the operating mode must be set using the parameter `DCOMopmode`. Writing the parameter value `SPEEDreference` causes the operating mode to start. The parameter `SPEEDn_target` defines the reference value.

Setting limit values See chapter 7.2.7 "Setting basic parameters and limit values" for setting the limitation of the current and the speed of rotation.

Parameter Name HMI menu	Description	Unit Minimum value Default value Maximum value	Data type R/W persistent Expert	Parameter address via fieldbus
SPEEDreference	Selection of the ref. value source for op. mode speed control 0 / none: None 2 / Parameter 'speedTarg': Reference value via parameter <code>SPEEDn_target</code>	- 0 0 2	UINT16 R/W - -	Modbus 6946
SPEEDn_target	Reference speed in operating mode speed control The internal maximum speed is limited to the current setting in <code>CTRL_n_max</code> .	min ⁻¹ -30000 0 30000	INT16 R/W - -	Modbus 8456

Status messages The drive provides information concerning positioning via Bits 10 and 12 to 15 in the parameter `DCOMstatus`.

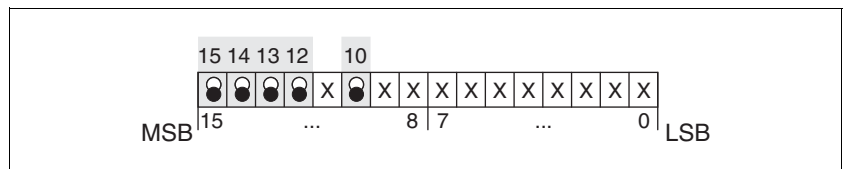

Figure 8.9 Status messages for operating mode

Parameter value	Meaning
Bit 10: target reached	Not relevant in this operating mode
Bit 12: Operating-mode-dependent	Reserved
Bit 13: <code>x_err</code>	1: Error
Bit 14: <code>x_end</code>	1: Mode completed, motor at a standstill
Bit 15: <code>ref_ok</code>	1: drive has valid reference point

Terminating the operating mode Processing is terminated by:

- Deactivation of the operating mode and standstill of motor
- Standstill of motor caused by "Halt" or by an error

019844113652, V2.00, 11.2008

8.5.3 Operating mode Profile position

In Profile Position operating mode, a movement with an adjustable motion profile is performed from a start position to a target position. The value of the target position can be specified as either a relative or an absolute position.

You can set a motion profile with values for acceleration ramp, deceleration ramp and target speed.

Relative and absolute positioning

In the case of absolute positioning, the positioning distance is specified absolutely with reference to the zero point of the axis. A zero point must be defined with the Homing operating mode before absolute positioning can be used for the first time.

In the case of a relative positioning, the positioning distance is specified relatively with reference to the current axis position or the target position.

Absolute positioning or relative positioning is set with bit 6 via the parameter `DCOMcontrol`.

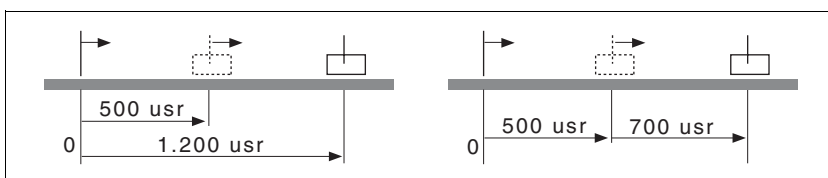

Figure 8.10 Absolute positioning (left) and relative positioning (right)

Triggering positioning

Parameter value	Meaning
Bit 4: New setpoint	0->1: start positioning or prepare following positioning
Bit 5: Change set immediately (Only applicable with New setpoint 0->1)	0: Enable new positioning values when target position is reached 1: Enable new position values immediately
Bit 6: Absolute / relative	0: Absolute positioning 1: Relative positioning

Start positioning with a rising edge of Bit 4 in the parameter `DCOMcontrol`.

The positioning can be triggered in 2 ways depending upon Bit 5.

- Bit 5=0:

Position values (PPp_targetusr, PPn_target, RAMPacc and RAMPdecel), that are transferred during a positioning, are saved temporarily. The target position of the current positioning is approached. The new position values are executed only when the target position is reached.

If new position values are transferred again, the temporarily saved position values are overwritten again.

- Bit 5=1:

Position values (PPp_targetusr, PPn_target, RAMPacc and RAMPdecel), that are transferred during a positioning, are executed immediately. The target position of the new positioning is directly approached.

Status messages

The drive provides information concerning positioning via Bits 10 and 12 to 15 in the parameter DCOMstatus.

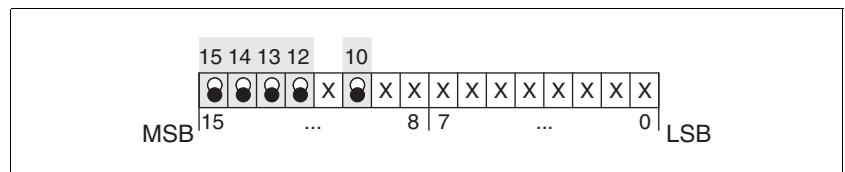

Figure 8.11 Status reports for operating mode

Parameter value	Description
Bit 10: Target reached	0: Target position not reached (even with "Halt" or error) 1: Target position reached
Bit 12: setpoint acknowledge	0: Transfer of new position possible 1: New target positioning accepted
Bit 13: x_err	1: Error arisen
Bit 14: x_end	1: Positioning completed, motor at a standstill
Bit 15: ref_ok	1: drive has valid reference point

Positioning finished

Bit 14 indicates whether positioning is complete. If this includes reaching the target position, then Bit 10 changes to 1. If the positioning has been interrupted by a "Halt" or a fault, Bit 10 remains at 0.

019844113652, V2.00, 11.2008

8.5.3.1 Parameterization

The Profile Position operating mode can be set and executed via parameters.

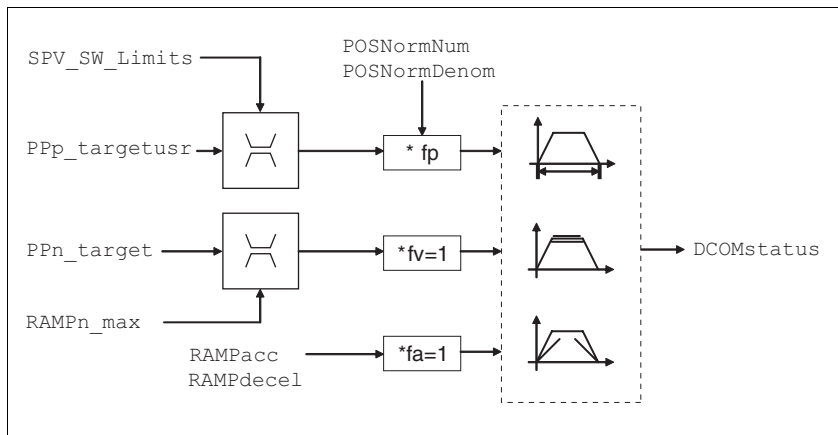

Figure 8.12 Operating mode Profile Position, effect of adjustable parameters

Target position A new position value is assigned with the parameter `PPp_targetusr`. In the case of absolute positioning, the positioning distance is specified absolutely with reference to the zero point of the axis. In the case of a relative positioning, the positioning distance is specified relatively with reference to the current axis position or the target position. This depends on the setting in parameter `PPoption`.

Parameter Name HMI menu	Description	Unit Minimum value Default value Maximum value	Data type R/W persistent Expert	Parameter address via fieldbus
PPn_target	Reference speed in operating mode profile position The maximum value is limited to the current setting in CTRL_n_max. The adjusted value is internally limited to the current parameter value in RAMPn_max.	min ⁻¹ 1 60 -	UINT32 R/W - -	Modbus 6942
PPoption	Options for operating mode profile position Determines the reference position for relative positioning: 0: Relative with reference to the previous target position of the motion profile generator 1: Not supported 2: Relative with reference to the actual position of the motor	- 0 0 2	UINT16 R/W - -	Modbus 6960
AbsHomeRequest	Absolute positioning only after homing 0 / no: No 1 / yes: Yes	- 0 0 1	UINT16 R/W per. -	Modbus 1580
PPp_targetusr	Target position in operating mode profile position Min./max values depend on: - Scaling factor - Software limit switches (if they are activated)	usr - 0 -	INT32 R/W - -	Modbus 6940

Current position The current position can be determined with the 2 parameters `_p_actusr` and `_p_actRAMPusr`.

Parameter Name HMI menu	Description	Unit Minimum value Default value Maximum value	Data type R/W persistent Expert	Parameter address via fieldbus
<code>_p_actusr</code>	Actual motor position in user units	usr - 0 -	INT32 R/- - -	Modbus 7706
<code>_p_actRAMPusr</code>	Actual position of motion profile generator In user units	usr - 0 -	INT32 R/- - -	Modbus 7940

8.5.4 Operating mode Profile velocity

In the operating mode Profile Velocity, the drive accelerates to an adjustable target speed of rotation. You can set a motion profile with values for acceleration and deceleration ramps.

Start operating mode If the type of operation, the operating state and the parameter values are set, the operating mode can be started by transfer of a set velocity in the parameter PVn_target.

Status messages The drive provides information concerning positioning via Bits 10 and 12 to 15 in the parameter DCOMstatus.

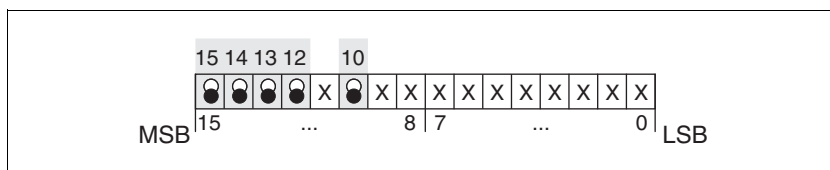

Figure 8.13 Status reports for operating mode

Parameter value	Description
Bit 10: Target reached	0: Reference speed not reached 1: Reference speed reached (even in the event of motor standstill via "Halt")
Bit 12: speed=0	0: motor moves 1: motor stopped
Bit 13: x_err	1: Error arisen
Bit 14: x_end	1: Operating mode finished
Bit 15: ref_ok	1: drive has valid reference point

Operating mode finished The operating mode is completed and motor standstill achieved by "Halt", by an error or after a preset default = 0.

8.5.4.1 Parameterization

Overview The following overview shows the function principle of the parameters which can be set for the Profile Velocity operating mode.

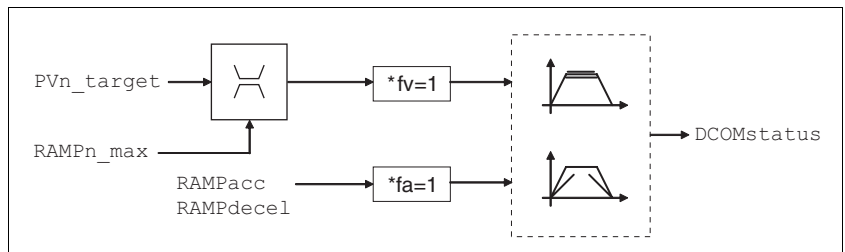

Figure 8.14 Operating mode Profile Velocity, effects of adjustable parameters

Set speed The set speed is transferred parameter PVn_target in rpm and can be changed during the movement. The operating mode is not limited by range limits of the positioning. New speed values are accepted immediately during a travel command.

Parameter Name HMI menu	Description	Unit Minimum value Default value Maximum value	Data type R/W persistent Expert	Parameter address via fieldbus
PVn_target	Reference speed in operating mode profile velocity The maximum value is limited to the current setting in CTRL_n_max. The adjusted value is internally limited to the current parameter value in RAMPn_max.	min ⁻¹ - 0 -	INT32 R/W - -	Modbus 6938

Current speed The current speed is determined by using the 2 parameters _n_act and _n_actRAMP.

Parameter Name HMI menu	Description	Unit Minimum value Default value Maximum value	Data type R/W persistent Expert	Parameter address via fieldbus
_n_act	Actual motor speed	min ⁻¹ - 0 -	INT16 R/- - -	Modbus 7696
_n_actRAMP	Actual speed of motion profile generator	min ⁻¹ - 0 -	INT32 R/- - -	Modbus 7948

8.5.5 Operating mode Homing

Overview of Homing The operating mode Homing establishes an absolute position reference between the motor position and a defined axis position. Homing can be carried out by a means of a reference movement or by position setting.

- A reference movement is a movement to a defined point, the reference point, on the axis; the objective is to establish the absolute position reference between the motor position and the axis position. The reference point also defines the zero point that is used for all subsequent absolute positioning movements as a reference point. It is possible to parameterize a shift of the zero point.

A reference movement must be completed for the new zero point to be valid. If the reference movement is interrupted, it must be started again. As opposed to the other operating modes, a reference movement must be completed before a new operating mode can be activated.

The signals required for the reference movement must be wired. Monitoring signals that are not used must be deactivated.

- Position setting lets you set the current motor position to a desired position value to which the subsequent position values will relate.



Homing is not required for a motor with a multiturn encoder because it provides a valid absolute position immediately after being switched on.

Types of reference movements

There are 4 standard types of reference movements:

- Movement to negative limit switch $\overline{\text{LIMN}}$
- Movement to positive limit switch $\overline{\text{LIMP}}$
- Movement to reference switch $\overline{\text{REF}}$ with counterclockwise direction of rotation
- Movement to reference switch $\overline{\text{REF}}$ with clockwise direction of rotation

Reference movements are possible with or without index pulse.

- Reference movement without index pulse
Movement from the switching edge to a distance distance from switching edge
- Reference movement with index pulse
Movement from the switching edge to the closest index pulse of the motor. The current motor position can be read via the parameter `_p_absENCusr`. The index pulse is at position value 0.

Trigger homing

Homing is triggered via bit 4=1 in parameter `DCOMcontrol`.

Status messages The drive provides information concerning positioning via Bits 10 and 12 to 15 in the parameter `DCOMstatus`.

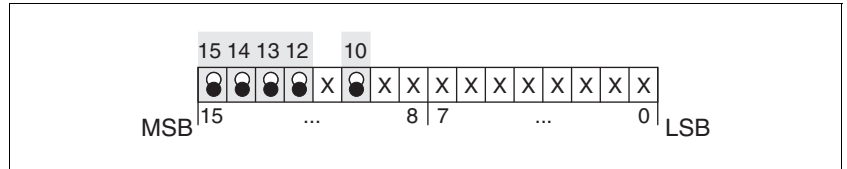

Figure 8.15 Status reports for operating mode

Parameter value	Description
Bit 10: Target reached	0: Homing not finished 1: Homing finished (even in the event of termination via "Halt")
Bit 12: Homing attained	1: Homing successfully completed
Bit 13: x_err	1: Error arisen
Bit 14: x_end	1: Homing completed, motor at a standstill
Bit 15: ref_ok	1: drive has valid reference point

8.5.5.1 Setting by parameters, general

Description There are various methods of homing which can be selected via the parameters HMmethod.

Parameter Name	Description	Unit Minimum value Default value Maximum value	Data type R/W persistent Expert	Parameter address via fieldbus
HMmethod	Homing method	-	INT16	Modbus 6936
	1: LIMN with index pulse	1	R/W	
	2: LIMP with index pulse	18	-	
	7: REF+ with index pulse, inv., outside	35	-	
	8: REF+ with index pulse, inv., inside			
	9: REF+ with index pulse, not inv., inside			
	10: REF+ with index pulse, not inv., outside			
	11: REF- with index pulse, inv., outside			
	12: REF- with index pulse, inv., inside			
	13: REF- with index pulse, not inv., inside			
	14: REF- with index pulse, not inv., outside			
	17: LIMN			
	18: LIMP			
	23: REF+, inv., outside			
	24: REF+, inv., inside			
	25: REF+, not inv., inside			
	26: REF+, not inv., outside			
	27: REF-, inv., outside			
	28: REF-, inv., inside			
	29: REF-, not inv., inside			
	30: REF-, not inv., outside			
	33: Index pulse neg. direction			
	34: Index pulse pos. direction			
	35: Position setting			
	Abbreviations: REF+: Search movement in pos. direction REF-: Search movement in pos. direction inv.: Invert direction in switch not inv.: Direction not inverted in switch outside: Index pulse / distance outside switch inside: Index pulse / distance inside switch			

Use the parameter IOsigREF to set the evaluation to active 0 or active 1 of the reference switch \overline{REF} . A release of the switch is not required.

The parameters IOsigLimP and IOsigLimN are used to release the input signals \overline{LIMP} and \overline{LIMN} and the evaluation is set to active 0 or active 1.



Use active 0 monitoring signals if possible, because they are failsafe.

Parameter Name	Description	Unit Minimum value Default value Maximum value	Data type R/W persistent Expert	Parameter address via fieldbus
IOsigRef	Signal evaluation REF	-	UINT16 R/W per. -	Modbus 1564
	1 / normally closed: Normally closed NC 2 / normally open: Normally open NO	1 1 2		
The reference switch is only activated (to REF) while homing is processed.				
IOsigLimN	Signal evaluation LIMN	-	UINT16 R/W per. -	Modbus 1566
	0 / inactive: Inactive 1 / normally closed: Normally closed NC 2 / normally open: Normally open NO	0 1 2		
IOsigLimP	Signal evaluation LIMP	-	UINT16 R/W per. -	Modbus 1568
	0 / inactive: Inactive 1 / normally closed: Normally closed NC 2 / normally open: Normally open NO	0 1 2		

The parameters HM_n and HM_n_out are used for setting the speeds for the reference movement.

Parameter Name	Description	Unit Minimum value Default value Maximum value	Data type R/W persistent Expert	Parameter address via fieldbus
HMn	Speed of rotation for search of switch	min^{-1}	UINT16 R/W per. -	Modbus 10248
	The adjustable value is internally limited to the current parameter setting in $RAMP_n_max$.	1 60 13200		
HMn_out	Speed of rotation for moving away from switch	min^{-1}	UINT16 R/W per. -	Modbus 10250
	The adjustable value is internally limited to the current parameter setting in $RAMP_n_max$.	1 6 3000		

The parameter $HMp_homeusr$ can be used to specify a desired position value, which is set at the reference point after a successful reference movement. This position value defines the current motor position at the reference point. This also defines the zero point.

Parameter Name	Description	Unit Minimum value Default value Maximum value	Data type R/W persistent Expert	Parameter address via fieldbus
HMp_homeusr	Position at reference point	usr	INT32 R/W per. -	Modbus 10262
	After a successful reference movement, this position is automatically set at the reference point.	-2147483648 0 2147483647		

The parameters $HMoutdisusr$ and $HMSrchdisusr$ can be used for activation of the monitoring of the switch function.

019844113652, V2.00, 11.2008

Parameter Name	Description	Unit Minimum value Default value Maximum value	Data type R/W persistent Expert	Parameter address via fieldbus
HMoutdisusr	<p>Maximum distance for search for switching edge</p> <p>0: Monitoring of distance inactive >0: Maximum distance in user-defined units</p> <p>After detection of the switch, the drive starts to search for the defined switching edge. If it is not found within the distance defined here, the reference movement is canceled with an error.</p>	usr 0 0 2147483647	INT32 R/W per. -	Modbus 10252
HMrchdisusr	<p>Max. search distance after overrun of switch</p> <p>0: Search distance processing disabled >0: Search distance in user units</p> <p>The switch must be activated again within this search distance, otherwise the reference movement is canceled.</p>	usr 0 0 2147483647	INT32 R/W per. -	Modbus 10266

8.5.5.2 Reference movement without index pulse

Description A reference movement without index pulse is set with the parameter HMmethod = 17 to 30, see page 140.

First, the product moves to the defined limit switch or reference switch. Then the product moves to a defined distance from the switching edge.

The distance from the switching edge can be specified with the parameter HMdisusr.

Parameter Name	Description	Unit Minimum value Default value Maximum value	Data type R/W persistent Expert	Parameter address via fieldbus
HMdisusr	Distance from switching edge to reference point After the drive 'leaves' the switch, it is positioned into the working area by a defined distance. This target point is defined as the reference point. The parameter is only effective during reference movements without index pulse search.	usr 1 200 2147483647	INT32 R/W per. -	Modbus 10254

Reference movement to limit switch The following illustration shows a reference movement to the negative limit switch with distance from the switching edge (HMmethod = 17).

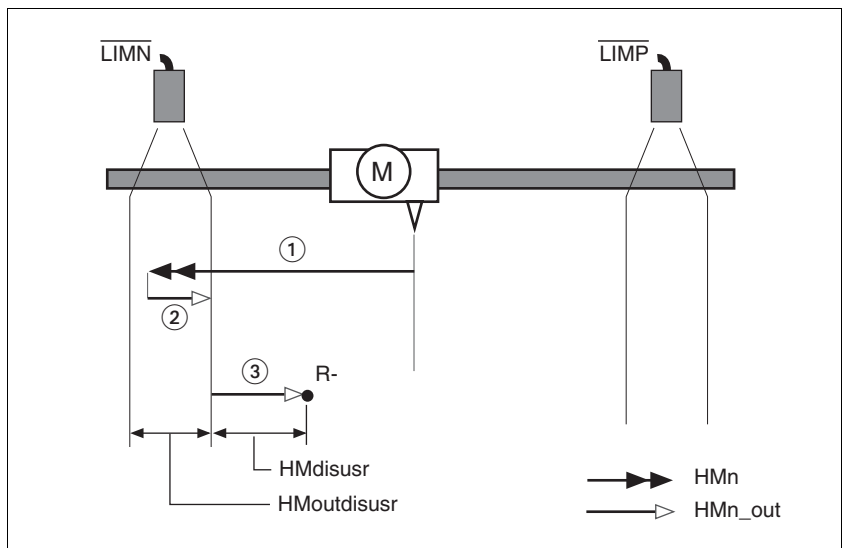

Figure 8.16 Reference movement to the negative limit switch

- (1) Movement to limit switch at search speed
- (2) Movement to switching edge at speed for moving away from switch
- (3) Movement to distance from switching edge at speed for moving away from switch

019844113652, V2.00, 11.2008

Reference movement to reference switch

The following illustration shows reference movements to the reference switch with distance from the switching edge (HMmethod =27 to 30).

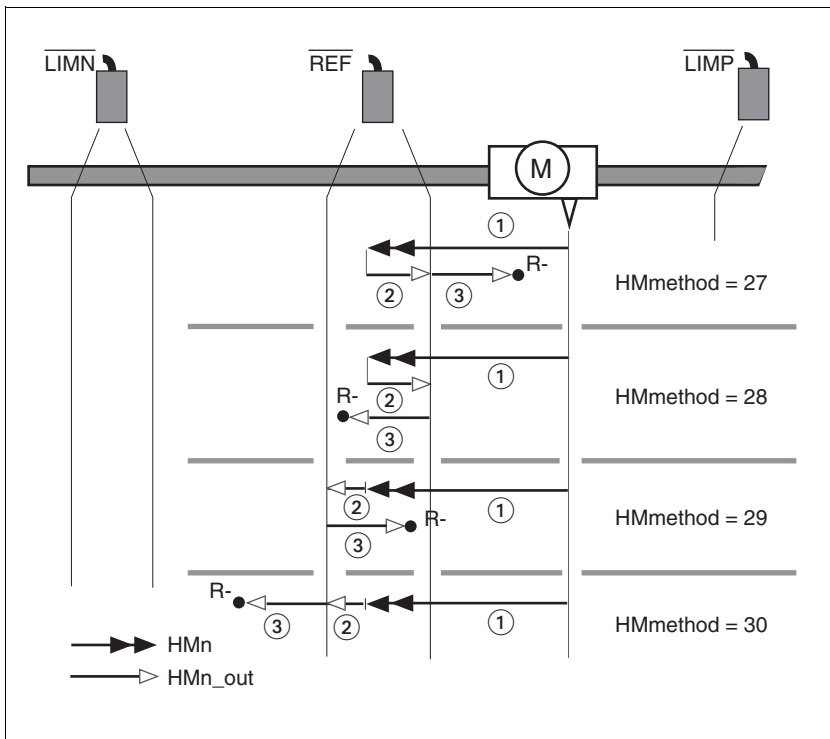

Figure 8.17 Reference movements to the reference switch

- (1) Movement to reference switch at search speed
- (2) Movement to switching edge at speed for moving away from switch
- (3) Movement to distance from switching edge at speed for moving away from switch

Examples The following illustration shows reference movements to the reference switch with distance from the switching edge ($HM_{method}=27$). You can see different responses at different search speeds and start positions.

- Movement to the reference switch with first movement in negative direction; the reference switch is once in front of the starting point (A1, A2), once behind it (B1, B2).
- Additional movement when the unit moves through the switch range (A2, B2).

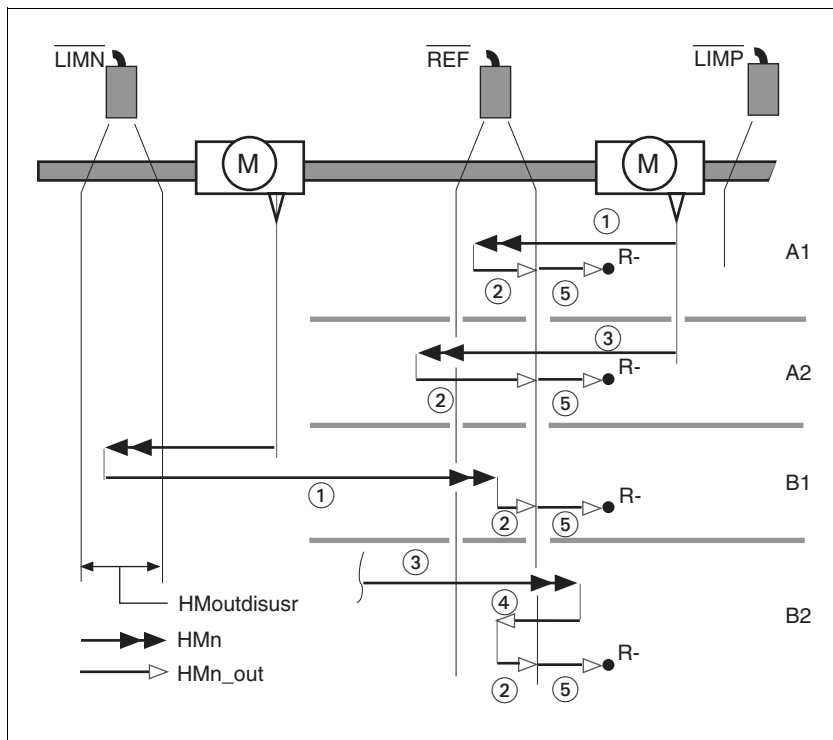

Figure 8.18 Reference movements to the reference switch

- (1) Movement to reference switch at search speed
- (2) Movement to switching edge at speed for moving away from switch
- (3) Excessively fast movement to reference switch at search speed
- (4) Return movement to switch range at speed for moving away from switch
- (5) Movement to distance from switching edge at speed for moving away from switch

8.5.5.3 Reference movement with index pulse

Description A reference movement with index pulse is set with the parameter `HMmethod = 1 to 14`, see page 140.

First, the product moves to the defined limit switch or reference switch. Then the product moves to the nearest index pulse.

Parameterization The position distance between the switching edge and index pulse can be determined with the parameter `HMdisREFtoIDX`.

The value should be >0.05 .

This way, the reference movement with index pulse is reproducible.

If the index pulse is too close to the switching edge, the limit switch or reference switch can be moved mechanically.

Otherwise the position of the index pulse can be moved with the parameter `ENC_pabsusr`, see Chapter 7.2.13 "Setting parameters for encoder".

Parameter Name	Description	Unit Minimum value Default value Maximum value	Data type R/W persistent Expert	Parameter address via fieldbus
HMdisREFtoIDX	Distance from switching edge to index pulse This read value delivers the difference between the index pulse position and the position at the switching edge of the limit or reference switch. It allows to check the distance between the index pulse and the switching edge and serves as a criterion for determining whether the reference movement with index pulse processing can be reproduced. In increments of 1/10000 revolutions	revolution - 0.0000 -	INT32 R/- - -	Modbus 10264

Reference movement to limit switch The following illustration shows a reference movement to the positive limit switch with movement to the first index pulse (`HMmethod = 2`).

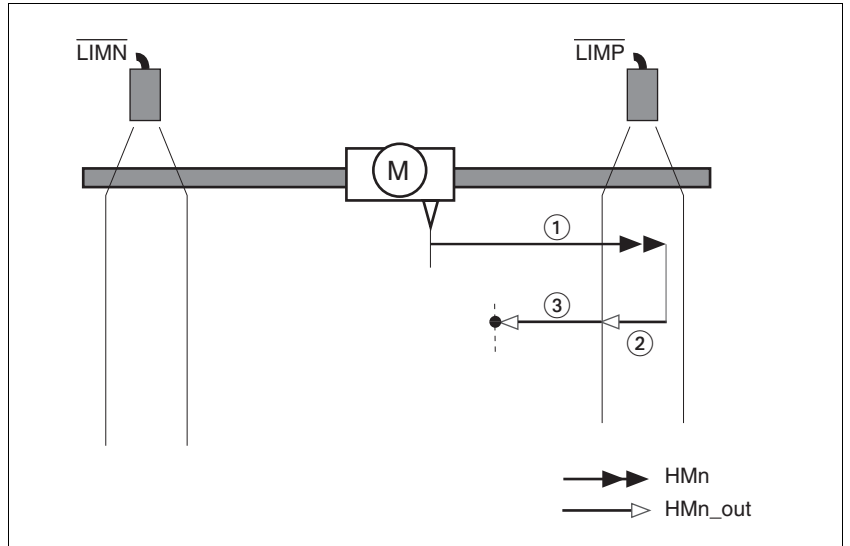

Figure 8.19 Reference movement to the positive limit switch

- (1) Movement to limit switch at search speed
- (2) Movement to switching edge at speed for moving away from switch
- (3) Movement to index pulse at speed for moving away from switch

Reference movement to reference switch

The following illustration shows reference movements to the reference switch with movement to the first index pulse (HMmethod = 11 to 14).

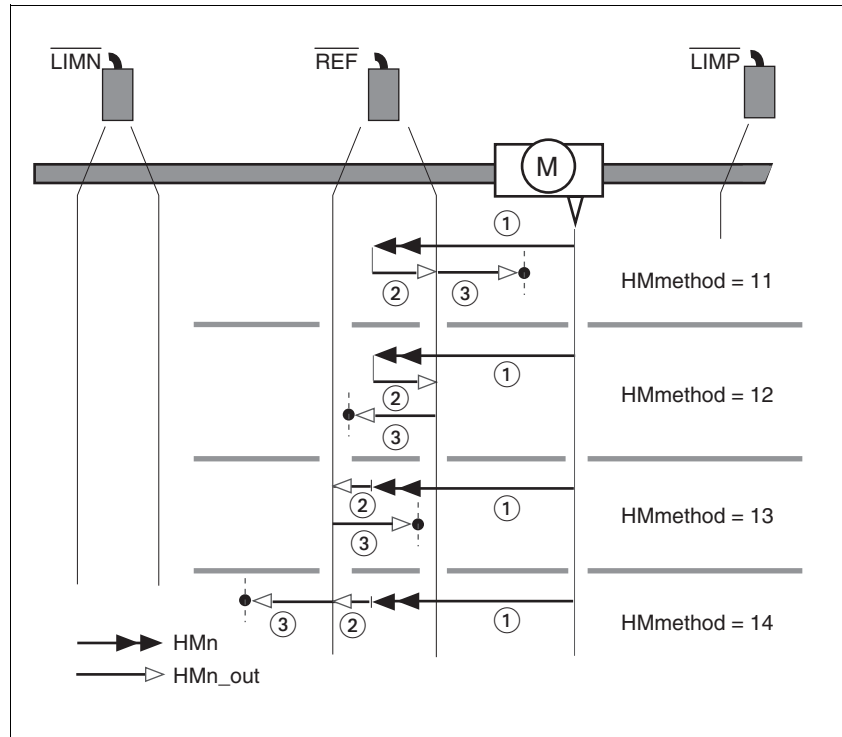

Figure 8.20 Reference movements to the reference switch

- (1) Movement to reference switch at search speed
- (2) Movement to switching edge at speed for moving away from switch
- (3) Movement to index pulse at speed for moving away from switch

Examples The following illustration shows reference movements to the reference switch with movement to the first index pulse (HMmethod = 11). Various responses at different search speeds and start positions are shown.

- Movement to the reference switch with first movement in negative direction; the reference switch is once in front of the starting point (A1, A2), once behind it (B1, B2).
- Additional movement when the unit moves through the switch range (A2, B2).

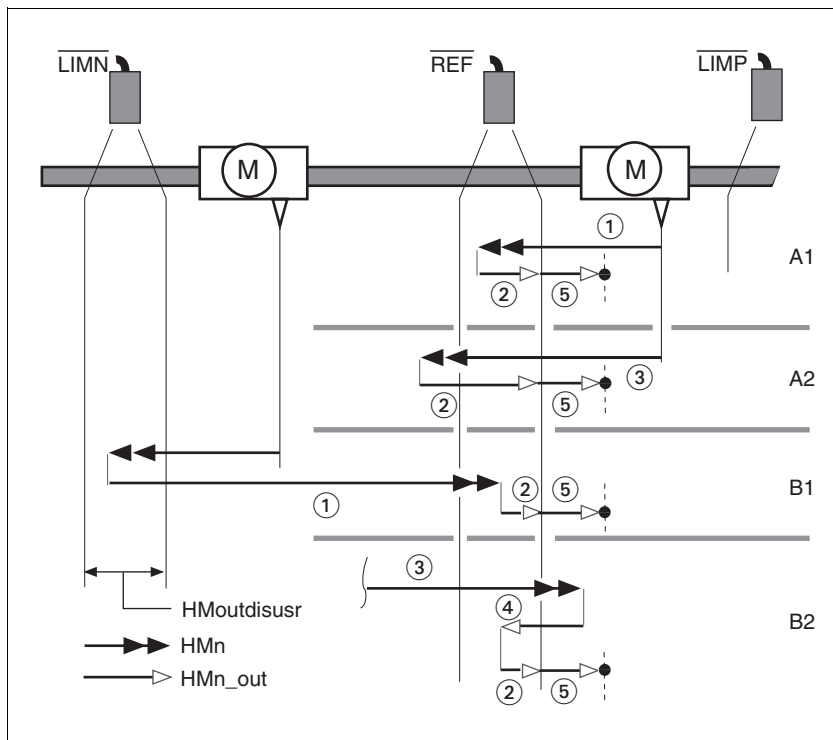

Figure 8.21 Reference movements to the reference switch

- (1) Movement to reference switch at search speed
- (2) Movement to switching edge at speed for moving away from switch
- (3) Excessively fast movement to reference switch at search speed
- (4) Return movement to switch range at speed for moving away from switch
- (5) Movement to index pulse at speed for moving away from switch

8.5.5.4 Reference movement to the index pulse

Description The motor moves from the current motor position to the index pulse.

Reference movement to index pulse The following illustration shows reference movements to the index pulse (HMmethod = 33 and 34).

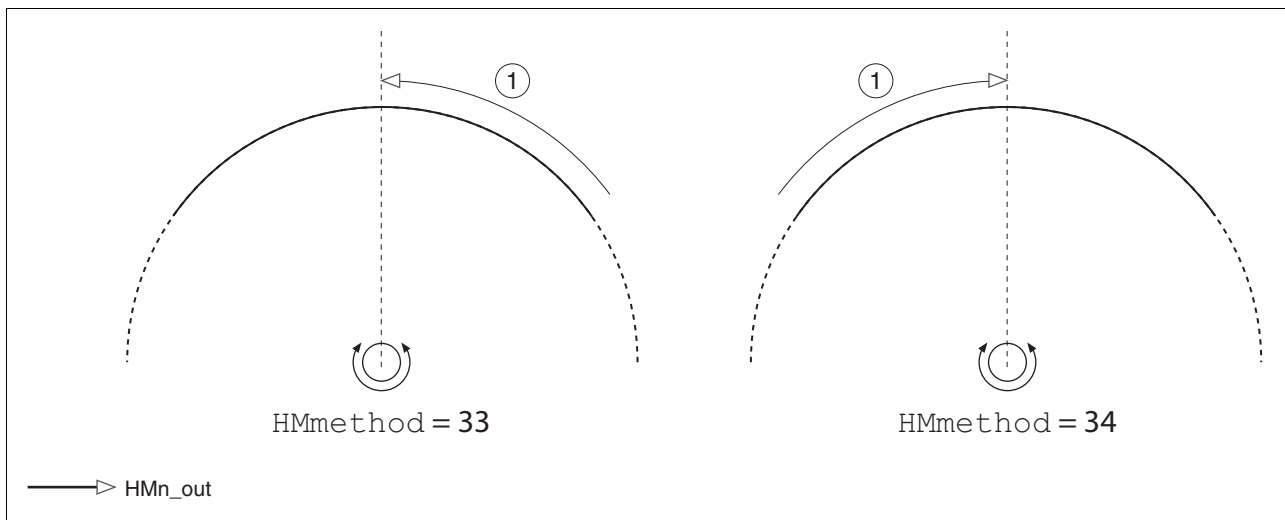

Figure 8.22 Reference movements to the index pulse

- (1) Movement to index pulse at speed for moving away from switch

8.5.5.5 Homing by position setting

Description Homing by position setting is set with the parameter `HMmethod = 35`, see page 140.

By means of position setting, the current motor position is set to the position value in parameter `HMp_setpusr`. This also defines the zero point.

Homing by position setting can only be carried out when the motor is at a standstill. Any active position deviation is retained and can still be compensated by the position controller after position setting.

Parameter Name	Description	Unit	Data type	Parameter address via fieldbus
		Minimum value	R/W	
		Default value	persistent	
		Maximum value	Expert	
HMp_setpusr	Position for position setting	usr	INT32	Modbus 6956
	Position setting position for homing method 35	-	R/W	
		0	-	
		-	-	

Example Position setting can be used to carry out a continuous motor movement without exceeding the positioning limits.

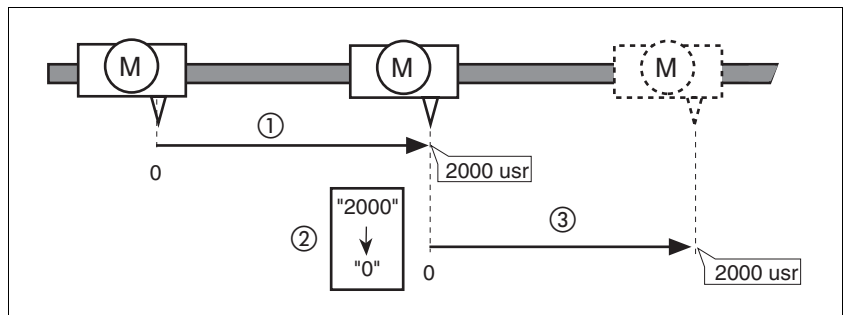

Figure 8.23 Positioning by 4000 usr units with position setting

- (1) The motor is positioned by 2000 usr.
- (2) By means of position setting to 0, the current motor position is set to position value 0 which, at the same time, defines a new zero point.
- (3) When a new motion command by 2000 usr is triggered, the new target position is 2000 usr.

This method avoids overtravel of the absolute position limits during a positioning operation because the zero point is continuously adjusted.

The reference position is read by means of parameter `_p_refusr`.

Parameter Name	Description	Unit	Data type	Parameter address via fieldbus
		Minimum value	R/W	
		Default value	persistent	
		Maximum value	Expert	
_p_refusr	Reference position in user units	usr	INT32	Modbus 7704
	Value corresponds to the reference position of the position controller.	-	R/-	
		0	-	
		-	-	

019844113652, V2.00, 11.2008

8.6 Functions

8.6.1 Monitoring functions

8.6.1.1 Status monitoring during operation

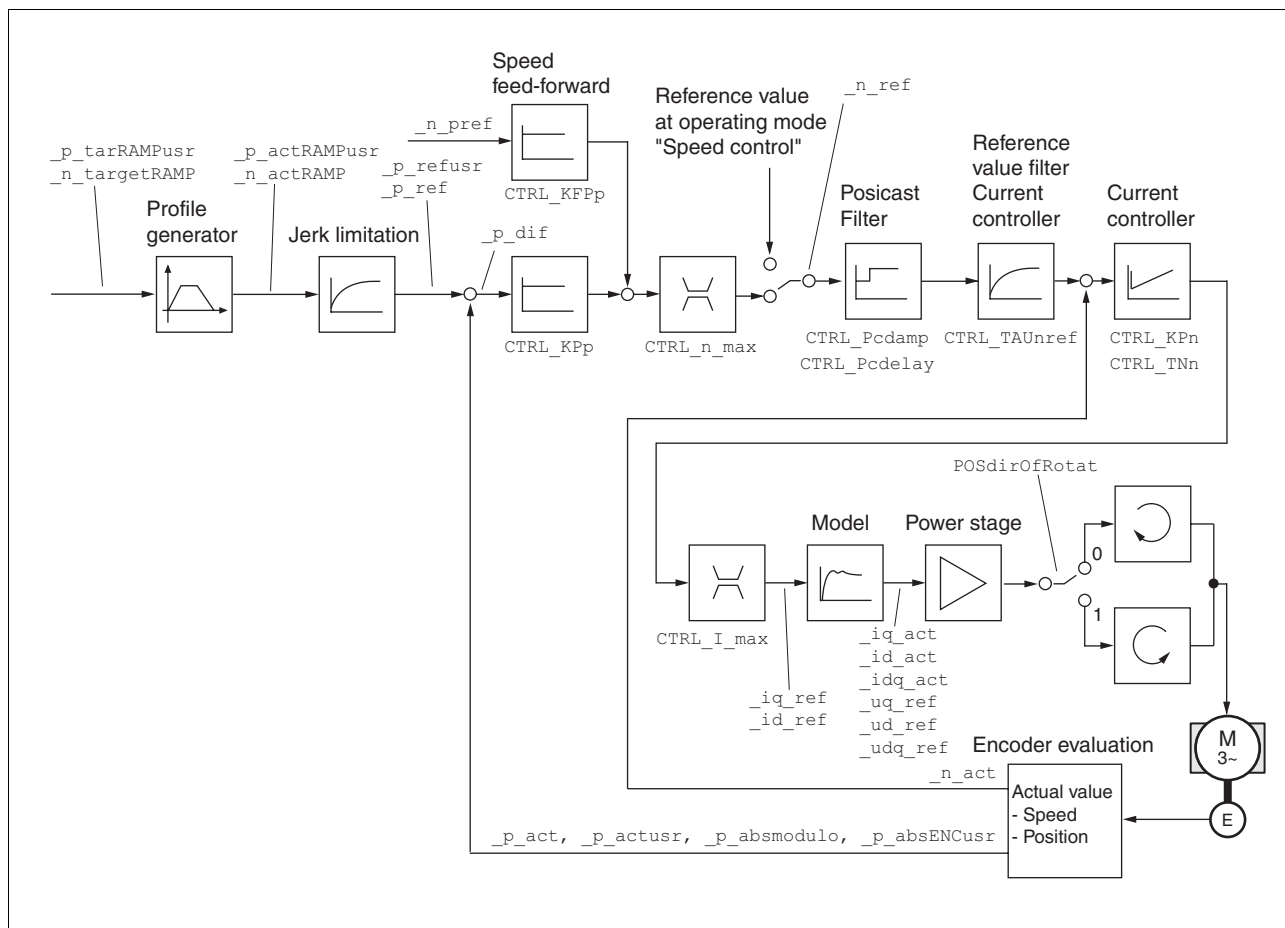

Figure 8.24 Status monitoring of the control loops

8.6.1.2 Positioning range

Positioning range The motor can be moved to any point on the axis within the positioning range by means of absolute positioning.

The current position of the motor can be read with the parameter `_p_actusr`.

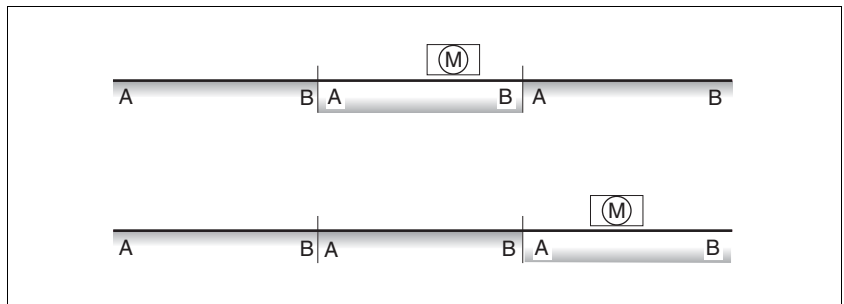

Figure 8.25 Positioning range

With the default scaling, the positioning limits are:

- (A) -1073741824 usr
- (B) 1073741823 usr

Overtraveling of the positioning limits is possible in all operating modes, except during absolute positioning in Profile Position operating mode.

If the motor overtravels the positioning limit, the reference point is lost.

In the case of relative positioning in the operating mode Profile Position, the unit checks whether the position limits will be overtraveled before the movement is started. If so, internal position setting to 0 is triggered when the movement is started. The reference point is lost (`ref_ok = 1 -> 0`).

Software limit switches The positioning range can be limited by software limit switches. This is possible as soon as the drive has a valid zero point (`ref_ok = 1`). The position values are specified with reference to the zero point. The software limit switches are set via the parameters `SPVswLimPusr` and `SPVswLimNusr` are activated via `SPV_SW_Limits`. Bit 2 of parameter `_SigLatched` signals the triggering of a software limit switch.

The determining factor for position monitoring of the software limit switch range is the reference position of the position controller. Therefore, depending on the controller settings, the motor may stop before it reaches the limit switch position.

Parameter Name	Description	Unit Minimum value Default value Maximum value	Data type R/W persistent Expert	Parameter address via fieldbus
SPVswLimPusr	Positive position limit for software limit switch If a user value entered is outside of the permissible user range, the limit switch limits are automatically set to the max. user value.	usr - 2147483647 -	INT32 R/W per. -	Modbus 1544
SPVswLimNusr	Negative position limit for software limit switch Refer to description 'SPVswLimPusr'	usr - -2147483648 -	INT32 R/W per. -	Modbus 1546

019844113652, V2.00, 11.2008

Parameter Name	Description	Unit Minimum value Default value Maximum value	Data type R/W persistent Expert	Parameter address via fieldbus
SPV_SW_Limits	<p>Monitoring of software limit switches</p> <p>0 / none: None (default) 1 / SWLIMP: Activation of software limit switches positive direction 2 / SWLIMN: Activation of software limit switches negative direction 3 / SWLIMP+SWLIMN: Activation of software limit switches both directions</p> <p>Monitoring of software limit switches only works in case of successful homing (ref_ok = 1).</p>	- 0 0 3	UINT16 R/W per. -	Modbus 1542

Limit switches

⚠ WARNING

LOSS OF CONTROL

The use of $\overline{\text{LIMP}}$ and $\overline{\text{LIMN}}$ can provide some protection against hazards (e.g. collision with mechanical stop caused by incorrect reference values).

- Use $\overline{\text{LIMP}}$ and $\overline{\text{LIMN}}$ where possible.
- Verify that the external sensors or switches are properly connected.
- Verify the correct of the limit switches. The limit switches must be mounted in a position far enough away from the mechanical stop to allow for an adequate stopping distance.
- Before you can use $\overline{\text{LIMP}}$ and $\overline{\text{LIMN}}$, you must enable them.

Failure to follow these instructions can result in death, serious injury or equipment damage.

During movements the two limit switches are monitored via the input signals $\overline{\text{LIMP}}$ and $\overline{\text{LIMN}}$. If the drive hits a limit switch, the motor stops. Triggering of the limit switch is signaled.

The parameters IOsigLimP and IOsigLimN are used to release the input signals $\overline{\text{LIMP}}$ and $\overline{\text{LIMN}}$ and the evaluation is set to active 0 or active 1.



Use active 0 monitoring signals if possible, because they are failsafe.

Parameter Name	Description	Unit Minimum value Default value Maximum value	Data type R/W persistent Expert	Parameter address via fieldbus
IOsigLimN	<p>Signal evaluation LIMN</p> <p>0 / inactive: Inactive 1 / normally closed: Normally closed NC 2 / normally open: Normally open NO</p>	- 0 1 2	UINT16 R/W per. -	Modbus 1566

Parameter Name	Description	Unit Minimum value Default value Maximum value	Data type R/W persistent Expert	Parameter address via fieldbus
IOsigLimP	Signal evaluation LIMP 0 / inactive: Inactive 1 / normally closed: Normally closed NC 2 / normally open: Normally open NO	- 0 1 2	UINT16 R/W per. -	Modbus 1568
IOsigRef	Signal evaluation REF 1 / normally closed: Normally closed NC 2 / normally open: Normally open NO	- 1 1 2	UINT16 R/W per. -	Modbus 1564

The reference switch is only activated (to REF) while homing is processed.

Moving drive out The drive can be moved away from the limit switch range to the movement range in the Jog operating mode.

8.6.1.3 Monitoring internal signals

Temperature monitoring Sensors monitor the temperature of motor and power stage. All temperature limit values are permanently set. If the temperature of a component approaches its permissible temperature limit, the device generates a warning message. If the temperature exceeds the limit value for more than 5 seconds, the power stage is disabled and the controller switches off. The device signals a temperature error.

Parameter Name	Description	Unit Minimum value Default value Maximum value	Data type R/W persistent Expert	Parameter address via fieldbus
_Temp_act_PA	Power stage temperature	°C - 0 -	INT16 R/- - -	Modbus 7200
PA_T_max	Maximum permissible power stage temperature	°C - 0 -	INT16 R/- per. -	Modbus 4110
PA_T_warn	Temperature warning threshold of power stage	°C - 0 -	INT16 R/- per. -	Modbus 4108

I²t monitoring If the device operates with high peak currents, temperature monitoring with sensors can be too sluggish. I²t monitoring allows the controller to anticipate a rise in temperature and to reduce the current to the nominal value when the I²t limit value is exceeded.

When the value falls below the limit value, the device can be operated with maximum performance again.

019844113652, V2.00, 11.2008

Parameter Name	Description	Unit Minimum value Default value Maximum value	Data type R/W persistent Expert	Parameter address via fieldbus
_l2t_act_M	Current motor overload	% - 0 -	INT16 R/- - -	Modbus 7218
_l2t_mean_M	Motor load	% - 0 -	INT16 R/- - -	Modbus 7220

Tracking error monitoring The drive monitors the so-called position deviation at 1 ms intervals. The position deviation is the difference between the current reference position and the actual position. If the value of this position difference exceeds the limit value set in parameter `SPV_P_maxDiff`, this will cause an immediate stop (tracking error) with an error class that can be parameterized.

Select the limit value in parameter `SPV_P_maxDiff` considerably greater than the maximum position deviation that may occur during normal operation. This way, a tracking error will only occur in case of errors, for example, in the case of excessively high external load torques or in-operative encoder.

The maximum control deviation that occurred during operation can be determined with the parameter `_p_DifPeak`; it can be compared to the maximum permissible position deviation. This allows you to determine how far away the product was from the shut-off limit.

In addition, you can change the error class for a tracking error, see also chapter 8.6.1 "Monitoring functions".

Parameter Name	Description	Unit Minimum value Default value Maximum value	Data type R/W persistent Expert	Parameter address via fieldbus
_p_DifPeak	Value of the maximum tracking error of the position controller The tracking error is the current position control deviation. See <code>SPV_p_maxDiff</code> for more information. A write access resets this value.	revolution 0.0000 - 429496.7295	UINT32 R/W - -	Modbus 4382
_p_dif	Current deviation between reference and actual position Corresponds to the current control deviation of the position controller.	revolution -214748.3648 - 214748.3647	INT32 R/- - -	Modbus 7716
SPV_p_maxDiff	Max. permissible tracking error of the position controller The tracking error is the current position control deviation.	revolution 0.0001 1.0000 200.0000	UINT32 R/W per. -	Modbus 4636

Monitoring parameters The device status and operating state can be monitored by means of various objects.

Parameter Name	Description	Unit Minimum value Default value Maximum value	Data type R/W persistent Expert	Parameter address via fieldbus
_SigActive	Current status of monitoring signals	-	UINT32	Modbus 7182
	See _SigLatched for more details on the bit codes.	- 0 -	R/ - -	
_SigLatched	Saved status of monitoring signals	-	UINT32	Modbus 7184
	Signal status: 0: Not activated 1: Activated	- 0 -	R/ - -	
	Bit assignments: Bit 0: General fault Bit 1: Limit switches (LIMP/LIMN/REF) Bit 2: Out of range (SW limit switches, tuning) Bit 3: Quickstop via fieldbus Bit 4: Inputs STO are 0 Bit 5: Reserved Bit 6: RS485 fault Bit 7: CAN fault Bit 8: Ethernet fault Bit 9: Frequency of reference signal too high Bit 10: Fault current operating mode Bit 11: Reserved Bit 12: Profibus fault Bit 13: Reserved Bit 14: Undervoltage DC bus Bit 15: Overvoltage DC bus Bit 16: Mains phase missing Bit 17: Motor connection fault Bit 18: Motor overcurrent/short circuit Bit 19: Motor encoder fault Bit 20: Undervoltage 24VDC Bit 21: Overtemperature (power stage, motor) Bit 22: Tracking error Bit 23: Max. speed exceeded Bit 24: Inputs STO different Bit 25: Reserved Bit 26: Reserved Bit 27: Reserved Bit 28: Reserved Bit 29: EEPROM fault Bit 30: System booting (Hardware fault or parameter error) Bit 31: System error (e.g. watchdog)			
	Monitoring functions are product-dependent.			
_WarnActive	Active warnings, bit-coded	-	UINT16	Modbus 7190
	See _WarnLatched for more details on the bit codes.	- 0 -	R/ - -	

019844113652, V2.00, 11.2008

Parameter Name	Description	Unit Minimum value Default value Maximum value	Data type R/W persistent Expert	Parameter address via fieldbus
_WarnLatched	<p>Saved warnings, bit-coded</p> <p>Saved warning bits are deleted in the case of a FaultReset. Bits 10, 11, 13 are deleted automatically.</p> <p>Signal status: 0: Not activated 1: Activated</p> <p>Bit assignments: Bit 0: General warning (see _LastWarning) Bit 1: Temperature of power stage high Bit 2: Temperature of motor high Bit 3: Reserved Bit 4: Power stage overload (I^2t) Bit 5: Motor overload (I^2t) Bit 6: Braking resistor overload (I^2t) Bit 7: CAN warning Bit 8: Motor encoder warning Bit 9: RS485 protocol warning Bit 10: STO_A (PWRR_A) and/or STO_B (PWRR_B) Bit 11: DC bus undervoltage/missing mains phase Bit 12: Profibus warning Bit 13: Position not yet valid (position capture still running) Bit 14: Ethernet warning Bit 15: Reserved</p> <p>Monitoring functions are product-dependent.</p>	- - 0 -	UINT16 R/- - -	Modbus 7192
_actionStatus	<p>Action word</p> <p>Signal status: 0: not activated 1: activated</p> <p>Bit 0: Warning Bit 1: Error class 1 Bit 2: Error class 2 Bit 3: Error class 3 Bit 4: Error class 4 Bit 5: Reserved Bit 6: Drive is at standstill (<9 [1/min]) Bit 7: Drive rotates clockwise Bit 8: Drive rotates counter-clockwise Bit 9: Reserved Bit 10: Reserved Bit 11: Profile generator idle (reference speed is 0) Bit 12: Profile generator decelerates Bit 13: Profile generator accelerates Bit 14: Profile generator moves at constant speed Bit 15: Reserved</p>	- - 0 -	UINT16 R/- - -	Modbus 7176
_StopFault	Error number of last stop fault	- - 0 -	UINT16 R/- - -	Modbus 7178

Setting error responses The responses of the device to errors are subdivided into error classes; the error class can be set for a number of monitoring functions. This allows you to tune the error response of the device to operation requirements.

Parameter Name	Description	Unit Minimum value Default value Maximum value	Data type R/W persistent Expert	Parameter address via fieldbus
SPV_Flt_pDiff	Error response to tracking error 1 / ErrorClass1: Error class 1 2 / ErrorClass2: Error class 2 3 / ErrorClass3: Error class 3	- 1 3 3	UINT16 R/W per. -	Modbus 1302

8.6.2 Scaling

⚠ WARNING**UNEXPECTED MOVEMENT CAUSED BY CHANGED SCALING**

Changing the scaling changes the effect of the values in user-defined units. The same motion commands can therefore cause different movements.

- Note that the scaling affects all relationships between the set values and the movements of the drive.
- Check the corresponding usr parameters and values of the system in user-defined units.

Failure to follow these instructions can result in death, serious injury or equipment damage.

Description Scaling translates user units to internal units of the device, and vice versa. The device saves position values in user-defined units.

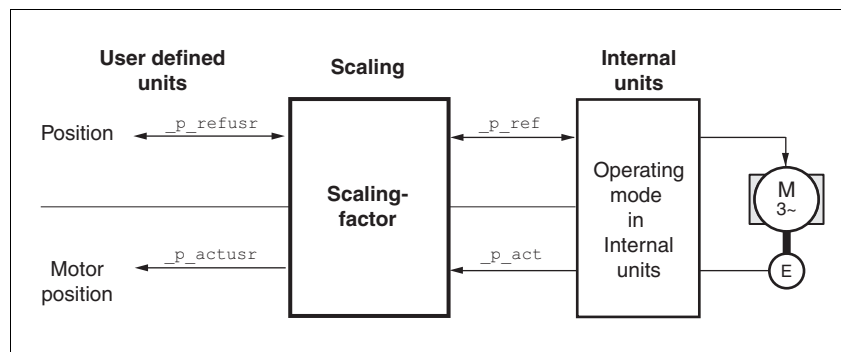

Figure 8.26 Scaling

Scaling factor The scaling factor is the relationship between the number of motor revolutions and the required user-defined units [usr].

$$\text{Scaling factor} = \frac{\text{Motor revolutions}}{\text{Change of the user position [usr]}}$$

Figure 8.27 Representation of the scaling factor

The scaling factor is set using the parameters POSscaleNum and POSscaleDenom. A new scaling factor is activated when you specify the numerator value.

When specifying the scaling factor, note that numerator and denominator can only be integer values. A scaling factor less than 1/131072 will limit the working range. An error is signaled when the working range is exceeded.

The scaling factor can only be changed when the power stage is disabled. Values in user-defined units are converted to internal units when the power stage is enabled.

Parameter Name	Description	Unit Minimum value Default value Maximum value	Data type R/W persistent Expert	Parameter address via fieldbus
POSScaleNum	Numerator of position scaling Specification of the scaling factor: Motor revolutions [U] ----- Change of user position [usr] A new scaling is activated when the numerator value is supplied. User limit values may be reduced due to the calculation of an internal factor.	revolution 1 1 2147483647	INT32 R/W per. -	Modbus 1552
POSScaleDenom	Denominator of position scaling Refer to numerator (POSScaleNum) for a description. A new scaling is activated when the numerator value is supplied.	usr 1 16384 2147483647	INT32 R/W per. -	Modbus 1550



If an existing device is replaced by this device, and if the same positioning commands are to be used, the scaling must be set in accordance with the settings used previously.

Default scaling

A value of 16384 user-defined units per motor revolution is set as the default scaling.

Examples

Various situations can be distinguished as far as setting user-defined units is concerned.

- Scaling corresponds to default scaling
1 motor revolution = 16384 user-defined units
=> Every second motor position can be approached.
- Scaling corresponds to motor resolution (minimum scaling)
1 motor revolution = 32768 user-defined units
=> Every motor position can be approached.
- Scaling is less than the default scaling
1 motor revolution = 4096 user-defined units
=> Every fourth motor position can be approached.

The following persistent parameters must be adapted in addition to the user-defined values to obtain the same positioning movement of the motor after changing the scaling factor: HMoutdisusr, HMdisusr, HMp_homeusr, HMsrchdisusr, JOGstepusr, SPVswLimPusr and SPVswLimNusr.

019844113652, V2.00, 11.2008

Example 1 Positioning by 1111 user-defined units is to correspond to 3 motor revolutions. This results in

$$\text{Scaling factor} = \frac{3 \text{ rev}}{1111 \text{ usr}}$$

Figure 8.28 Calculation of the scaling factor, example 1

If you now start relative positioning by 900 user-defined units, the motor moves by $900 \text{ usr} * 3/1111 \text{ rev/usr} = 2.4302$ revolutions.

Example 2 Calculation of a scaling factor in length units: 1 motor revolution corresponds to a distance of 100 mm. Each user-defined unit [usr] is to correspond to one step of 0.01 mm.

This means: $1 \text{ usr} = 0.01 \text{ mm} * 1 \text{ rev} / 100 \text{ mm} = 1/10000$ revolutions.

$$\text{Scaling factor} = \frac{1 \text{ rev}}{10000 \text{ usr}}$$

Figure 8.29 Calculation of the scaling factor, example 2

Example 3 Setting positioning in $1/1000$ rad

$$1 \text{ rad} = 1 \text{ rev} / (2 * \pi)$$

$$\pi = 3.1416 \text{ (rounded)}$$

$$\text{User value} = 1 \text{ usr}$$

$$\text{Device value} = 1 / (2 * \pi * 1000) \text{ U}$$

$$\text{Scaling factor} = \frac{1 \text{ rev}}{2 * 3,1416 * 1000 \text{ usr}} = \frac{1 \text{ rev}}{6283,2 \text{ usr}} = \frac{10 \text{ rev}}{62832 \text{ usr}}$$

Figure 8.30 Calculation of the scaling factor, example 3

8.6.3 Motion profile

Profile generator Target position and target speed of rotation are input values to be specified by the user. The profile generator uses these values to calculate a motion profile depending on the selected operating mode.

The values of the profile generator plus the values of a jerk limitation are transformed into a motor movement.

The acceleration and deceleration behavior of the motor can be described as a ramp function of the profile generator. The characteristic values of the ramp function are the ramp shape and the ramp steepness.

Ramp shape A linear ramp for the acceleration and deceleration phases is available as the ramp shape. The profile settings are valid for both directions of movement of the drive.

Ramp steepness The steepness of the ramp determines the speed changes of the motor per time unit. The ramp steepness can be set for the acceleration ramp via the parameter RAMPacc and for the deceleration ramp via RAMPdecel.

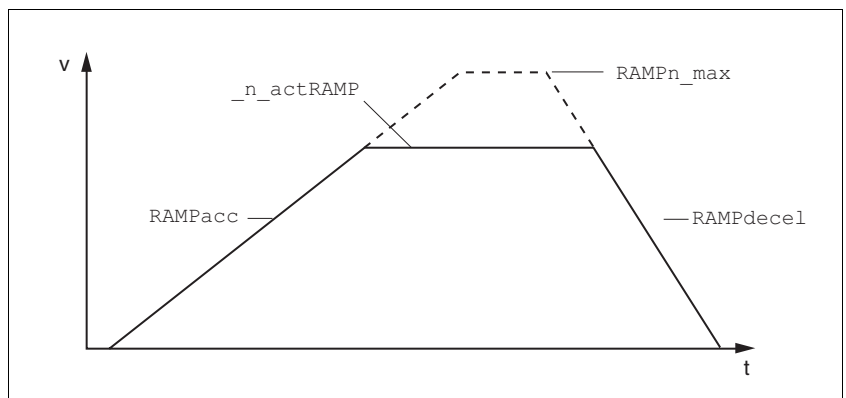

Figure 8.31 Acceleration and deceleration ramps

Parameter Name	Description	Unit Minimum value Default value Maximum value	Data type R/W persistent Expert	Parameter address via fieldbus
RAMPacc	Acceleration of profile generator	min ⁻¹ /s 1 600 3000000	UINT32 R/W per. -	Modbus 1556
RAMPdecel	Deceleration of profile generator	min ⁻¹ /s 750 750 3000000	UINT32 R/W per. -	Modbus 1558

019844113652, V2.00, 11.2008

Parameter Name	Description	Unit Minimum value Default value Maximum value	Data type R/W persistent Expert	Parameter address via fieldbus
RAMPn_max	<p>Limitation of ref. speed for op. modes with profile generation</p> <p>The parameter is active in the following operating modes:</p> <ul style="list-style-type: none"> - Profile position - Profile velocity - Homing - Jog <p>If a greater reference speed is set in one of these operating modes, it is automatically limited to RAMPn_max.</p> <p>This way, commissioning at limited speed is easy to perform.</p>	min ⁻¹ 60 13200 13200	UINT16 R/W per. -	Modbus 1554

Jerk limitation Jerk limitation removes sudden changes in the acceleration to obtain smooth, virtually jerk-free changes of the speed of rotation.

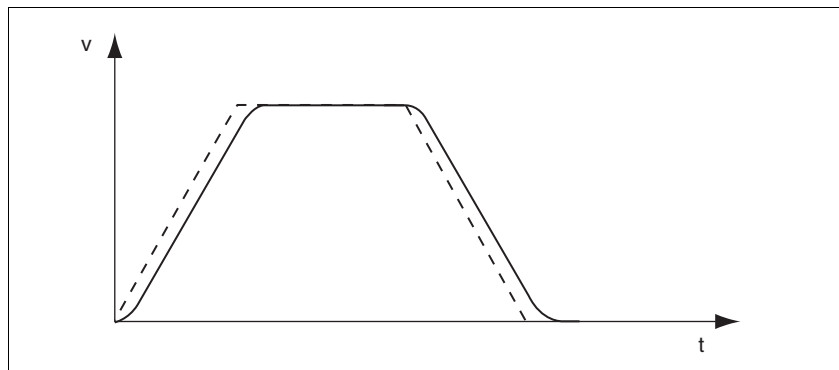

Figure 8.32 Speed curve with and without (dotted) jerk limitation

The jerk limitation is activated and adjusted via the parameter RAMP_TAUjerk.

The end of the movement ($x_{end} = 1$) is not signaled until the target position at the end of the jerk limitation has been reached.

Parameter Name	Description	Unit Minimum value Default value Maximum value	Data type R/W persistent Expert	Parameter address via fieldbus
RAMP_TAUjerk	<p>Jerk limitation</p> <p>0 / off: Off 1 / 1: 1 ms 2 / 2: 2 ms 4 / 4: 4 ms 8 / 8: 8 ms 16 / 16: 16 ms 32 / 32: 32 ms 64 / 64: 64 ms 128 / 128: 128 ms</p> <p>Limits the acceleration change (jerk) of the reference position generation during the positioning transitions: Standstill - acceleration Acceleration - constant speed Constant speed - deceleration Deceleration - standstill</p> <p>Processing in the following operating modes: - Profile velocity - Profile position - Jog - Homing</p> <p>Adjustments can only be made if the operating mode is inactive (x_end=1).</p>	ms 0 0 128	UINT16 R/W per. -	Modbus 1562

019844113652, V2.00, 11.2008

8.6.4 Quick Stop

- Function principle* "Quick Stop" is a quick brake function which stops the motor as a result of an error of error classes 1 and 2 or as a result of a software stop.
- In the event of an error response to an error of error class 1, the power stage remains enabled. In the case of error class 2, the power stage is disabled after the drive has come to a standstill.
- The motor can be decelerated via a deceleration ramp or a maximum current. Use the parameter LIM_QStopReact to set the type of deceleration.
- ▶ Set the type of deceleration with the LIM_QStopReact parameter.
 - ▶ Use parameter RAMPquickstop to define a required deceleration ramp or parameter LIM_I_maxQSTP to set a required maximum current.
- Maximum current* The drive absorbs excess braking energy during. If the DC bus voltage exceeds the permissible limit the power stage is disabled and the device signals "DC bus overvoltage". The motor coasts down without any braking force.
- The current for the moment ramp should be set in such a way that the drive comes to a standstill with the required deceleration.
- "Quick Stop" ramp* The "Quick Stop" ramp must be set in such a way that the drive comes to a standstill with the desired deceleration when the function is triggered.
- The drive absorbs excess braking energy during deceleration. If the DC bus voltage exceeds the permissible limit the power stage is disabled and the device signals "DC bus overvoltage". The motor coasts down without any braking force.
- "Quick Stop reset"* A "Quick Stop" must be reset by a "Fault Reset".
- If a "Quick Stop" has been triggered by the positive or negative limit switch the drive can be moved back into the movement range via the jog operating mode.

Parameter Name	Description	Unit Minimum value Default value Maximum value	Data type R/W persistent Expert	Parameter address via fieldbus
LIM_QStopReact	Type of deceleration for Quick Stop 6 / Deceleration ramp: Deceleration ramp 7 / Torque ramp: Torque ramp Setting of deceleration ramp with parameter RAMPquickstop. Setting of torque ramp with parameter LIM_I_maxQSTP. The deceleration ramp is only available for operating modes with profile generator. The torque ramp is used in the operating modes without profile generator.	- 6 7 7	INT16 R/W per. -	Modbus 1584

Parameter Name	Description	Unit Minimum value Default value Maximum value	Data type R/W persistent Expert	Parameter address via fieldbus
RAMPquickstop	Deceleration ramp for Quick Stop Deceleration of the drive when a software stop is triggered or if an error of error class 1 has occurred.	min ⁻¹ /s 200 6000 3000000	UINT32 R/W per. -	Modbus 1572
LIM_I_maxQSTP	Current limitation for Quick Stop Max. current during braking via torque ramp due to an error of error classes 1 or 2 and when a software stop is triggered. Maximum and default settings depend on the motor and the power stage (settings M_I_max and PA_I_max) In increments of 0.01A _{pk}	A _{pk} - - -	UINT16 R/W per. -	Modbus 4362

8.6.5 Halt

Function principle The "Halt" function is an interruption function used to stop the motor and temporarily interrupt operation.

Internal position adjustment is performed once the drive comes to a standstill. Position control is activated and the motor is stopped with the power stage remaining enabled.

When all "Halt" requests are cleared, the interrupted movement is resumed. If the "Halt" request is already cleared during deceleration, the drive continues to decelerate until it comes to a standstill and then accelerates again.

The "Halt" function can be activated by any source (such as commissioning software or signal input).

The motor can be decelerated via a deceleration ramp or a maximum current. Use the parameter `LIM_HaltReaction` to set the type of deceleration.

- ▶ Set the type of deceleration with the `LIM_HaltReaction` parameter.
- ▶ Use parameter `RAMPdecel` to define a required deceleration ramp or parameter `LIM_I_maxHalt` to set a required maximum current.

Maximum current The drive absorbs excess braking energy during. If the DC bus voltage exceeds the permissible limit the power stage is disabled and the device signals "DC bus overvoltage". The motor coasts down without any braking force.

The current for the moment ramp should be set in such a way that the drive comes to a standstill with the required deceleration.

"Halt" ramp The "Halt" ramp must be set in such a way that the drive comes to a standstill with the desired deceleration after a "Halt" request.

The drive absorbs excess braking energy during deceleration. If the DC bus voltage exceeds the permissible limit the power stage is disabled and the device signals "DC bus overvoltage". The motor coasts down without any braking force.

Parameter Name	Description	Unit Minimum value Default value Maximum value	Data type R/W persistent Expert	Parameter address via fieldbus
LIM_HaltReaction	Type of deceleration for halt 1 / Deceleration ramp: Deceleration ramp 3 / Torque ramp: Torque ramp Setting of deceleration ramp with parameter <code>RAMPdecel</code> . Setting of torque ramp with parameter <code>LIM_I_maxHalt</code> . The deceleration ramp is only available for operating modes with profile generator. The torque ramp is used in the operating modes without profile generator.	- 1 3 3	INT16 R/W per. -	Modbus 1582

Parameter Name	Description	Unit Minimum value Default value Maximum value	Data type R/W persistent Expert	Parameter address via fieldbus
RAMPdecel	Deceleration of profile generator	min ⁻¹ /s 750 750 3000000	UINT32 R/W per. -	Modbus 1558
LIM_I_maxHalt	Current limitation for Halt Max. current during braking after Halt or when an operating mode is terminated. Maximum and default settings depend on the motor and the power stage (settings M_I_max and PA_I_max) In increments of 0.01A _{pk}	A _{pk} - - -	UINT16 R/W per. -	Modbus 4364

8.6.6 Fast position capture

The "Fast position capture" function captures the current motor position at the point in time a digital 24V signal is available at one of the two capture inputs. For example, this function can be used for detection of registration marks.

Settings 2 independent capture inputs are available for the "Fast Position Capture" function.

- LIO1 (CAP1)
- LIO2 (CAP2)

One of 2 possible functions for capture can be selected for each capture input:

- Position capture with rising or falling edge at the capture input, adjustable with parameters CAP1CONFIG and CAP2CONFIG.
- One-time or continuous capture with multiple change of edge at the capture input with parameters CAP1ACTIVATE and CAP2ACTIVATE.

Continuous capture means that the motor position is captured anew at every defined edge; the previous captured value is lost.

The CAP1 and CAP2 capture inputs have a time constant of $t = 10 \mu\text{s}$.

The captured motor position is less accurate during the acceleration phase and the deceleration phase.

Activating fast position capture Activating one-time position capture

- For CAP1: Write value 1 to parameter Cap1Activate
- For CAP2: Write value 1 to parameter Cap2Activate

Activating continuous position capture

- For CAP1: Write value 1 to parameter Cap1Activate
- For CAP2: Write value 2 to parameter Cap2Activate

Terminating position capture In the case of one-time single position capture, the "fast position capture" function is terminated when the first signal edge is detected.

In the case continuous position capture or if no signal edge is detected, the capture can be stopped by writing the parameter Cap1Activate, value 0 or Cap2Activate, value 0.

Parameter Name HMI menu	Description	Unit Minimum value Default value Maximum value	Data type R/W persistent Expert	Parameter address via fieldbus
Cap1Activate	Capture unit 1 start/stop 0 / Capture stop: Cancel capture function 1 / Capture once: Start one-time capture 2 / Capture continuous: Start continuous capture In the case of one-time capture, the function is terminated when the first value is captured. In the case of continuous capture, the function continues to run.	- 0 - 2	UINT16 R/W - -	Modbus 2568

Parameter Name HMI menu	Description	Unit Minimum value Default value Maximum value	Data type R/W persistent Expert	Parameter address via fieldbus
Cap1Config	Capture unit 1 configuration 0 / 1->0 : Position capture at 1->0 change 1 / 0->1 : Position capture at 0->1 change	- 0 0 1	UINT16 R/W - -	Modbus 2564
Cap1Count	Capture unit 1 event counter Counts the capture events. The counter is reset when capture unit 1 is activated.	- - 0 -	UINT16 R/- - -	Modbus 2576
Cap1Pos	Capture unit 1 captured position Captured position at the time of the "capture signal". The captured position is calculated again after "Position Setting" or "Homing".	usr - 0 -	INT32 R/- - -	Modbus 2572
Cap2Activate	Capture unit 2 start/stop 0 / Capture stop : Cancel capture function 1 / Capture once : Start one-time capture 2 / Capture continuous : Start continuous capture In the case of one-time capture, the function is terminated when the first value is captured. In the case of continuous capture, the function continues to run.	- 0 - 2	UINT16 R/W - -	Modbus 2570
Cap2Config	Capture unit 2 configuration 0 / 1->0 : Position capture at 1->0 change 1 / 0->1 : Position capture at 0->1 change	- 0 0 1	UINT16 R/W - -	Modbus 2566
Cap2Count	Capture unit 2 event counter Counts the capture events. The counter is reset when capture unit 2 is activated.	- - 0 -	UINT16 R/- - -	Modbus 2578
Cap2Pos	Capture unit 2 captured position Captured position at the time of the "capture signal". The captured position is calculated again after "Position Setting" or "Homing".	usr - 0 -	INT32 R/- - -	Modbus 2574
CapStatus	Status of the capture units Read access: Bit 0: position capture via input CAP1 carried out Bit 1: position capture via input CAP2 carried out	- - 0 -	UINT16 R/- - -	Modbus 2562

8.6.7 Standstill window

The standstill window can be used to check whether the drive has reached the reference position.

If the control deviation $_p_dif$ of the position controller remains in the standstill window after the end of the positioning for the period $STANDpwinTime$, the device signals the end of processing ($x_end = 0 > 1$).

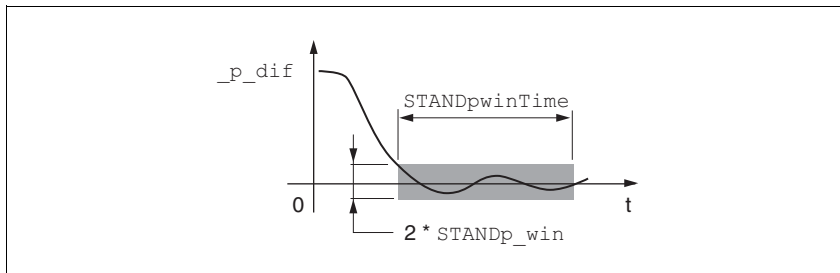

Figure 8.33 Standstill window

The parameters $STANDp_win$ and $STANDpwinTime$ define the size of the window.

The parameter $STANDpwinTout$ can be used to set the period of time after which an error is signaled if the standstill window was not reached.

Parameter Name	Description	Unit Minimum value Default value Maximum value	Data type R/W persistent Expert	Parameter address via fieldbus
STANDp_win	Standstill window, permissible control deviation The control deviation for the standstill window time must be within this range for a standstill of the drive to be detected. Processing of the standstill window must be activated via the parameter 'STANDpwinTime.	revolution 0.0000 0.0010 3.2767	UINT16 R/W per. -	Modbus 4370
STANDpwinTime	Standstill window, time 0: Monitoring of standstill window deactivated >0: Time in ms during which the control deviation must be in the standstill window	ms 0 0 32767	UINT16 R/W per. -	Modbus 4372
STANDpwinTout	Timeout time for standstill window monitoring 0 : Timeout monitoring deactivated >0 : Timeout time in ms Standstill window processing values are set via $STANDp_win$ und $STANDpwinTime$. Time monitoring starts when the target position (reference position of position controller) is reached or when the profile generator has finished processing.	ms 0 0 16000	UINT16 R/W per. -	Modbus 4374

0198441113652, V2.00, 11.2008

8.6.8 Brake function

Use motors with a holding brake to avoid unintended movement of the motor when no current is applied.

The holding brake is not available with all product versions.

⚠ WARNING
<p>LOSS OF BRAKING FORCE DUE TO WEAR OR HIGH TEMPERATURE</p> <p>Applying the holding brake while the motor is running will cause excessive wear and loss of the braking force. Heat decreases the braking force.</p> <ul style="list-style-type: none"> • Do not use the brake as a service brake. • Note that "EMERGENCY STOPS" may also cause wear • At operating temperatures of more than 80°C (176°F), do not exceed a maximum of 50% of the specified holding torque when using the brake. <p>Failure to follow these instructions can result in death, serious injury or equipment damage.</p>

Control The integrated holding brake is controlled automatically.

Releasing the holding brake The holding brake is automatically released when the power stage is enabled. After a delay time the drive switches to operating state "Operation Enable".

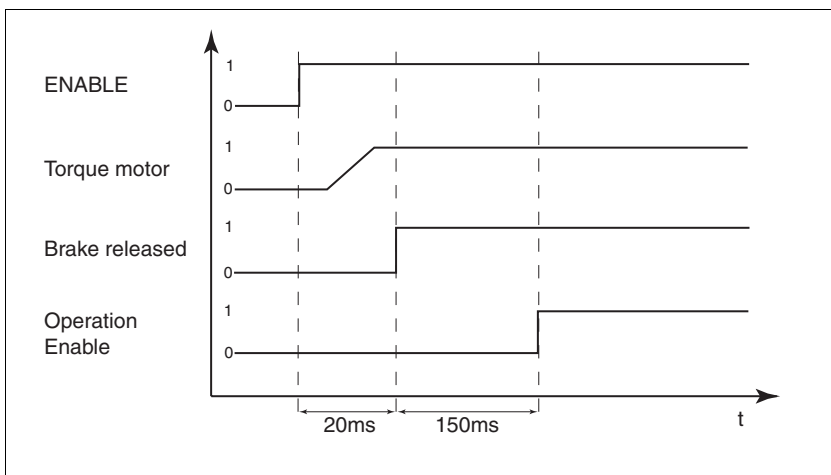

Figure 8.34 Releasing the holding brake

019844113652, V2.00, 11.2008

Applying the holding brake

When the power stage is disabled and in the event of an error of error class 2, the holding brake is automatically applied. However, the motor current is not disconnected until after a delay time. This allows the holding brake to be applied before the motor loses its torque.

In the event of an error of error classes 3 or 4, the holding brake is automatically applied and the motor current is immediately disconnected.

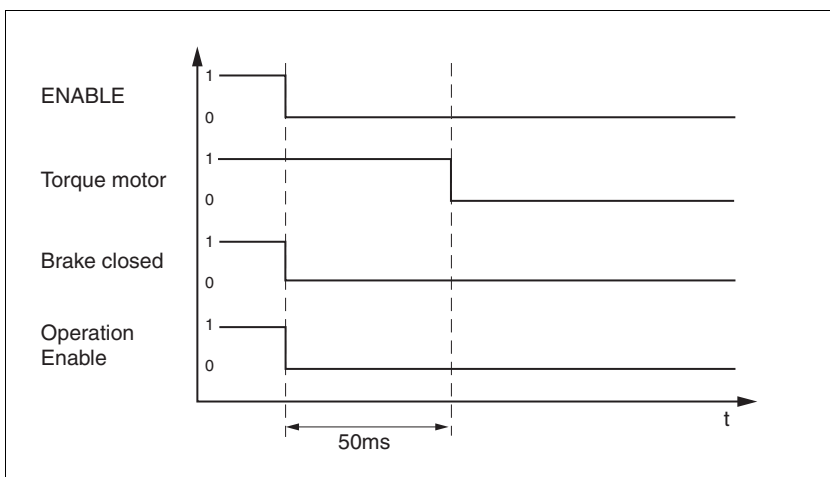

Figure 8.35 Applying the holding brake

The delay time is not effective if the power stage is disabled via the STO safety function. Especially in the case of vertical axes it is important to verify whether additional measures are required to avoid lowering of the load.

8.6.9 Configurable inputs and outputs

⚠ WARNING
UNINTENDED BEHAVIOR OF INPUTS AND OUTPUTS
The functions of the inputs and outputs depend on the selected start-up operating mode and the settings of the corresponding parameters.
<ul style="list-style-type: none"> • Verify that the wiring is appropriate for the settings. • Only start the system if there are no persons or obstructions in the hazardous area. • When commissioning, carefully run tests for all operating states and potential fault situations.
Failure to follow these instructions can result in death, serious injury or equipment damage.

Description Different functions can be assigned to the digital signal inputs and outputs.

The parameters IOfuncnt_LIO1 ... IOfuncnt_LIO4 are available to configure the function

Factory settings The following table provides an overview of the factory settings.

Pin	Signal	Factory setting	I/O
CN4.3	LIO1	Input Positive limit switch (LIMP)	I
CN4.6	LIO2	Input Negative limit switch (LIMN)	I
CN4.2	LIO3	Input Free available	I
CN4.5	LIO4	Input Reference switch (REF)	I

Current status The _IO_LIO_act parameter indicates the current status of the digital signal inputs or outputs.

Parameter Name	Description	Unit Minimum value Default value Maximum value	Data type R/W persistent Expert	Parameter address via fieldbus
_IO_LIO_act	Status of digital inputs/outputs Coding of the individual signals: Bit 0: LIO1 Bit 1: LIO2 ...	- - 0 -	UINT16 R/- - -	Modbus 2090

019844113652, V2.00, 11.2008

8.6.9.1 Description of functions for signal inputs

<i>No function / free available</i>	The function "No function / free available" has no device-internal functionality. The signal input can be read as required via the parameter <code>_IO_LIO_act</code> .
<i>Fault reset</i>	An error message is reset with the function, see chapter 8.3 "Operating states".
<i>Enable</i>	The power stage is enabled with the function, see chapter 8.3 "Operating states".
<i>Halt</i>	The function triggers a "Halt", see chapter 8.6.5 "Halt".
<i>Jog positive</i>	The function performs a jog movement with clockwise direction of rotation, see chapter 8.5.1 "Operating mode Jog".
<i>Jog negative</i>	The function performs a jog movement with counterclockwise direction of rotation, see chapter 8.5.1 "Operating mode Jog".
<i>Jog fast/slow</i>	The function switches between slow and fast jog, see chapter 8.5.1 "Operating mode Jog".
<i>Reference switch (REF)</i>	The function defines the way the reference switch operates. See chapter 8.5.5 "Operating mode Homing".
<i>Positiv limit switch (LIMP)</i>	The function defines the way the positive limit switch operates. See chapter 8.5.5 "Operating mode Homing" and chapter 8.6.1.2 "Positioning range".
<i>Negative limit switch (LIMN)</i>	The function defines the way the negative limit switch operates. See chapter 8.5.5 "Operating mode Homing" and chapter 8.6.1.2 "Positioning range".

8.6.9.2 Description of functions for signal outputs

<i>No function / free available</i>	The function "No function / free available" lets you directly set an output via parameter <code>IO_LO_set</code> .
<i>No fault</i>	The function provides information on the error state, see chapter 8.3.2 "Indicating the operating states".
<i>Active</i>	The function provides the "Operation enable" operating state signal, see chapter 8.3.2 "Indicating the operating states".

Parameter Name	Description	Unit Minimum value Default value Maximum value	Data type R/W persistent Expert	Parameter address via fieldbus
IO_LO_set	Setting the digital outputs directly Write access to output bits is only active if the signal pin is available as an output and if the function of the output was set to 'Available as required'. Coding of the individual signals: Bit 0: LO1_OUT Bit 1: LO2_OUT ...	- - 0 -	UINT16 R/W - -	Modbus 2082

8.6.9.3 Configuration of the signal inputs and outputs

The table below provides an overview of the signal inputs and outputs to which a function can be assigned.

Functions for signal inputs

Function	Signal
No function / free available	LIO1, LIO2, LIO3, LIO4
Fault reset	LIO1, LIO2, LIO3, LIO4
Enable	LIO1, LIO2, LIO3, LIO4
Halt	LIO1, LIO2, LIO3, LIO4
Jog positive	LIO1, LIO2, LIO3, LIO4
Jog negative	LIO1, LIO2, LIO3, LIO4
Jog fast/slow	LIO1, LIO2, LIO3, LIO4
Reference switch (REF)	LIO1, LIO2, LIO3, LIO4
Positiv limit switch (LIMP)	LIO1
Negative limit switch (LIMN)	LIO2

Functions for signal outputs

Function	Jog
No function / free available	LIO1, LIO2, LIO3, LIO4
No fault	LIO1, LIO2, LIO3, LIO4
Active	LIO1, LIO2, LIO3, LIO4

Parameter Name	Description	Unit Minimum value Default value Maximum value	Data type R/W persistent Expert	Parameter address via fieldbus
IOfunct_LIO1	Function Input/Output LIO1 1 / Input Free available: Available as required 2 / Input Fault reset: Reset fault (local control mode only) 3 / Input Enable: Enable (local control mode only) 4 / Input Halt: Halt 9 / Input Jog positive: Jog positive 10 / Input Jog negative: Jog negative 11 / Input Jog fast/slow: Jog fast/slow 20 / Input Reference switch (REF): Reference switch (REF) 21 / Input Positive limit switch (LIMP): Positive limit switch (LIMP) 101 / Output Free available: Available as required 102 / Output No fault: No fault 103 / Output Active: Ready	- - 0 -	UINT16 R/W per. -	Modbus 1826

019844113652, V2.00, 11.2008

Parameter Name	Description	Unit Minimum value Default value Maximum value	Data type R/W persistent Expert	Parameter address via fieldbus
IOfunct_LIO2	Function Input/Output LIO2	-	UINT16 R/W per. -	Modbus 1828
	1 / Input Free available: Available as required	0		
	2 / Input Fault reset: Reset fault (local control mode only)	-		
	3 / Input Enable: Enable (local control mode only)	-		
	4 / Input Halt: Halt	-		
	9 / Input Jog positive: Jog positive	-		
	10 / Input Jog negative: Jog negative	-		
	11 / Input Jog fast/slow: Jog fast/slow	-		
	20 / Input Reference switch (REF): Reference switch (REF)	-		
	22 / Input Negative limit switch (LIMN): Negative limit switch (LIMN)	-		
	101 / Output Free available: Available as required	-		
	102 / Output No fault: No fault	-		
	103 / Output Active: Ready	-		
IOfunct_LIO3	Function Input/Output LIO3	-	UINT16 R/W per. -	Modbus 1830
	1 / Input Free available: Available as required	0		
	2 / Input Fault reset: Reset fault (local control mode only)	-		
	3 / Input Enable: Enable (local control mode only)	-		
	4 / Input Halt: Halt	-		
	9 / Input Jog positive: Jog positive	-		
	10 / Input Jog negative: Jog negative	-		
	11 / Input Jog fast/slow: Jog fast/slow	-		
	20 / Input Reference switch (REF): Reference switch (REF)	-		
	101 / Output Free available: Available as required	-		
	102 / Output No fault: No fault	-		
	103 / Output Active: Ready	-		
	IOfunct_LIO4	Function Input/Output LIO4		
1 / Input Free available: Available as required		0		
2 / Input Fault reset: Reset fault (local control mode only)		-		
3 / Input Enable: Enable (local control mode only)		-		
4 / Input Halt: Halt		-		
9 / Input Jog positive: Jog positive		-		
10 / Input Jog negative: Jog negative		-		
11 / Input Jog fast/slow: Jog fast/slow		-		
20 / Input Reference switch (REF): Reference switch (REF)		-		
101 / Output Free available: Available as required		-		
102 / Output No fault: No fault		-		
103 / Output Active: Ready		-		

8.6.10 Reversal of direction of rotation

The parameter `POSdirOfRotat` can be used to reverse the direction of rotation of the motor. Note that changed settings do not become active until after the device is switched off and on again.

Connect the limit switch that limits the working range for clockwise rotation to `LIMP`. Connect the limit switch that limits the working range for counterclockwise rotation to `LIMN`.

Parameter Name	Description	Unit Minimum value Default value Maximum value	Data type R/W persistent Expert	Parameter address via fieldbus
POSdirOfRotat	Definition of direction of rotation 0 / clockwise: Clockwise 1 / counter clockwise: Counter-clockwise Meaning: At positive speeds, the drive rotates clockwise (looking at the motor shaft at the flange). NOTE: If you use limit switches, you must interchange the limit switch connections after changing the settings. The limit switch which is reached with a jog movement in positive direction must be connected to the LIMP input and vice versa. NOTE: Changed settings do not become active until the unit is switched on the next time.	- 0 0 1	UINT16 R/W per. -	Modbus 1560

If the direction of rotation of the motor must be reversed, all parameter values can be imported unchanged.

Reversal of the direction of rotation changes the absolute position of the motor `_p_absworkusr` (read from the encoder) as well as the actual position `_p_actusr` determined by the device.

Therefore, the direction of rotation must be set during commissioning as it will be used during later operation of this motor.

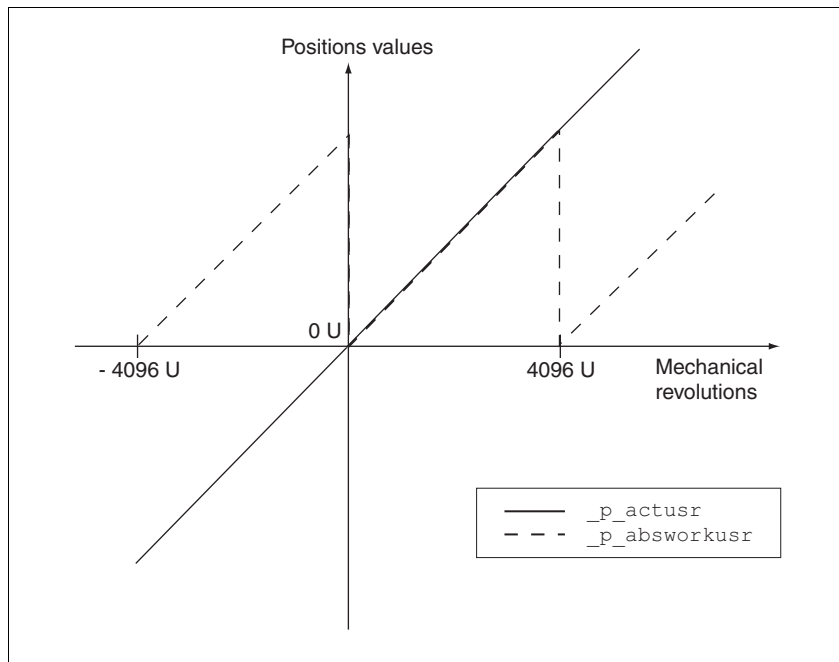

Figure 8.36 Position values without reversal of direction of rotation

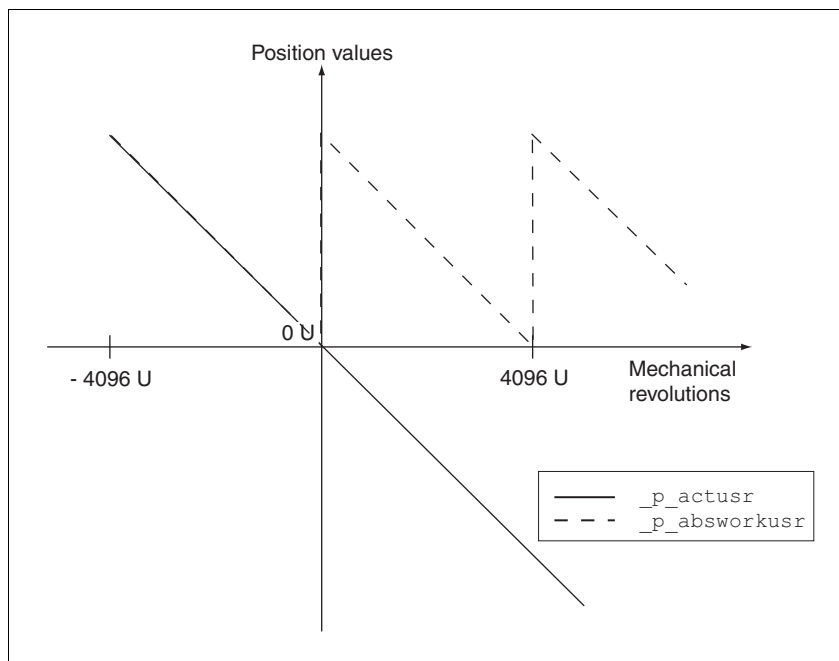

Figure 8.37 Position values with reversal of direction of rotation

8.6.11 Restoring default values



All parameter values set by the user are lost in this process. It is possible at any time to save all parameter values set for a device as a configuration using the commissioning software.

8.6.11.1 Resetting user parameters

Parameter `PARuserReset` is used to reset all parameter values to the default values, except for the communication parameters.

Parameter Name	Description	Unit Minimum value Default value Maximum value	Data type R/W persistent Expert	Parameter address via fieldbus
PARuserReset	Reset user parameters Bit 0 = 1: Set persistent parameters to default values. All parameters are reset with the exception of: - Communication parameters - Definition of the direction of rotation - Signal selection position interface - I/O functions NOTE: The new settings are not saved to the EEPROM!	- 0 - 7	UINT16 R/W - -	Modbus 1040

8.6.11.2 Restoring the factory settings

Factory settings via commissioning software

The factory settings are loaded via the menu items Configuration => Factory Settings. All parameter values are reset to the default values. The new settings only become active until after the device is switched off and on again.

- ▶ Disconnect the product from the the fieldbus in order to avoid conflicts by simultaneous access.

8.6.12 I/O Scanning

8.6.12.1 General

In order to control the drive by means of I/O Scanning as simply as possible, all required information is contained in adjacent registers. This way, all information can be exchanged between controller and drive with a single read and write access. This facilitates configuration of I/O Scanning in the controller.

This is implemented by access to the registers described below. For each direction, there are 2 registers with 32 bits each. Modbus only allows for access to 32 bit registers. A 16 bit access results in an error.

A write access requires the access channel to be available for Modbus and not be blocked. Chapter 8.2 "Access control" describes the way the access channel can be blocked for other users so that exclusive access is possible.

8.6.12.2 Controlling the drive

To control the drive via I/O scanning, registers 6922 and 6924 are available to the controller. The drive can be controlled by writing to these registers. Structure of the registers:

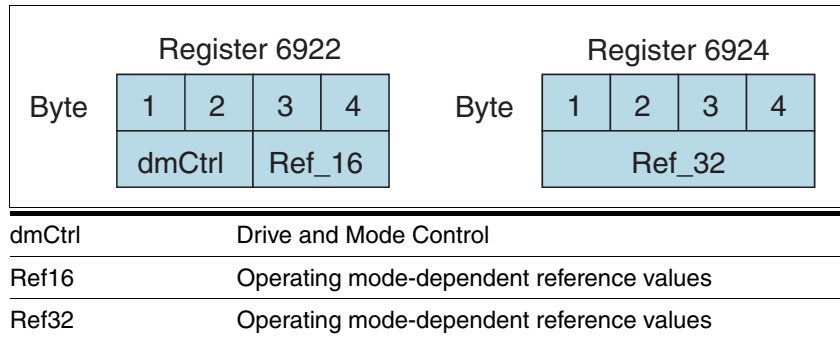

Structure of dmCtrl

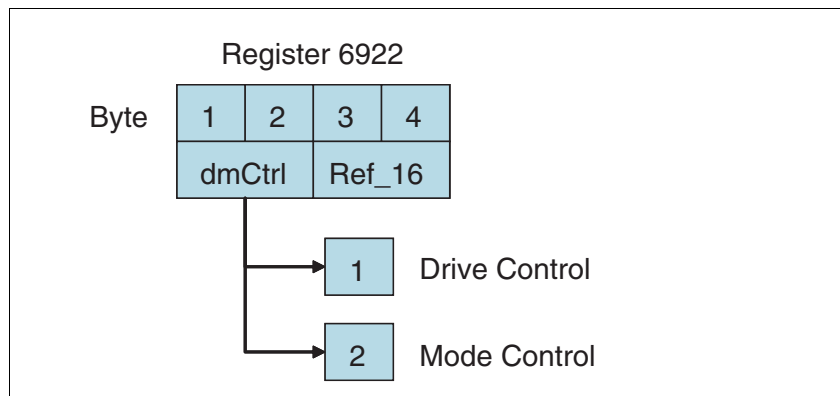

019844113652, V2.00, 11.2008

Drive Control

Drive Control control the operating states of the drive. A rising edge triggers a function. Changes are processed immediately.

	CU	CH	SH	0	FR	QS	EN	DI
Bit	15	14	13	12	11	10	9	8

Bit	Name	Meaning
8	DI	Disable power stage
9	EN	Enable power stage
10	QS	Execute "Quick Stop" function
11	FR	Execute "Fault Reset" function
12	-	Reserved
13	SH	Execute "Halt" function
14	CH	Clear "Halt" function
15	CU	Resume operating mode interrupted by "Halt"

The value 0 is a special case: If during transmission all bits have the value 0, this corresponds to a Disable command and the power stage is disabled.

Handling of errors

If requests for controlling the state machine cannot be executed by the drive, there is no response. This means that the drive ignores such requests.

Example: Transmission of a Quick Stop request in state 4 "Ready-ToSwitchOn".

Treatment of ambivalent bit combinations:

Bit 8 has precedence over bit 9.

Bit 13 has precedence over bit 14 and bit 15.

Bit 10 has precedence over bit 11.

Mode Control

The operating modes are controlled by means of the Mode Control entry.

Bit	7	6	5	4	3	2	1	0
	MT	action			mode			
Bit	Name	Description						
0 ... 3	MODE	Indicates the currently selected operating mode	1: Jog 2: Homing 3: Profile Position 4: Profile Velocity 7: Speed Control					
4 ... 6	ACTION	Operating mode-dependent action						
7	MT	Handshake via "Mode Toggle"						

The following table shows the possible operating modes and the associated reference values:

Mode	Action	modeCtrl* Bit 0..6	Description	Reference value Ref_16	Reference value Ref_32
1	0	01h	Jog	Corresponds to parameter JOGactivate	-
2	0	02h	Homing: Position setting	-	Position for position setting Corresponds to parameter HMP_homeusr
	1	12h	Homing: Reference movement	Homing method Corresponds to parameter HMmethod	-
3	0	03h	Profile Position: Absolute positioning	Target speed of rotation Corresponds to parameter PPn_target	Target position Corresponds to parameter Pp_absusr
	1	13h	Profile Position: Relative positioning with reference to the currently set target position	Target speed of rotation Corresponds to parameter PPn_target	Target position Corresponds to parameter Pp_relprefusr
	2	23h	Profile Position: Relative positioning with reference to the current motor position	Target speed of rotation Corresponds to parameter PPn_target	Target position Corresponds to parameter Pp_relpactusr
4	0	04h	Profile Velocity	Target speed of rotation Corresponds to parameter PPn_target	-
7	1	17h	Speed Control	Reference speed Corresponds to parameter SPEEDn_target	-

The value 0 in `modeCtrl` is a special case: If during transmission all bits 0..7 are zero, the following data is not processed; no error message is generated.

If operating mode, reference position and reference speed are transmitted simultaneously with one access, data consistency is required. For this reason, the drive evaluates the operating mode data only if `ModeToggle` (bit 7) was toggled.

Toggling means that a 0>1 or a 1>0 change of edge has been detected since the last transmission.

The controller must enter the following values to activate an operating mode or to change reference values:

1. Enter the reference values in the fields `ref_16` and `ref_32` (0 must be entered in unused fields)
2. Select the operating mode with `modeCtrl` bits 0..3 (mode)
3. Select the action for this operating mode with `modeCtrl` bits 4..6 (action)
4. Toggle `modeCtrl` bit 7 (MT)

8.6.12.3 Response from the drive

Registers 6926 and 6928 are available to the controller for response from the drive. The status of the drive can be determined by reading these registers.

Structure of the registers:

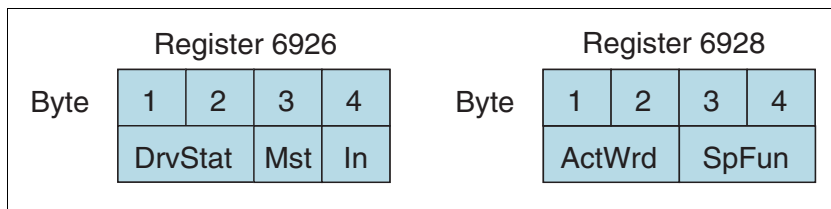

DrvStat	Drive status
Mst	Mode status
In	Drive input
ActWrd	Action word
SpFun	Special function

Drive Status

The status of the drive is returned by means of Drive Status:

Structure Drive Status, byte 1

	x_Error	x_End	x_Info	0	0	0	0	Halt
Bit	15	14	13	12	11	10	9	8

Structure Drive Status, byte 2

	Warn	Fault	0	State				
Bit	7	6	5	4	3	2	1	0

Bit	Name	Meaning
0 ... 3	STATE	Current operating state
6	FAULT	An error has occurred
7	WARN	A warning was generated
8	HALT	"Halt" function is active
9 ... 12	-	Reserved
13	x_info	Additional information on operating mode
14	x_end	Termination identifier operating mode
15	x_err	Error identifier operating mode

Mode Status

modeStat indicates the current processing state of the operating modes.

Structure Mode Status

	MT	ME	RF	0	mode			
Bit	7	6	5	4	3	2	1	0

Bit	Name	Description
0 ... 3	MODE	Indicates the currently selected operating mode 1: Jog 2: Homing 3: Profile Position 4: Profile Velocity 7: Speed Control
4	-	Reserved
5	RF	Is set if operating mode Homing was successfully completed
6	ME	Is set if a request from a master was rejected
7	MT	Handshake via "Mode Toggle"

Synchronized processing is possible with the request bit ModeToggle (MT) from register 6922 that is written to the drive and the status bits ModeToggle (MT) along with ModeError (ME) from register 6926. Synchronized means that the controller waits for response from the drive and acts appropriately.

If a request for an operating mode sent via the transmit data telegram cannot be processed, the drive rejects processing and sets `modeStat`, bit 6 (`ModeError`) in the receive data telegram. This does not interrupt the current process. To determine the cause of the error, the controller can read the error number from the `ModeError` parameter, register 6962 by means of an access via the parameter channel.

Drive Input

Drive Input indicates the current levels of the inputs at the drive.

Structure Drive Input

	0	0	I_5	I_4	I_3	I_2	I_1	I_0
Bit	7	6	5	4	3	2	1	0

Meaning of the bits

I_0	LIO1, input positive limit switch
I_1	LIO2, input negative limit switch
I_2	LIO3, available as required
I_3	LIO4, input reference switch
I_4	STO_A
I_5	STO_B

If the signals are forced to specific levels, these forced levels are output here. Forcing is only possible with the commissioning software.

Action Word

The relevant bits of Action Word are explained below.

Structure Action Word, byte 5

	0	CNST	ACC	DEC	TAR0	0	PWIN	MOTN
Bit	15	14	13	12	11	10	9	8

Structure Action Word, byte 6

	MOTP	MOTZ	0	0	0	0	0	0
Bit	7	6	5	4	3	2	1	0

Meaning of the bits

MOTZ	Motion Zero: Current speed is 0
MOTP	Motion Positive: Motor moves in positive direction (clockwise)
MOTN	Motion Negative : Motor moves in negative direction (counter-clockwise)
PWIN	Inside position window
TAR0	Profile generator: Target speed is 0
DEC	Profile generator: Deceleration
ACC	Profile generator: Acceleration
CNST	Profile generator: Constant movement

019844113652, V2.00, 11.2008

Special Function

For certain processing functions, the relevant status bits are output in this data word. Currently, the processing status of the Capture function is signaled.

Structure Special Function, byte 7

	0	0	0	0	0	0	0	0
Bit	15	14	13	12	11	10	9	8

Structure Special Function, byte 8

	0	0	0	0	CAP2 1	CAP2 0	CAP1 1	CAP1 0
Bit	7	6	5	4	3	2	1	0

Meaning of the bits

CAP1_1/ Bits 0 and 1 of the CAP1 position capture counter
CAP1_0

CAP2_1/ Bit 0 and 1 of the counter of the position capture by CAP2
CAP2_0

9 Examples

9.1 Wiring examples

The following figure shows a typical wiring example. The limit switches and the reference switch are supplied via the internal 24V signal power supply.

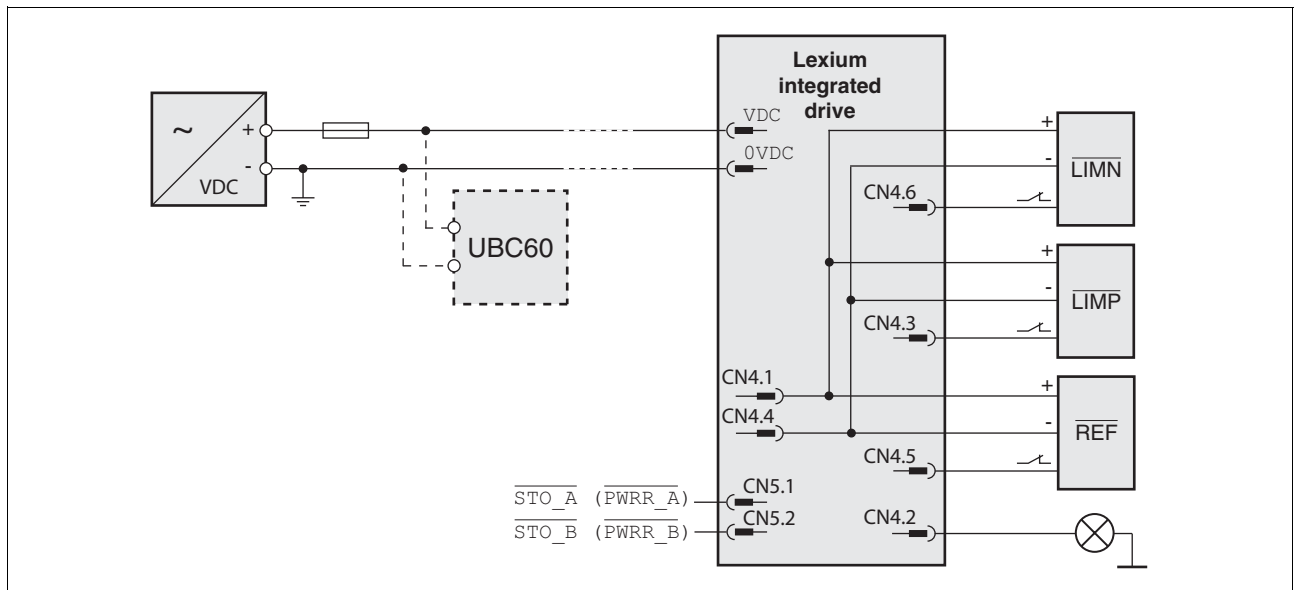

Figure 9.1 Wiring example

The UBC60 braking resistor controller is available as an accessory, see chapter 12 "Accessories and spare parts".

9.2 Wiring of the "STO safety function"

Using the safety functions integrated in this product requires careful planning. For more information see chapter 5.4 "Safety function STO ("Safe Torque Off")" on page 48.

9.3 Sample settings

Please contact your local sales office for examples of device settings.

10 Diagnostics and troubleshooting

10.1 Service

If you cannot resolve an error yourself please contact your sales office. Have the following details available:

- Nameplate (type, identification number, serial number, DOM, ...)
- Type of error (such as LED flash code or error number)
- Previous and concomitant circumstances
- Your own assumptions concerning the cause of the error

Also include this information if you return the product for inspection or repair.

10.2 Error indication

The last cause of stop and the last 10 error messages are stored. You can display the last 10 error messages using the commissioning software and the fieldbus.

For a description of all error numbers, see chapter 10.4 "Table of error numbers".

Asynchronous errors Asynchronous errors are triggered by internal monitoring (for example, temperature) or by external monitoring (for example, limit switch). An error response is initiated if an asynchronous error occurs.

Asynchronous errors are indicated in the following way:

- Transition to operating state "Quick Stop" or to operating state "Fault".
- Information in parameter `DCOMstatus`
- Error number is written to parameter `StopFault`

Synchronous errors Synchronous errors occur as direct errors in response to a fieldbus command. They comprise, for instance:

- Error during execution of an action command or control command
- Parameter value outside the permissible value range
- Invalid action command or control command during processing
- Access to unknown parameter

10.2.1 State diagram

For a detailed description of the state diagram, see chapter 8.3.1 "State diagram".

10.2.2 LED signal codes

The following illustration shows a selection of the possible LED states and signals. The times may differ up to 20% from the values indicated.

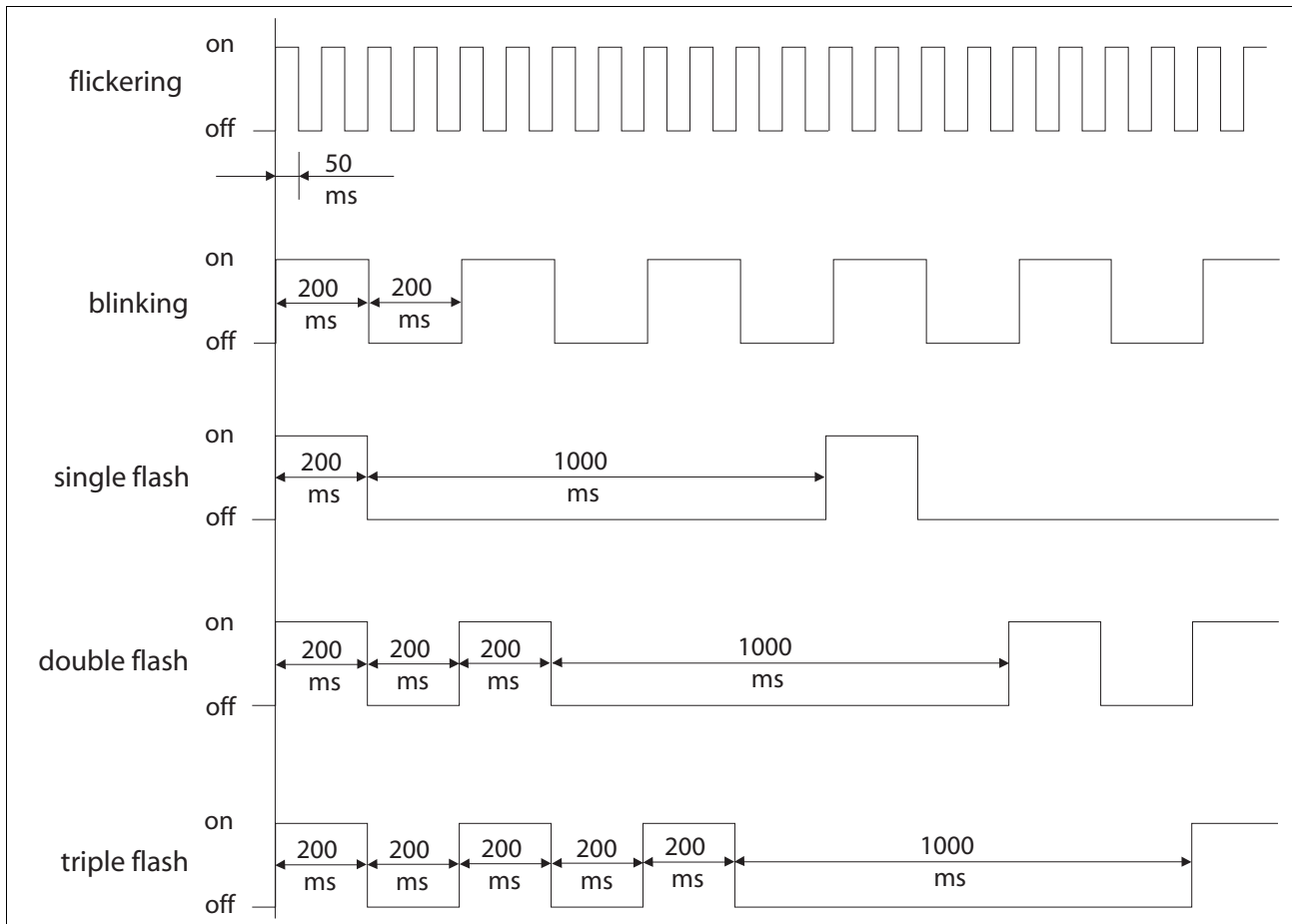

Figure 10.1 LED signals (selection)

10.2.3 Error and status indication via LEDs

Modbus TCP LED The product features a green RUN LED to indicate the Ethernet fieldbus states.

LED state	Meaning RUN LED
Flashes	System booting
On	Ready, no error
Flashes twice per cycle	No connection
Flashes 3 times per cycle	No valid IP parameters after Clear IP
Flashes 4 times per cycle	Double IP address detected
Flashes 5 times per cycle	Waiting for Bootsstrap Protocol/address from DHCP server
Flashes 6 times per cycle	Default IP address mode for various reasons

10.2.4 Diagnostics via Web server

See chapter 7.2.5 "Web server" for information on the Web server.

10.2.5 Error indication using the commissioning software

- You need a PC with the commissioning software and a working connection to the product, see chapter 6.3.7 "RS485 interface connection", page 70.
- ▶ Select "Diagnostics - Error memory". A dialog box which shows the error messages is displayed.

The commissioning software shows a 4 digit error number in the list of the error memory with a prefixed "E".

The error messages are displayed along with the status, error class, time when the error occurred and a short description. The "Additional information" lets you verify the exact conditions when the error occurred.

- ▶ Correct the error and reset the error message.
In the case of class 4 errors, you must switch off the controller supply voltage and switch it on again.

019844113652, V2.00, 11.2008

10.2.6 Error indication via the fieldbus

Cause of last stop The parameter `_StopFault` allows you to read out of the error number and the last cause of stop. If there is no error, the value of the parameter is 0. If an error occurs, the error is written to the error memory along with other status information. In the case of subsequent errors, only the triggering cause of error is stored.

Error memory The error memory is an error history of the last 10 errors; it is not cleared even if the device is switched off. The following parameters allow you to manage the error memory:

Parameter Name	Description	Unit Minimum value Default value Maximum value	Data type R/W persistent Expert	Parameter address via fieldbus
FLT_del_err	Clear error memory	-	UINT16	Modbus 15112
	1: Delete all entries in the error memory	0	R/W	
	The clearing process is completed if a 0 is returned after a read access.	- 1	-	
FLT_MemReset	Reset error memory read pointer	-	UINT16	Modbus 15114
	1: Set error memory read pointer to oldest error entry.	0	R/W	
		- 1	-	

The error memory can only be read sequentially. The parameter `FLT_MemReset` must be used to reset the read pointer. Then the first error entry can be read. The read pointer is automatically set to the next entry; a read access delivers the next error entry. If the error number 0 is returned there is no error entry.

Position of the entry	Meaning
1	1. Error entry, oldest message
2	2. Error entry, later message, if present
...	...
10	10. error entry. In the case of 10 error entries the most current error value is contained here

An individual error entry consists of several pieces of information which are read out using various parameters. When you read out an error entry, the error number must be read out first with the parameter `FLT_err_num`.

Parameter Name	Description	Unit Minimum value Default value Maximum value	Data type R/W persistent Expert	Parameter address via fieldbus
FLT_err_num	Error number Reading this parameter copies the entire error entry (error class, time of occurrence of error, ...) to an intermediate memory from which all elements of the error can then be read. In addition, the read pointer of the error memory is automatically set to the next error entry.	- 0 - 65535	UINT16 R/- - -	Modbus 15362
FLT_class	Error class 0: Warning (no response) 1: Error (Quick Stop -> state 7) 2: Error (Quick Stop -> state 8, 9) 3: Fatal error (state 9, can be acknowledged) 4: Fatal error (state 9, cannot be acknowledged)	- 0 - 4	UINT16 R/- - -	Modbus 15364
FLT_Time	Error time With reference to operating hours counter	s 0 - 536870911	UINT32 R/- - -	Modbus 15366
FLT_Qual	Error additional information This entry contains additional information on the error, depending on the error number. Example: a parameter address	- 0 - 65535	UINT16 R/- - -	Modbus 15368

10.3 Troubleshooting

10.3.1 Fieldbus communication

A properly operating fieldbus is essential for evaluating operating and error messages.

Checking connections

If the product cannot be addressed via the fieldbus, first check the connections.

Check the following connections:

- ▶ System power supply
- ▶ Supply connections
- ▶ Fieldbus cables and wiring
- ▶ Fieldbus connection

Also verify correct wiring of the limit switches (if installed) and the terminating resistors.

Fieldbus function test

If the connections are correct, check the settings for the fieldbus addresses. After correct configuration of the transmission data, test fieldbus mode.

- ▶ In addition to the master that knows the product via the EDS file and addressing, activate a bus monitor that, as a passive device, displays messages.
- ▶ Switch the supply voltage off and on.
- ▶ Observe the network messages that are generated briefly after the supply voltage is switched on. A bus monitor can be used to record the elapsed time between telegrams and the relevant information in the telegram.

Possible errors: Polling, parameter setting, configuration

If the connection to a device cannot be established, check the following:

- Address: Every network device must have a unique address.
- Parameterization: The vendor ID and the product code of the device must conform to the values stored in the EDS file.

10.3.2 Troubleshooting of errors sorted by error bit

To facilitate troubleshooting, all error numbers are categorized by so-called error bits. The error bits can be read using the parameter `_SigLatched`. Signal status "1" indicates an error or warning message.

Error bit	Meaning	Error class	Cause	Troubleshooting
0	General error	0		
1	Limit switch (LIMP/LIMN/REF)	1	Limit switch is or was activated, line interrupted	Move drive into movement range, match positioning data to axis range, special message in error memory
2	Range of travel exceeded (software limit switch, tuning range)	1	Motor not in area of travel	Check range of travel, home the drive again
3	"Quick Stop" via fieldbus	1	fieldbus command	
4	Inputs <code>STO_A</code> (<code>PWRR_A</code>) and <code>STO_B</code> (<code>PWRR_B</code>) are "0"	3	"STO" safety function was triggered	Check guard door, cabling
6	RS485 fieldbus error, Modbus		Interruption of the fieldbus communication, only with RS485, e.g. Modbus	Check the communication cables, check the fieldbus, check the communication parameters.
8	Ethernet fieldbus error		Communication interrupted or incorrect realtime data	Check the communication cables, check the fieldbus, check the communication parameters, check PLC application, if necessary.
10	Error in processing of the current operating mode	2	Processing error	For detailed information see additional information in the error memory
14	DC bus undervoltage	2	DC bus voltage below threshold value for "Quick Stop"	Check DC bus voltage
		3	DC bus voltage below threshold value for switch-off of the drive	
15	DC bus overvoltage	3	DC bus overvoltage, deceleration too fast	Extend braking process, use external braking resistor
18	Motor overload	3	Phase current too high	Reduce load
20	Undervoltage controller supply voltage		Controller supply voltage has fallen below the minimum value	Check controller supply voltage. Check for short-term voltage dips during load changes
21	Temperature of power stage too high	3	The power stage overheated	Reduce load
22	Tracking error	par. ¹⁾	Tracking error	Reduce external load or acceleration, error response is adjustable via "Fit_pDiff"
24	Inputs <code>STO_A</code> (<code>PWRR_A</code>) and <code>STO_B</code> (<code>PWRR_B</code>) are different	4	Interruption of the signal wires	Signal cable/connection to be checked, check signal encoder or change
29	EEPROM error	3-4	Checksum in EEPROM incorrect	Run a "First Setup", save the user-defined parameters to the EEPROM, contact your local sales office
30	System start-up error (hardware or parameter error)	3-4	Cause of error as indicated	Resolution depends on indicated cause of error

Error bit	Meaning	Error class	Cause	Troubleshooting
31	Internal system error (e. g. Watchdog)	4	Internal system error System error, e.g. division by 0 or timeout checks	Switch device off and on, replace device Comply with EMC measures, switch device off and on, contact your local sales office

1) par. = can be parameterized

10.4 Table of error numbers

The cause of error for each error message is coded as an error number and stored in the parameter `FLT_err_num`. The following table shows all the error numbers and their meaning. If "par." is shown with the error class, the error class is parameterizable.

Error number categories:

Error number	range
E 1xxx	General
E 2xxx	Overcurrent
E 3xxx	Voltage
E 4xxx	Temperature
E 5xxx	Hardware
E 6xxx	Software
E 7xxx	Interface, wiring
E Axxx	Motor movement
E Bxxx	Communication

Information on error bits and troubleshooting can be found on page 197.

Error class

The product triggers an error response in the event of a fault. Depending upon the severity of the fault, the device responds in accordance with one of the following error classes:

Error class	Reaction	Meaning
0	Warning	Message only, no interruption.
1	"Quick Stop"	Motor stops with "Quick Stop", power stage and controller remain switched on and enabled.
2	"Quick Stop" with switch-off	Motor stops with "Quick Stop", power stage and controller are disabled after standstill has been achieved.
3	Fatal error	Power stage and controller switch off immediately without stopping the motor first.
4	Uncontrolled operation	Power stage and controller switch off immediately without stopping the motor first. Error response can only be reset by switching off the device.

Error number	Class	Bit	Description, cause and correctives
E 1100	-	-	Parameter out of permissible range
E 1101	-	-	Parameter does not exist Fault signaled by parameter management: parameter (index) does not exist.
E 1102	-	-	Parameter does not exist Fault signaled by parameter management: parameter (subindex) does not exist.
E 1103	-	-	Parameter write not permissible (READ only) Write access to read only parameter.

019844113652, V2.00, 11.2008

Error number	Class	Bit	Description, cause and correctives
E 1104	-	-	Write access denied (no access authorization) Parameter only accessible at expert level. The write access level expert is required.
E 1106	-	-	Command not allowed while power stage is active Command not allowed while the power stage is enabled (state "OperationEnable" or "QuickStopActive"). Disable the power stage and repeat the command.
E 1107	-	-	Access via other interface blocked Access occupied by another channel (e.g.: commissioning software is active and fieldbus access was tried at the same time). Check the channel that blocks the access.
E 110B	3	30	Initialization error (additional info=Modbus register address) Error detected at power enable parameter check e.g. reference speed value for profile position is greater than max. allowed speed of drive. Value in additional error info shows the Modbus register address of the parameter where the initialization error was detected.
E 110E	-	-	Parameter changed that requires a restart of the drive Only displayed by the commissioning software. A parameter modification requires the drive to be switched off and on. Restart the drive to activate the parameter functionality. Check the parameter chapter for the parameter that required a restart of the drive.
E 110F	-	-	Function not available in this type of device The specific type of device does not support this function or this parameter value. Check if you have the correct device type, in particular type of motor, type of encoder, holding brake.
E 1300	3	4	Safety function STO activated The safety function STO was activated in "Operation enable" state. Reset the fault; check the wiring of the STO inputs.
E 1301	4	24	STO_A (PWRR_A) and STO_B (PWRR_B) different level The levels of the inputs STO_A (PWRR_A) and STO_B (PWRR_B) were different for more than 1 second. The drive has to be switched off and the reason fixed (e.g.: check emergency stop active) before it is switched on.
E 1312	-	-	Limit or reference switch signal in I/O functions not defined Reference movements require limit switches. These limit switches are not assigned to inputs. Assign the LIMP, LIMN and REF functions to the inputs.
E 2300	3	18	Power stage overcurrent Motor short circuit and deactivation of the power stage. Check the motor power connection.
E 3200	3	15	DC bus overvoltage Excessive regeneration during braking. Check deceleration ramp, check dimensioning of drive and braking resistor.

Error number	Class	Bit	Description, cause and correctives
E 3201	3	14	DC bus undervoltage (switch-off threshold) Power supply loss, poor power supply.
E 3202	2	14	DC bus undervoltage (Quick Stop threshold) Power supply loss, poor power supply.
E 4100	3	21	Power stage overtemperature Transistors overtemperature: ambient temperature is too high, fan is inoperative, dust. Remove the protective foil, improve the heat dissipation in the cabinet.
E 4101	0	1	Warning power stage overtemperature Transistors overtemperature: ambient temperature is too high, fan is inoperative, dust. Remove the protective foil, improve the heat dissipation in the cabinet.
E 4302	0	5	Motor overload (I2t) warning The current has exceeded the nominal value for an extended period of time.
E 610D	-	-	Error in selection parameter Wrong parameter value selected. Check the value to be written.
E 7328	4	19	Motor encoder sends: position capture errors Encoder signals internal position capturing fault. Contact technical support or replace the motor.
E 7329	0	8	Motor encoder sends: Warning EMC, encoder signals internal warning. Contact technical support or replace the motor.
E 7338	0	13	No valid motor absolute position Warning to inform you that absolute position has not yet been determined. Depending on application, fix the absolute position. Device still usable and all functions are OKAY.
E 7500	0	9	RS485/Modbus: overrun error EMC; cabling problem. Check cables.
E 7501	0	9	RS485/Modbus: framing error EMC; cabling problem. Check cables.
E 7502	0	9	RS485/Modbus: parity error EMC; cabling problem. Check cables.
E 7503	0	9	RS485/Modbus: receive error EMC; cabling problem. Check cables.

Error number	Class	Bit	Description, cause and correctives
E A300	-	-	Braking procedure after HALT request still active HALT was removed too soon. New command was sent before motor standstill was reached after a HALT request. Wait for complete stop before removing HALT signal. Wait until motor has come to a complete standstill.
E A301	-	-	Drive in state 'Quick Stop active' Error with error class 1 occurred. Drive stopped with Quick Stop command.
E A302	1	1	Interruption by LIMP LIMP was activated because working range was exceeded, misoperation of limit switch or signal disturbance. Check application. Check limit switch function and connection.
E A303	1	1	Interruption by LIMN LIMN was activated because working range was exceeded, misoperation of limit switch or signal disturbance. Check application. Check limit switch function and connection.
E A305	-	-	Power stage cannot be activated in the current operating state (state diagram) Fieldbus: trying to enable the power stage in operating state "Not ready to switch on". Refer to the state diagram in the operation chapter of the manual.
E A306	1	3	Interruption by user-initiated software stop Drive is in state "Quick Stop active" due to a software stop request. The activation of a new operating mode is not possible, the error code is sent as the response to the activation command. Clear break condition with command Fault Reset.
E A307	-	-	Interruption by internal software stop In homing and jog modes, the movement is internally interrupted using an internal software stop. The activation of a new operating mode is not possible, the error code is sent as the response to the activation command. Clear break condition with command Fault Reset.
E A308	-	-	Drive in state 'Fault' Error with error class 2 or higher occurred. Check error code (HMI or commissioning tool), remove error condition and clear error state with command Fault Reset.
E A309	-	-	Drive not in state 'Operation Enable' A command which requires the state "Operation enable" was sent (e.g.: opmode change). Set drive to state "OperationEnable" and repeat the command.
E A310	-	-	Power stage not active Command is not possible because the power stage is not enabled (state "Operation Enabled" or "Quick Stop"). Set drive to a state with the power stage enabled, refer to the state diagram in the operation chapter of the manual.

Error number	Class	Bit	Description, cause and correctives
E A313	-	-	Position overrun, reference point is therefore no longer defined (ref_ok=0) The position range limits were exceeded which resulted in a loss of the reference point. An absolute movement cannot be made until the definition of a new reference point. Define a new reference point by means of homing mode.
E A314	-	-	No reference position Command needs a defined reference point (ref_ok=1). Define a new reference point by means of homing mode.
E A315	-	-	Homing active Command not possible if homing is active. Wait until homing movement is finished.
E A317	-	-	Drive is not at standstill Command sent which is not allowed when the motor is not at a standstill e.g. - change of software limit switches - change of handling of monitoring signals - setting of reference point - teach in of data set Wait until motor has come to a standstill (x_end = 1).
E A318	-	-	Operating mode active (x_end=0) Activation of a new operating mode is not possible while the current operating mode is still active. Wait until the command in the operating mode has finished (x_end=1) or terminate current operating mode with HALT command.
E A319	1	2	Manual tuning/Autotuning: drive moved out of permissible range The motor exceeds the parameterized maximum allowed position range. Check allowed position range value and time interval.
E A31A	-	-	Manual tuning/Autotuning: amplitude/offset too high Amplitude plus offset for tuning exceed internal speed or current limitation. Choose lower amplitude and offset values.
E A31B	-	-	HALT requested Command not allowed while a HALT is requested. Clear HALT request and repeat command.
E A31C	-	-	Invalid position setting with software limit switch Value for negative (positive) software limit switch is greater (less) than value for positive (negative) software limit switch. Homing position value is set outside the range of the software limits. Set correct position values.
E A31D	-	-	Speed range overflow ('CTRL_n_max') The reference speed value was set to a value greater than the max. speed defined in 'CTRL_n_max'. Increase the value of 'CTRL_n_max' or reduce the reference speed value.
E A31E	1	2	Interruption by positive software limit switch Command not possible because of overtravel of positive software limit switch. Jog back to software limit range.

Error number	Class	Bit	Description, cause and correctives
E A31F	1	2	<p>Interruption by negative software limit switch</p> <p>Command not possible because of overrun of negative software limit switch.</p> <p>Jog back to software limit range.</p>
E A320	par.	22	<p>Tracking error too high</p> <p>External load or acceleration are too high.</p> <p>Reduce external load or acceleration, error response is adjustable via 'Flt_pDiff'.</p>
E A324	1	10	<p>Error during homing (additional info = detailed error number)</p> <p>Homing movement was stopped by an error, the detailed reason is indicated by the additional info in the error buffer.</p> <p>Possible sub error codes: EA325 EA326 EA327 EA328 EA329</p>
E A325	1	10	<p>Limit switch to be approached not enabled</p> <p>Homing to LIMP or LIMN and limit switches are disabled.</p> <p>Enable limit switch via 'IOsigLimP' or 'IOsigLimN'.</p>
E A326	1	10	<p>REF switch not found between LIMP and LIMN</p> <p>REF input switch defective or not correctly connected.</p> <p>Check the function and wiring of the REF switch.</p>
E A327	1	10	<p>Reference movement to REF without direction reversal, improper enabling of limit switch LIM</p> <p>Search of REF without direction reversal in positive (negative) direction with LIMP (LIMN) activated.</p> <p>Check the function and wiring of the LIMP (LIMN) switch.</p>
E A328	1	10	<p>Reference movement to REF without direction reversal, overrun of LIM or REF not permissible</p> <p>Search of REF without direction reversal and REF or LIM overtravel.</p> <p>Reduce homing speed ('HMn') or increase deceleration ('RAMPdecel'). Check the function and wiring of LIMP, LIMN and REF switch.</p>
E A329	1	10	<p>More than one signal LIMP/LIMN/REF active</p> <p>REF or LIM not connected correctly or supply voltage for switches too low.</p> <p>Check the wiring and 24VDC supply voltage.</p>
E A32A	1	10	<p>Ext. monitoring signal LIMP with neg. direction of rotation</p> <p>Start reference movement with neg. direction of rotation (e.g. reference movement to LIMN) and activate the LIMP switch (switch in opposite direction of movement).</p> <p>Check correct connection and function of limit switch. Activate a jog movement with negative direction of rotation (target limit switch must be connected to the inputs LIMN).</p>
E A32B	1	10	<p>Ext. monitoring signal LIMN with pos. direction of rotation</p> <p>Start reference movement with pos. direction of rotation (e.g. reference movement to LIMP) and activate the LIMN switch (switch in opposite direction of movement).</p> <p>Check correct connection and function of limit switch. Activate a jog movement with positive direction of rotation (target limit switch must be connected to the inputs LIMP).</p>

Error number	Class	Bit	Description, cause and correctives
E A32C	1	10	REF error (switch signal briefly enabled or switch overtraveled) Switch signal disturbance. Motor subjected to vibration or shock when stopped after activation of the switch signal. Check supply voltage, cabling and function of switch. Check motor reaction after stopping and optimize controller settings.
E A32D	1	10	LIMP error (switch signal briefly enabled or switch overtraveled) Switch signal disturbance. Motor subjected to vibration or shock when stopped after activation of the switch signal. Check supply voltage, cabling and function of switch. Check motor reaction after stopping and optimize controller settings.
E A32E	1	10	LIMN error (switch signal briefly enabled or switch overtraveled) Switch signal disturbance. Motor subjected to vibration or shock when stopped after activation of the switch signal. Check supply voltage, cabling and function of switch. Check motor reaction after stopping and optimize controller settings.
E A330	-	-	Reference movement to index pulse cannot be reproduced. Index pulse is too close to the switch The position difference between the change of the switch signal and the occurrence of the index pulse is too low. Change mounting point of limit switch (the optimum is a position one half of a motor revolution away from the current mechanical position, direction towards the outside of the working range).
E A332	1	10	Jog error (additional info = detailed error number) Jog movement was stopped by error. For additional info, check the detailed error number in the error buffer.
E A334	2	0	Timeout at Standstill window monitor Position deviation after movement finished greater than standstill window, e.g. caused by an external load. Check load. Check settings for standstill window ('STANDp_win', 'STANDpwinTime' and 'STANDpwinTout'). Optimize controller settings.
E A337	0	10	Operating mode cannot be continued Continuation of interrupted movement in profile position mode is not possible because another mode had been active in the meantime. In Motion Sequence mode, continuation is impossible if a motion blend was interrupted.
E A33A	-	-	Reference point is not defined (ref_ok=0) No homing done and no motor with absolute encoder connected. Homing position lost because the working position range was left. Start homing. Use motor with multiturn encoder if no homing is to be done.
E B100	0	9	RS485/Modbus: unknown service Unsupported Modbus service was received. Check application on the Modbus master.

Error number	Class	Bit	Description, cause and correctives
E B200	0	9	RS485/Modbus: Protocol error Logical protocol error: wrong length or unsupported subfunction. Check application on the Modbus master.
E B201	2	6	RS485/Modbus: Nodeguard error Modbus is defined as command interface ('DEVcmdinterf'=Modbus): connection monitoring parameter ('MBnode_guard') is <>0ms and a nodeguard event was detected. Check application on the Modbus master or change value (set to 0ms or increase the parameter 'MBnode_guard' monitoring time).
E B202	0	9	RS485/Modbus: Nodeguard warning Modbus is not defined as command interface ('DEVcmdinterf '<>Modbus): connection monitoring parameter ('MBnode_guard') is <>0ms and a nodeguard event was detected. Check application on the Modbus master or change (set to 0ms or increase the parameter 'MBnode_guard' monitoring time).
E B600	4	8	Ethernet module: Initialization error
E B601	1	8	Ethernet module: Realtime data error
E B602	0	14	Ethernet module: Realtime data warning
E B603	2	8	Ethernet module: Protocol-specific error
E B604	0	14	Ethernet module: Protocol-specific warning
E B605	2	8	Unknown error of Ethernet module.
E B607	0	14	Ethernet module is currently processing another request.
E B608	2	8	Ethernet module: Realtime Hot-Reset - an NMT Reset was sent while the drive was enabled - a Modbus TCP channel was reset while the drive was enabled
E B609	2	8	Ethernet module: Realtime Hot-Stop
E B60A	0	14	Ethernet module: Timeout in internal communication
E B60B	0	14	Ethernet module: Error in internal communication

11 Parameters

This chapter provides an overview of the parameters which can be used for operating the product.

▲ WARNING
UNINTENDED BEHAVIOR CAUSED BY PARAMETERS
The behavior of the drive system is governed by numerous parameters. Unsuitable parameter values can trigger unintended movements or signals or deactivate monitoring functions.
<ul style="list-style-type: none"> • Never change a parameters unless you understand its meaning. • Only start the system if there are no persons or obstructions in the hazardous area. • When commissioning, carefully run tests for all operating states and potential fault situations.
Failure to follow these instructions can result in death, serious injury or equipment damage.

11.1 Representation of the parameters

When parameters are explained, this contains, on the one hand, information which is needed for unique identification of a parameter. On the other hand, the parameter explanations can also provide information on settings, defaults and parameter properties.

Entering values

Note that the parameters are input in the fieldbus without decimal point. All decimal places must be entered.

Input examples:

Maximum value	Commissioning software	Fieldbus
2.0	2.0	20
23.57	23.57	2357
1,000	1,000	1000

11.1.1 Explanation of the parameter representation

A parameter explanation has the following features:

Parameter Name	Description	Unit Minimum value Default value Maximum value	Data type R/W persistent Expert	Parameter address via fieldbus
Example_Name	Brief description (cross-reference) Selection values 1 / Selection value1 : Explanation 1 2 / Selection value2 : Explanation 2 Further description and details	A _{pk} 0.00 3.00 300.00	UINT32 R/W per. -	Fieldbus 1234

The most important terms in the heading line of a parameter table are explained in the following.

- Parameter Name* The parameter name clearly identifies a parameter.
- Description* Brief description (cross-reference)
The brief description contains some information on the parameter and a cross-reference to the page that describes the function of the parameter.
Selection values
In the case of parameters which offer a selection of settings, the value to be entered via the fieldbus and the designation of the value for input via the commissioning software and the HMI are specified.
1 = Value via fieldbus
Selection value1 = Selection value via commissioning software
Further description and details
Provides further information on the parameter.
- Unit* The unit of the value.
- Minimum value* The minimum value which can be entered.
- Default value* Factory setting.
- Maximum value* The maximum value which can be entered.
- Data type* The data type determines the valid range of values, especially if minimum and maximum values are not explicitly indicated for a parameter.

Data type	Byte	Min value	Max value
INT8	1 Byte / 8 Bit	-128	127
UINT8	1 Byte / 8 Bit	0	255
INT16	2 Byte / 16 Bit	-32768	32767
UINT16	2 Byte / 16 Bit	0	65535
INT32	4 Byte / 32 Bit	-2147483648	2147483647
UINT32	4 Byte / 32 Bit	0	4294967295

- R/W* Indicates read and/or write values
"R/" values can only be read
"R/W" values can be read and written.

0198441113652, V2.00, 11.2008

- Persistent* "per." indicates whether the value of the parameter is persistent, i.e. whether it remains in the memory after the device is switched off . When changing a value via commissioning software or fieldbus, the user must explicitly store the changed value in the persistent memory.
- Parameter address* Each parameter has a unique parameter address. The parameter address is used to access the parameter via the fieldbus.

11.2 List of all parameters

Parameter Name	Description	Unit Minimum value Default value Maximum value	Data type R/W persistent Expert	Parameter address via fieldbus
_acc_pref	Acceleration of reference value generation Sign according to the changed speed value: Increased speed: pos. sign Reduced speed: neg. sign	min ⁻¹ /s - 0 -	INT32 R/- - -	Modbus 7954
_AccessInfo	Current access channel for action objects Low byte : 0 : Used by channel in high byte 1 : Exclusively used by channel in high byte High byte: Current assignment of access channel 0: reserved 1: IO 2: HMI 3: Modbus RS485 4: CANopen 5: CANopen via seconds SDO channel 6: Profibus 7: DeviceNet 8: reserved 9: Ethernet 10..15: Modbus TCP	- - 0 -	UINT16 R/- - -	Modbus 280
_actionStatus	Action word (158) Signal status: 0: not activated 1: activated Bit 0: Warning Bit 1: Error class 1 Bit 2: Error class 2 Bit 3: Error class 3 Bit 4: Error class 4 Bit 5: Reserved Bit 6: Drive is at standstill (<9 [1/min]) Bit 7: Drive rotates clockwise Bit 8: Drive rotates counter-clockwise Bit 9: Reserved Bit 10: Reserved Bit 11: Profile generator idle (reference speed is 0) Bit 12: Profile generator decelerates Bit 13: Profile generator accelerates Bit 14: Profile generator moves at constant speed Bit 15: Reserved	- - 0 -	UINT16 R/- - -	Modbus 7176
_DCOMopmd_act	Active operating mode (126) See DCOMopmode for coding	- -6 - 6	INT16 R/- - -	Modbus 6920

Parameter Name	Description	Unit Minimum value Default value Maximum value	Data type R/W persistent Expert	Parameter address via fieldbus
_ethMacAdr1	Ethernet MAC address part1 Bytes 1-2 of the MAC address (XX:XX :__:__:__) XX are the bytes used Example: MAC address: 11:22:33:44:55:66 The value stored in this case is 0x00001122	- - 0 -	UINT32 R/- - -	Modbus 6672
_ethMacAdr2	Ethernet MAC address part2 Bytes 3-6 of the MAC address (__:__:__ :XX:XX:XX:XX) XX are the bytes used Example: MAC address: 11:22:33:44:55:66 The value stored in this case is 0x33445566	- - 0 -	UINT32 R/- - -	Modbus 6674
_I2t_act_M	Current motor overload (156)	% - 0 -	INT16 R/- - -	Modbus 7218
_I2t_mean_M	Motor load (156)	% - 0 -	INT16 R/- - -	Modbus 7220
_Id_act	Actual motor current d-component In increments of 0.01A _{pk}	A _{pk} - 0.00 -	INT16 R/- - -	Modbus 7684
_Id_ref	Reference motor current d-component (weakening the field) In increments of 0.01A _{pk}	A _{pk} - 0.00 -	INT16 R/- - -	Modbus 7714
_Idq_act	Total motor current (vector sum d-compo- nents and q-components) In increments of 0.01A _{pk}	A _{pk} - 0.00 -	INT16 R/- - -	Modbus 7686
_IO_LIO_act	Status of digital inputs/outputs (96) Coding of the individual signals: Bit 0: LIO1 Bit 1: LIO2 ...	- - 0 -	UINT16 R/- - -	Modbus 2090
_IO_STO_con	Connection of STO inputs 0 / not available: Inputs not available 1 / not connected: Inputs available, but not connected (jumpered) 3 / connected: Inputs available and con- nected (safety function STO active) Inputs STO_A (PWRR_A) and STO_B (PWRR_B)	- 0 - 3	UINT16 R/- - -	Modbus 2088
_Iq_act	Actual motor current q-component In increments of 0.01A _{pk}	A _{pk} - 0.00 -	INT16 R/- - -	Modbus 7682

Parameter Name	Description	Unit Minimum value Default value Maximum value	Data type R/W persistent Expert	Parameter address via fieldbus
_lq_ref	Reference motor current q-component (generating torque) In increments of 0.01A _{pk}	A _{pk} - 0.00 -	INT16 R/- - -	Modbus 7712
_LastWarning	Last warning as number Number of the most recent warning. If the warning becomes inactive again, the number is memorized until the next fault reset. Value 0: No warning occurred	- - 0 -	UINT16 R/- - -	Modbus 7186
_n_act	Actual motor speed (137)	min ⁻¹ - 0 -	INT16 R/- - -	Modbus 7696
_n_actRAMP	Actual speed of motion profile generator (137)	min ⁻¹ - 0 -	INT32 R/- - -	Modbus 7948
_n_pref	Speed of reference value generation	min ⁻¹ - 0 -	INT32 R/- - -	Modbus 7950
_n_ref	Reference speed of speed controller	min ⁻¹ - 0 -	INT16 R/- - -	Modbus 7694
_n_targetRAMP	Reference speed of motion profile generator	min ⁻¹ - 0 -	INT32 R/- - -	Modbus 7946
_OpHours	Operating hours counter	s - 0 -	UINT32 R/- - -	Modbus 7188
_p_absENCusr	Motor position with reference to encoder range in user units (101) The value range is determined by the encoder type. In the case of singleturn encoders, the value refers to one motor revolution, in the case of multiturn encoders to the entire encoder range (e.g. 4096 revolutions). NOTE: The position is not valid until the absolute motor position has been determined. In the case of invalid absolute motor position: _WarnLatched _WarnActive Bit 13=1: Absolute motor position not yet captured	usr - 0 -	UINT32 R/- - -	Modbus 7710

Parameter Name	Description	Unit Minimum value Default value Maximum value	Data type R/W persistent Expert	Parameter address via fieldbus
_p_absmodulo	Absolute pos. with ref. to 1 motor revolution in internal units NOTE: The position is not valid until the absolute motor position has been determined. In the case of invalid absolute motor position: _WarnLatched _WarnActive Bit 13=1: Absolute motor position not yet captured	Inc - 0 -	UINT32 R/- - -	Modbus 7708
_p_act	Actual position of motor in internal units	Inc - 0 -	INT32 R/- - -	Modbus 7700
_p_actRAMPusr	Actual position of motion profile generator (135) In user units	usr - 0 -	INT32 R/- - -	Modbus 7940
_p_actusr	Actual motor position in user units (135)	usr - 0 -	INT32 R/- - -	Modbus 7706
_p_dif	Current deviation between reference and actual position (156) Corresponds to the current control deviation of the position controller.	revolution -214748.3648 - 214748.3647	INT32 R/- - -	Modbus 7716
_p_DifPeak	Value of the maximum tracking error of the position controller (156) The tracking error is the current position control deviation. See SPV_p_maxDiff for more information. A write access resets this value.	revolution 0.0000 - 429496.7295	UINT32 R/W - -	Modbus 4382
_p_ref	Reference position in internal units Value corresponds to the reference position of the position controller.	Inc - 0 -	INT32 R/- - -	Modbus 7698
_p_refusr	Reference position in user units (151) Value corresponds to the reference position of the position controller.	usr - 0 -	INT32 R/- - -	Modbus 7704
_p_tarRAMPusr	Target position of motion profile generator Absolute position value of the profile generator, calculated on the basis of the relative and absolute position values received. In user units	usr - 0 -	INT32 R/- - -	Modbus 7938
_prgNoCOM	Communication module program number Example: PR840.1 The value is entered as a decimal value: 8401	- - 0.0 -	UINT16 R/- - -	Modbus 6676

Parameter Name	Description	Unit Minimum value Default value Maximum value	Data type R/W persistent Expert	Parameter address via fieldbus
_prgNoDEV	Firmware program number Example: PR840.1 The value is entered as a decimal value: 8401	- - 0.0 -	UINT16 R/- - -	Modbus 258
_prgVerCOM	Communication module firmware version Example: V4.201 The value is entered as a decimal value: 4201	- - 0.000 -	UINT16 R/- - -	Modbus 6678
_prgVerDEV	Firmware version number Example: V4.201 The value is entered as a decimal value: 4201	- - 0.000 -	UINT16 R/- - -	Modbus 260
_serialNoDEV	Device serial number Serial number: unique number for identification of the product	- 0 - 4294967295	UINT32 R/- per. -	Modbus 302
_SigActive	Current status of monitoring signals (157) See _SigLatched for more details on the bit codes.	- - 0 -	UINT32 R/- - -	Modbus 7182

Parameter Name	Description	Unit Minimum value Default value Maximum value	Data type R/W persistent Expert	Parameter address via fieldbus
_SigLatched	<p>Saved status of monitoring signals (157)</p> <p>Signal status: 0: Not activated 1: Activated</p> <p>Bit assignments: Bit 0: General fault Bit 1: Limit switches (LIMP/LIMN/REF) Bit 2: Out of range (SW limit switches, tuning) Bit 3: Quickstop via fieldbus Bit 4: Inputs STO are 0 Bit 5: Reserved Bit 6: RS485 fault Bit 7: CAN fault Bit 8: Ethernet fault Bit 9: Frequency of reference signal too high Bit 10: Fault current operating mode Bit 11: Reserved Bit 12: Profibus fault Bit 13: Reserved Bit 14: Undervoltage DC bus Bit 15: Overvoltage DC bus Bit 16: Mains phase missing Bit 17: Motor connection fault Bit 18: Motor overcurrent/short circuit Bit 19: Motor encoder fault Bit 20: Undervoltage 24VDC Bit 21: Overtemperature (power stage, motor) Bit 22: Tracking error Bit 23: Max. speed exceeded Bit 24: Inputs STO different Bit 25: Reserved Bit 26: Reserved Bit 27: Reserved Bit 28: Reserved Bit 29: EEPROM fault Bit 30: System booting (Hardware fault or parameter error) Bit 31: System error (e.g. watchdog)</p> <p>Monitoring functions are product-dependent.</p>	- - 0 -	UINT32 R/- - -	Modbus 7184
_StopFault	Error number of last stop fault (158)	- - 0 -	UINT16 R/- - -	Modbus 7178
_Temp_act_PA	Power stage temperature (155)	°C - 0 -	INT16 R/- - -	Modbus 7200
_Ud_ref	Reference motor voltage d-component In increments of 0.1V	V - 0.0 -	INT16 R/- - -	Modbus 7690

Parameter Name	Description	Unit Minimum value Default value Maximum value	Data type R/W persistent Expert	Parameter address via fieldbus
AbsHomeRequest	Absolute positioning only after homing (134) 0 / no: No 1 / yes: Yes	- 0 0 1	UINT16 R/W per. -	Modbus 1580
AccessLock	Locking other access channels (115) 0: Release other access channels 1: Lock other access channels The fieldbus can lock active access to the device via the following access channels with this parameter: - Input signals - Commissioning software Processing of the input signal HALT cannot be locked.	- 0 - 1	UINT16 R/W - -	Modbus 316
BRK_release	Processing of holding brake (99) 0 / close: automatic processing (default) 1 / open: manual release of brake The brake output can only be activated in the states 'Switch on disabled' or 'Ready to switch on'. If the power stage is active, the value is automatically set to 0.	- 0 0 1	UINT16 R/W - -	Modbus 2068
BRK_status	Status of holding brake 0: closed 1: open 2: not available	- 0 0 2	UINT16 R/- - -	Modbus 2070
Cap1Activate	Capture unit 1 start/stop (170) 0 / Capture stop: Cancel capture function 1 / Capture once: Start one-time capture 2 / Capture continuous: Start continuous capture In the case of one-time capture, the function is terminated when the first value is captured. In the case of continuous capture, the function continues to run.	- 0 - 2	UINT16 R/W - -	Modbus 2568
Cap1Config	Capture unit 1 configuration (171) 0 / 1->0: Position capture at 1->0 change 1 / 0->1: Position capture at 0->1 change	- 0 0 1	UINT16 R/W - -	Modbus 2564
Cap1Count	Capture unit 1 event counter (171) Counts the capture events. The counter is reset when capture unit 1 is activated.	- - 0 -	UINT16 R/- - -	Modbus 2576
Cap1Pos	Capture unit 1 captured position (171) Captured position at the time of the "capture signal". The captured position is calculated again after "Position Setting" or "Homing".	usr - 0 -	INT32 R/- - -	Modbus 2572

Parameter Name	Description	Unit Minimum value Default value Maximum value	Data type R/W persistent Expert	Parameter address via fieldbus
Cap2Activate	Capture unit 2 start/stop (171) 0 / Capture stop: Cancel capture function 1 / Capture once: Start one-time capture 2 / Capture continuous: Start continuous capture In the case of one-time capture, the function is terminated when the first value is captured. In the case of continuous capture, the function continues to run.	- 0 - 2	UINT16 R/W - -	Modbus 2570
Cap2Config	Capture unit 2 configuration (171) 0 / 1->0: Position capture at 1->0 change 1 / 0->1: Position capture at 0->1 change	- 0 0 1	UINT16 R/W - -	Modbus 2566
Cap2Count	Capture unit 2 event counter (171) Counts the capture events. The counter is reset when capture unit 2 is activated.	- - 0 -	UINT16 R/- - -	Modbus 2578
Cap2Pos	Capture unit 2 captured position (171) Captured position at the time of the "capture signal". The captured position is calculated again after "Position Setting" or "Homing".	usr - 0 -	INT32 R/- - -	Modbus 2574
CapStatus	Status of the capture units (171) Read access: Bit 0: position capture via input CAP1 carried out Bit 1: position capture via input CAP2 carried out	- - 0 -	UINT16 R/- - -	Modbus 2562
CTRL_I_max	Current limitation (94) The value must not exceed the maximum permissible current of the motor or the power stage. Default: M_I_max	A _{pk} 0.00 - 299.99	UINT16 R/W per. -	Modbus 4610
CTRL_KFPp	Speed feed-forward control position controller Overshoot of up to 110% is possible.	% 0.0 100.0 110.0	UINT16 R/W per. -	Modbus 4624
CTRL_KPn	Speed controller P-term (106) The default value is calculated on the basis of the motor parameters.	A/min ⁻¹ 0.0001 - 1.2700	UINT16 R/W per. -	Modbus 4614
CTRL_KPp	Position controller P-term (111) The default value is calculated.	1/s 2.0 - 495.0	UINT16 R/W per. -	Modbus 4620

Parameter Name	Description	Unit Minimum value Default value Maximum value	Data type R/W persistent Expert	Parameter address via fieldbus
CTRL_n_max	Speed limitation (94) The set value must not exceed the maximum motor speed. Default: maximum motor speed (see M_n_max)	min ⁻¹ 0 - 13200	UINT16 R/W per. -	Modbus 4612
CTRL_Pcdamp	Damping Posicast filter speed The filter is switched off at a value of 1000.	% 50.0 100.0 100.0	UINT16 R/W per. expert	Modbus 4648
CTRL_Pcdelay	Time delay Posicast filter speed The filter is switched off at a value of 0.	ms 0.00 0.00 25.00	UINT16 R/W per. expert	Modbus 4650
CTRL_TAUref	Filter time constant ref.value filter of the ref. speed value (107)	ms 0.00 0.00 327.67	UINT16 R/W per. -	Modbus 4626
CTRL_TNn	Speed controller setting time (106)	ms 0.00 - 327.67	UINT16 R/W per. -	Modbus 4616
DCOMcompatib	DriveCom state machine: state transition from 3 to 4 0 / Automatic: Automatic (state transition is performed automatically) 1 / Drivecom-conform: Standard-compliant (state transition must be controlled via the fieldbus) Determines the state transition between the states SwitchOnDisabled (3) and Ready-ToSwitchOn (4) for CANopen devices. If the device is not CANopen, this value is ignored!	- 0 0 1	UINT16 R/W per. -	Modbus 6950
DCOMcontrol	Drivecom control word (123) Refer to chapter Operation, Operating States, for bit coding information. Bit 0: Switch on Bit 1: Enable Voltage Bit 2: Quick Stop Bit 3: Enable Operation Bit 4..6: Operating mode specific Bit 7: Fault Reset Bit 8: Halt Bit 9..15: Reserved (must be 0)	- - 0 -	UINT16 R/W - -	Modbus 6914
DCOMopmode	Operating mode (125) DS402 operating modes: 1: Profile position 3: Profile velocity 6: Homing ----- Manufacturer operating modes: -1: Jog	- -6 - 6	INT16 R/W - -	Modbus 6918

019844113652, V2.00, 11.2008

Parameter Name	Description	Unit Minimum value Default value Maximum value	Data type R/W persistent Expert	Parameter address via fieldbus
DCOMstatus	Drivecom status word (120) Refer to chapter Operation, State Machine for bit coding information. Bit 0-3,5,6: Status bits Bit 4: Voltage enabled Bit 7: Warning Bit 8: HALT request active Bit 9: Remote Bit 10: Target reached Bit 11: Reserved Bit 12: Operating mode specific Bit 13: x_err Bit 14: x_end Bit 15: ref_ok	- - 0 -	UINT16 R/- - -	Modbus 6916
ENC_pabsusr	Directly set the motor encoder position (102) The value set range depends on the encoder type. Singleturn encoder: 0 ... max_pos_usr/rev. - 1 Multiturn encoder: 0 ... (4096 * max_pos_usr/rev.) -1 max_pos_usr/rev.: maximum user position for one motor turn. This value is 16384 with the default scaling. NOTE: * If processing is to be performed with inversion of the direction of rotation, this must be set before the motor encoder position is adjusted. * The set value does not become active until the controller is switched on the next time. After the write access, a wait time of at least 1 second is required before the controller is switched off. * Changing this value also changes the position of the virtual index pulse and the index pulse for the ESIM function.	usr -2147483648 - 2147483647	INT32 R/W - -	Modbus 1324
EthErrBehv	Error behavior for realtime Ethernet data 0 / Warning: Warning (no error response) 1 / ErrorClass1: Error class 1 (Quick Stop) Sets the error class for incorrect realtime Ethernet data	- 0 0 1	UINT16 R/W per. -	Modbus 6412
EthFdrAutosave	Faulty Device Replacement (FDR) Autosave 0 / disabled: disabled 1 / 1 minute: 1 minute 2 / 5 minute: 5 minute 3 / 15 minute: 15 minute 4 / 30 minute: 30 minute 5 / 60 minute: 60 minute If FDR is enabled, the drive cyclically stores the configuration to the server in Autosave mode.	- 0 0 5	UINT16 R/W per. -	Modbus 6698

Parameter Name	Description	Unit Minimum value Default value Maximum value	Data type R/W persistent Expert	Parameter address via fieldbus
EthFdrEnable	Faulty Device Replacement (FDR) Enable 0 / disabled: disabled 1 / enabled: enabled Global setting to enable the FDR. If the device name is configured and this parameter is enabled, the drive gets the configuration from the FDR server.	- 0 0 1	UINT16 R/W per. -	Modbus 6696
EthGateway	Stored Ethernet network gateway Default is 192.168.100.254	- - 0 -	UINT32 R/W per. -	Modbus 6662
EthGatewayAct	Currently used Ethernet network gateway Default is 192.168.100.254	- - 0 -	UINT32 R/- - -	Modbus 6668
EthIpAddr	Stored IP address Default is 192.168.100.10	- - 0 -	UINT32 R/W per. -	Modbus 6658
EthIpAddrAct	Currently used IP address	- - 0 -	UINT32 R/- - -	Modbus 6664
EthIPConfInfo	IP configuration information 2000 / Device Name: Device Name 2001 / Bootp: Bootp 2002 / Stored: Stored in EEPROM 2003 / Build from MAC: Build from MAC 2004 / EtherNet/IP default: EtherNet/IP default 2005 / Powerlink: Powerlink 2006 / EtherCAT: EtherCAT The IP configuration can be set with the switches in the connector housing.	- 0 - 65535 - - -	UINT16 R/- - - -	Modbus 6694
EthSubMask	Stored subnet mask Default is 255.255.255.0	- - 0 -	UINT32 R/W per. -	Modbus 6660
EthSubMaskAct	Currently used subnet mask Default is 255.255.255.0	- - 0 -	UINT32 R/- - -	Modbus 6666
FLT_class	Error class (195) 0: Warning (no response) 1: Error (Quick Stop -> state 7) 2: Error (Quick Stop -> state 8, 9) 3: Fatal error (state 9, can be acknowledged) 4: Fatal error (state 9, cannot be acknowledged)	- 0 - 4 -	UINT16 R/- - -	Modbus 15364

Parameter Name	Description	Unit Minimum value Default value Maximum value	Data type R/W persistent Expert	Parameter address via fieldbus
FLT_del_err	Clear error memory (194) 1: Delete all entries in the error memory The clearing process is completed if a 0 is returned after a read access.	- 0 - 1	UINT16 R/W - -	Modbus 15112
FLT_err_num	Error number (195) Reading this parameter copies the entire error entry (error class, time of occurrence of error, ...) to an intermediate memory from which all elements of the error can then be read. In addition, the read pointer of the error memory is automatically set to the next error entry.	- 0 - 65535	UINT16 R/- - -	Modbus 15362
FLT_Idq	Motor current at error time In increments of 10mA	A - 0.00 -	UINT16 R/- - -	Modbus 15378
FLT_MemReset	Reset error memory read pointer (194) 1: Set error memory read pointer to oldest error entry.	- 0 - 1	UINT16 R/W - -	Modbus 15114
FLT_n	Speed at error time	min ⁻¹ - 0 -	INT16 R/- - -	Modbus 15376
FLT_powerOn	Number of power on cycles	- 0 - 4294967295	UINT32 R/- - -	Modbus 15108
FLT_Qual	Error additional information (195) This entry contains additional information on the error, depending on the error number. Example: a parameter address	- 0 - 65535	UINT16 R/- - -	Modbus 15368
FLT_Temp_DEV	Temperature of device at error time	°C - 0 -	INT16 R/- - -	Modbus 15382
FLT_Temp_PA	Temperature of power stage at error time	°C - 0 -	INT16 R/- - -	Modbus 15380
FLT_Time	Error time (195) With reference to operating hours counter	s 0 - 536870911	UINT32 R/- - -	Modbus 15366
FLT_UDC	DC bus voltage at error time In increments of 100mV	V - 0.0 -	UINT16 R/- - -	Modbus 15374

Parameter Name	Description	Unit Minimum value Default value Maximum value	Data type R/W persistent Expert	Parameter address via fieldbus
FLTAmpOnCyc	ENABLE cycles up to the time of error Number of power on cycles from the time the power supply (control voltage) was switched on to the time the error occurred.	- - 0 -	UINT16 R/- - -	Modbus 15370
FLTAmpOnTime	Time of error after ENABLE	s - 0 -	UINT16 R/- - -	Modbus 15372
HMdisREFtoIDX	Distance from switching edge to index pulse (146) This read value delivers the difference between the index pulse position and the position at the switching edge of the limit or reference switch. It allows to check the distance between the index pulse and the switching edge and serves as a criterion for determining whether the reference movement with index pulse processing can be reproduced. In increments of 1/10000 revolutions	revolution - 0.0000 -	INT32 R/- - -	Modbus 10264
HMdisusr	Distance from switching edge to reference point (143) After the drive 'leaves' the switch, it is positioned into the working area by a defined distance. This target point is defined as the reference point. The parameter is only effective during reference movements without index pulse search.	usr 1 200 2147483647	INT32 R/W per. -	Modbus 10254

Parameter Name	Description	Unit Minimum value Default value Maximum value	Data type R/W persistent Expert	Parameter address via fieldbus
HMmethod	<p>Homing method (140)</p> <p>1: LIMN with index pulse 2: LIMP with index pulse 7: REF+ with index pulse, inv., outside 8: REF+ with index pulse, inv., inside 9: REF+ with index pulse, not inv., inside 10: REF+ with index pulse, not inv., outside 11: REF- with index pulse, inv., outside 12: REF- with index pulse, inv., inside 13: REF- with index pulse, not inv., inside 14: REF- with index pulse, not inv., outside 17: LIMN 18: LIMP 23: REF+, inv., outside 24: REF+, inv., inside 25: REF+, not inv., inside 26: REF+, not inv., outside 27: REF-, inv., outside 28: REF-, inv., inside 29: REF-, not inv., inside 30: REF-, not inv., outside 33: Index pulse neg. direction 34: Index pulse pos. direction 35: Position setting</p> <p>Abbreviations: REF+: Search movement in pos. direction REF-: Search movement in pos. direction inv.: Invert direction in switch not inv.: Direction not inverted in switch outside: Index pulse / distance outside switch inside: Index pulse / distance inside switch</p>	- 1 18 35	INT16 R/W - -	Modbus 6936
HMn_out	<p>Speed of rotation for moving away from switch (141)</p> <p>The adjustable value is internally limited to the current parameter setting in RAMPn_max.</p>	min ⁻¹ 1 6 3000	UINT16 R/W per. -	Modbus 10250
HMn	<p>Speed of rotation for search of switch (141)</p> <p>The adjustable value is internally limited to the current parameter setting in RAMPn_max.</p>	min ⁻¹ 1 60 13200	UINT16 R/W per. -	Modbus 10248
HMoutdisusr	<p>Maximum distance for search for switching edge (142)</p> <p>0: Monitoring of distance inactive >0: Maximum distance in user-defined units</p> <p>After detection of the switch, the drive starts to search for the defined switching edge. If it is not found within the distance defined here, the reference movement is canceled with an error.</p>	usr 0 0 2147483647	INT32 R/W per. -	Modbus 10252
HMp_homeusr	<p>Position at reference point (141)</p> <p>After a successful reference movement, this position is automatically set at the reference point.</p>	usr -2147483648 0 2147483647	INT32 R/W per. -	Modbus 10262

Parameter Name	Description	Unit Minimum value Default value Maximum value	Data type R/W persistent Expert	Parameter address via fieldbus
HMp_setpusr	Position for position setting (151) Position setting position for homing method 35	usr - 0 -	INT32 R/W - -	Modbus 6956
HMSrchdisusr	Max. search distance after overrun of switch (142) 0: Search distance processing disabled >0: Search distance in user units The switch must be activated again within this search distance, otherwise the reference movement is canceled.	usr 0 0 2147483647	INT32 R/W per. -	Modbus 10266
IO_AutoEnable	Processing of power stage activation at PowerOn 0 / off: Active Enable during power on does not activate the power stage. 1 / on: Active Enable during power on activates the power stage. 2 / AutoOn: Power stage is automatically activated at power on.	- 0 0 2	UINT16 R/W per. -	Modbus 1292
IO_LO_set	Setting the digital outputs directly (176) Write access to output bits is only active if the signal pin is available as an output and if the function of the output was set to 'Available as required'. Coding of the individual signals: Bit 0: LO1_OUT Bit 1: LO2_OUT ...	- - 0 -	UINT16 R/W - -	Modbus 2082
IOfunct_LIO1	Function Input/Output LIO1 (177) 1 / Input Free available: Available as required 2 / Input Fault reset: Reset fault (local control mode only) 3 / Input Enable: Enable (local control mode only) 4 / Input Halt: Halt 9 / Input Jog positive: Jog positive 10 / Input Jog negative: Jog negative 11 / Input Jog fast/slow: Jog fast/slow 20 / Input Reference switch (REF): Reference switch (REF) 21 / Input Positive limit switch (LIMP): Positive limit switch (LIMP) 101 / Output Free available: Available as required 102 / Output No fault: No fault 103 / Output Active: Ready	- - 0 -	UINT16 R/W per. -	Modbus 1826

019844113652, V2.00, 11.2008

Parameter Name	Description	Unit Minimum value Default value Maximum value	Data type R/W persistent Expert	Parameter address via fieldbus
IOfunct_LIO2	Function Input/Output LIO2 (178)	-	UINT16	Modbus 1828
	1 / Input Free available: Available as required	0	R/W per.	
	2 / Input Fault reset: Reset fault (local control mode only)	-	-	
	3 / Input Enable: Enable (local control mode only)	-	-	
	4 / Input Halt: Halt	-	-	
	9 / Input Jog positive: Jog positive	-	-	
	10 / Input Jog negative: Jog negative	-	-	
	11 / Input Jog fast/slow: Jog fast/slow	-	-	
	20 / Input Reference switch (REF): Reference switch (REF)	-	-	
	22 / Input Negative limit switch (LIMN): Negative limit switch (LIMN)	-	-	
	101 / Output Free available: Available as required	-	-	
	102 / Output No fault: No fault	-	-	
	103 / Output Active: Ready	-	-	
IOfunct_LIO3	Function Input/Output LIO3 (178)	-	UINT16	Modbus 1830
	1 / Input Free available: Available as required	0	R/W per.	
	2 / Input Fault reset: Reset fault (local control mode only)	-	-	
	3 / Input Enable: Enable (local control mode only)	-	-	
	4 / Input Halt: Halt	-	-	
	9 / Input Jog positive: Jog positive	-	-	
	10 / Input Jog negative: Jog negative	-	-	
	11 / Input Jog fast/slow: Jog fast/slow	-	-	
	20 / Input Reference switch (REF): Reference switch (REF)	-	-	
	101 / Output Free available: Available as required	-	-	
	102 / Output No fault: No fault	-	-	
	103 / Output Active: Ready	-	-	
	IOfunct_LIO4	Function Input/Output LIO4 (178)	-	
1 / Input Free available: Available as required		0	R/W per.	
2 / Input Fault reset: Reset fault (local control mode only)		-	-	
3 / Input Enable: Enable (local control mode only)		-	-	
4 / Input Halt: Halt		-	-	
9 / Input Jog positive: Jog positive		-	-	
10 / Input Jog negative: Jog negative		-	-	
11 / Input Jog fast/slow: Jog fast/slow		-	-	
20 / Input Reference switch (REF): Reference switch (REF)		-	-	
101 / Output Free available: Available as required		-	-	
102 / Output No fault: No fault		-	-	
103 / Output Active: Ready		-	-	
IOsigLimN		Signal evaluation LIMN (141)	-	UINT16
	0 / inactive: Inactive	0	R/W	
	1 / normally closed: Normally closed NC	1	per.	
	2 / normally open: Normally open NO	2	-	

Parameter Name	Description	Unit Minimum value Default value Maximum value	Data type R/W persistent Expert	Parameter address via fieldbus
IOsigLimP	Signal evaluation LIMP (141) 0 / inactive: Inactive 1 / normally closed: Normally closed NC 2 / normally open: Normally open NO	- 0 1 2	UINT16 R/W per. -	Modbus 1568
IOsigRef	Signal evaluation REF (141) 1 / normally closed: Normally closed NC 2 / normally open: Normally open NO The reference switch is only activated (to REF) while homing is processed.	- 1 1 2	UINT16 R/W per. -	Modbus 1564
JOGactivate	Activation of jog (125) Bit 0: positive direction of rotation Bit 1: negative direction of rotation Bit 2: 0=slow 1=fast	- 0 0 7	UINT16 R/W - -	Modbus 6930
JOGn_fast	Speed for fast jog (128) The adjustable value is internally limited to the current parameter setting in RAMPn_max.	min ⁻¹ 1 180 13200	UINT16 R/W per. -	Modbus 10506
JOGn_slow	Speed for slow jog (128) The adjustable value is internally limited to the current parameter setting in RAMPn_max.	min ⁻¹ 1 60 13200	UINT16 R/W per. -	Modbus 10504
JOGstepusr	Jog distance prior to continuous run (128) 0: Direct activation of continuous run >0: Positioning distance per jog cycle	usr 0 20 2147483647	INT32 R/W per. -	Modbus 10510
JOGtime	Wait time prior to continuous run (128) This time is only effective if you have set a jog distance not equal to 0, otherwise the drive immediately starts a continuous run.	ms 1 500 32767	UINT16 R/W per. -	Modbus 10512
LIM_HaltReaction	Type of deceleration for halt (168) 1 / Deceleration ramp: Deceleration ramp 3 / Torque ramp: Torque ramp Setting of deceleration ramp with parameter RAMPdecel. Setting of torque ramp with parameter LIM_I_maxHalt. The deceleration ramp is only available for operating modes with profile generator. The torque ramp is used in the operating modes without profile generator.	- 1 3 3	INT16 R/W per. -	Modbus 1582
LIM_I_maxHalt	Current limitation for Halt (94) Max. current during braking after Halt or when an operating mode is terminated. Maximum and default settings depend on the motor and the power stage (settings M_I_max and PA_I_max) In increments of 0.01A _{pk}	A _{pk} - - -	UINT16 R/W per. -	Modbus 4364

Parameter Name	Description	Unit Minimum value Default value Maximum value	Data type R/W persistent Expert	Parameter address via fieldbus
LIM_I_maxQSTP	Current limitation for Quick Stop (94) Max. current during braking via torque ramp due to an error of error classes 1 or 2 and when a software stop is triggered. Maximum and default settings depend on the motor and the power stage (settings M_I_max and PA_I_max) In increments of 0.01A _{pk}	A _{pk} - - -	UINT16 R/W per. -	Modbus 4362
LIM_QStopReact	Type of deceleration for Quick Stop (166) 6 / Deceleration ramp: Deceleration ramp 7 / Torque ramp: Torque ramp Setting of deceleration ramp with parameter RAMPquickstop. Setting of torque ramp with parameter LIM_I_maxQSTP. The deceleration ramp is only available for operating modes with profile generator. The torque ramp is used in the operating modes without profile generator.	- 6 7 7	INT16 R/W per. -	Modbus 1584
M_I_0	Continuous motor current at standstill In increments of 0.01A _{pk}	A _{pk} - - -	UINT16 R/- - -	Modbus 3366
M_I_max	Maximum motor current In increments of 0.01A _{pk}	A _{pk} - - -	UINT16 R/- - -	Modbus 3340
M_I_nom	Nominal motor current In increments of 0.01A _{pk}	A _{pk} - - -	UINT16 R/- - -	Modbus 3342
M_I2t	Maximum permissible time for M_I_max	ms - - -	UINT16 R/- - -	Modbus 3362
M_Jrot	Mass moment of inertia of motor In increments of 0.1kgcm ²	kg cm ² - - -	UINT16 R/- - -	Modbus 3352
M_kE	Motor EMF constant kE Voltage constant in V _{pk} at 1000 1/min	- - - -	UINT16 R/- - -	Modbus 3350
M_L_d	Motor inductance d-direction In increments of 0.01 mH	mH - - -	UINT16 R/- - -	Modbus 3358
M_L_q	Motor inductance q-direction In increments of 0.01 mH	mH - - -	UINT16 R/- - -	Modbus 3356

Parameter Name	Description	Unit Minimum value Default value Maximum value	Data type R/W persistent Expert	Parameter address via fieldbus
M_M_max	Maximum motor torque	N cm - - -	UINT16 R/- - -	Modbus 3346
M_M_nom	Nominal motor torque	N cm - - -	UINT16 R/- - -	Modbus 3344
M_n_max	Maximum permissible motor speed	min ⁻¹ - - -	UINT16 R/- - -	Modbus 3336
M_n_nom	Nominal motor speed	min ⁻¹ - - -	UINT16 R/- - -	Modbus 3338
M_Polepair	Number of pole pairs of motor	- - - -	UINT16 R/- - -	Modbus 3368
M_R_UV	Motor connection resistance In increments of 10mOhm	Ω - - -	UINT16 R/- - -	Modbus 3354
M_U_nom	Nominal motor voltage Voltage in increments of 100mV	V - - -	UINT16 R/- - -	Modbus 3348
MBadr	Modbus address Valid addresses: 1 to 247	- 1 1 247	UINT16 R/W per. -	Modbus 5640
MBbaud	Modbus Baud rate 9600 / 9.6KB : 9600 Baud 19200 / 19.2KB : 19200 Baud 38400 / 38.4KB : 38400 Baud NOTE: Changed settings do not become active until the unit is switched on the next time	- 9600 19200 38400	UINT16 R/W per. -	Modbus 5638
MBdword_order	Modbus word sequence for double words (32 bit values) 0 / HighLow : HighWord-LowWord 1 / LowHigh : LowWord-HighWord High word first or low word first High word first -> Modicon Quantum Low word first -> Premium, HMI (Telemecanique)	- 0 0 1	UINT16 R/W per. -	Modbus 5646

Parameter Name	Description	Unit Minimum value Default value Maximum value	Data type R/W persistent Expert	Parameter address via fieldbus
MBformat	Modbus data format 1 / 8Bit NoParity 1Stop : 8 bits, no parity bit, 1 stop bit 2 / 8Bit EvenParity 1Stop : 8 bits, even parity bit, 1 stop bit 3 / 8Bit OddParity 1Stop : 8 bits, odd parity bit, 1 stop bit 4 / 8Bit NoParity 2Stop : 8 bits, no parity bit, 2 stop bits NOTE: Changed settings do not become active until the unit is switched on the next time	- 1 2 4	UINT16 R/W per. -	Modbus 5642
MBnode_guard	Modbus node guard (91) Node guard 0: Inactive (default) >0: Monitoring time	ms 0 0 10000	UINT16 R/W - -	Modbus 5644
MBscan_guard	ModbusTCP node guard for I/O scanning (91) 0: Inactive (default) >0: Monitoring time in ms The drive starts monitoring when it receives the first I/O scanning message. After a node guarding error the drive starts monitoring again when it receives the next I/O scanning message.	ms 0 0 10000	UINT16 R/W - -	Modbus 6414
MBTCPdword_order	ModbusTCP word sequence for double words (32 bit values) 0 / HighLow : HighWord-LowWord 1 / LowHigh : LowWord-HighWord High word first or low word first High word first -> Modicon Quantum Low word first -> Premium, HMI (Telemecanique)	- 0 0 1	UINT16 R/W per. -	Modbus 6410
MT_dismax	Max. permissible distance If the reference value is active and the maximum permissible distance is exceeded, an error of class 1 is generated. The value 0 switches off monitoring.	revolution 0.0 1.0 999.9	UINT16 R/W - -	Modbus 11782
PA_T_max	Maximum permissible power stage temperature (155)	°C - 0 -	INT16 R/- per. -	Modbus 4110
PA_T_warn	Temperature warning threshold of power stage (155)	°C - 0 -	INT16 R/- per. -	Modbus 4108
PA_U_maxDC	Maximum permissible DC bus voltage Voltage in increments of 100mV	V - - -	UINT16 R/- per. -	Modbus 4102

Parameter Name	Description	Unit Minimum value Default value Maximum value	Data type R/W persistent Expert	Parameter address via fieldbus
PA_U_minDC	DC bus voltage low threshold for switching off the drive Voltage in increments of 100mV	V - - -	UINT16 R/- per. -	Modbus 4104
PA_U_minStopDC	DC bus voltage low threshold for Quick Stop If this threshold is reached, the drive performs a Quick Stop. Voltage in increments of 100mV	V - - -	UINT16 R/- per. -	Modbus 4116
PAR_CTRLreset	Reset controller parameters 0 / no: No 1 / yes: Yes The controller parameters of the speed controller and the position controller are reset. The current controller is automatically adjusted under consideration of the connected motor.	- 0 - 1	UINT16 R/W - -	Modbus 1038
PAReprSave	Save parameter values to EEPROM Bit 0 = 1: Save all persistent parameters The currently set parameters are saved to the non-volatile memory (EEPROM). The saving process is complete when the parameter is read and 0 is returned.	- - - -	UINT16 R/W - -	Modbus 1026
PARfactorySet	Restore factory settings (default values) 0 / No: No 1 / Yes: Yes All parameters are set to their default values, these are saved to the EEPROM. Restoring the factory settings is only possible via the commissioning software. The saving process is complete when the parameter is read and 0 is returned. NOTE: The default becomes active only when the unit is switched on the next time.	- 0 - 3	R/W - -	
PARuserReset	Reset user parameters (181) Bit 0 = 1: Set persistent parameters to default values. All parameters are reset with the exception of: - Communication parameters - Definition of the direction of rotation - Signal selection position interface - I/O functions NOTE: The new settings are not saved to the EEPROM!	- 0 - 7	UINT16 R/W - -	Modbus 1040

Parameter Name	Description	Unit Minimum value Default value Maximum value	Data type R/W persistent Expert	Parameter address via fieldbus
POSdirOfRotat	<p>Definition of direction of rotation (179)</p> <p>0 / clockwise: Clockwise 1 / counter clockwise: Counter-clockwise</p> <p>Meaning: At positive speeds, the drive rotates clockwise (looking at the motor shaft at the flange).</p> <p>NOTE: If you use limit switches, you must interchange the limit switch connections after changing the settings. The limit switch which is reached with a jog movement in positive direction must be connected to the LIMP input and vice versa.</p> <p>NOTE: Changed settings do not become active until the unit is switched on the next time.</p>	- 0 0 1	UINT16 R/W per. -	Modbus 1560
POSscaleDenom	<p>Denominator of position scaling (161)</p> <p>Refer to numerator (POSscaleNum) for a description.</p> <p>A new scaling is activated when the numerator value is supplied.</p>	usr 1 16384 2147483647	INT32 R/W per. -	Modbus 1550
POSscaleNum	<p>Numerator of position scaling (161)</p> <p>Specification of the scaling factor:</p> <p>Motor revolutions [U] ----- Change of user position [usr]</p> <p>A new scaling is activated when the numerator value is supplied.</p> <p>User limit values may be reduced due to the calculation of an internal factor.</p>	revolution 1 1 2147483647	INT32 R/W per. -	Modbus 1552
PPn_target	<p>Reference speed in operating mode profile position (134)</p> <p>The maximum value is limited to the current setting in CTRL_n_max.</p> <p>The adjusted value is internally limited to the current parameter value in RAMPn_max.</p>	min ⁻¹ 1 60 -	UINT32 R/W - -	Modbus 6942
PPoption	<p>Options for operating mode profile position (134)</p> <p>Determines the reference position for relative positioning: 0: Relative with reference to the previous target position of the motion profile generator 1: Not supported 2: Relative with reference to the actual position of the motor</p>	- 0 0 2	UINT16 R/W - -	Modbus 6960

Parameter Name	Description	Unit Minimum value Default value Maximum value	Data type R/W persistent Expert	Parameter address via fieldbus
PPp_targetusr	Target position in operating mode profile position (134) Min./max values depend on: - Scaling factor - Software limit switches (if they are activated)	usr - 0 -	INT32 R/W - -	Modbus 6940
ProfileType	Motion profile 0: Linear	- 0 0 0	INT16 R/W - -	Modbus 6954
PVn_target	Reference speed in operating mode profile velocity (137) The maximum value is limited to the current setting in CTRL_n_max. The adjusted value is internally limited to the current parameter value in RAMPn_max.	min ⁻¹ - 0 -	INT32 R/W - -	Modbus 6938
RAMP_TAUjerk	Jerk limitation (129) 0 / off: Off 1 / 1: 1 ms 2 / 2: 2 ms 4 / 4: 4 ms 8 / 8: 8 ms 16 / 16: 16 ms 32 / 32: 32 ms 64 / 64: 64 ms 128 / 128: 128 ms Limits the acceleration change (jerk) of the reference position generation during the positioning transitions: Standstill - acceleration Acceleration - constant speed Constant speed - deceleration Deceleration - standstill Processing in the following operating modes: - Profile velocity - Profile position - Jog - Homing Adjustments can only be made if the operating mode is inactive (x_end=1).	ms 0 0 128	UINT16 R/W per. -	Modbus 1562
RAMPacc	Acceleration of profile generator (129)	min ⁻¹ /s 1 600 3000000	UINT32 R/W per. -	Modbus 1556
RAMPdecel	Deceleration of profile generator (129)	min ⁻¹ /s 750 750 3000000	UINT32 R/W per. -	Modbus 1558

Parameter Name	Description	Unit Minimum value Default value Maximum value	Data type R/W persistent Expert	Parameter address via fieldbus
RAMPn_max	<p>Limitation of ref. speed for op. modes with profile generation (95)</p> <p>The parameter is active in the following operating modes:</p> <ul style="list-style-type: none"> - Profile position - Profile velocity - Homing - Jog <p>If a greater reference speed is set in one of these operating modes, it is automatically limited to RAMPn_max. This way, commissioning at limited speed is easy to perform.</p>	min ⁻¹ 60 13200 13200	UINT16 R/W per. -	Modbus 1554
RAMPquickstop	<p>Deceleration ramp for Quick Stop (167)</p> <p>Deceleration of the drive when a software stop is triggered or if an error of error class 1 has occurred.</p>	min ⁻¹ /s 200 6000 3000000	UINT32 R/W per. -	Modbus 1572
RAMPsym	<p>Symmetrical ramp</p> <p>Acceleration and deceleration of the profile generator (16 bit value) in 10 (1/min)/s</p> <p>Write access changes the values under RAMPacc and RAMPdecel. The limit values are checked on the basis of the values indicated for these parameters.</p> <p>Read access returns the greater value from RAMPacc/RAMPdecel. If the currently set value cannot be represented as 16 bit value, the max, UINT16 value is written.</p>	usr - 0 -	UINT16 R/W - -	Modbus 1538
SPEEDn_target	<p>Reference speed in operating mode speed control (131)</p> <p>The internal maximum speed is limited to the current setting in CTRL_n_max.</p>	min ⁻¹ -30000 0 30000	INT16 R/W - -	Modbus 8456
SPEEDreference	<p>Selection of the ref. value source for op. mode speed control (131)</p> <p>0 / none: None 2 / Parameter 'speedTarg': Reference value via parameter SPEEDn_target</p>	- 0 0 2	UINT16 R/W - -	Modbus 6946
SPV_Flt_pDiff	<p>Error response to tracking error (159)</p> <p>1 / ErrorClass1: Error class 1 2 / ErrorClass2: Error class 2 3 / ErrorClass3: Error class 3</p>	- 1 3 3	UINT16 R/W per. -	Modbus 1302
SPV_p_maxDiff	<p>Max. permissible tracking error of the position controller (156)</p> <p>The tracking error is the current position control deviation.</p>	revolution 0.0001 1.0000 200.0000	UINT32 R/W per. -	Modbus 4636

Parameter Name	Description	Unit Minimum value Default value Maximum value	Data type R/W persistent Expert	Parameter address via fieldbus
SPV_SW_Limits	Monitoring of software limit switches (154) 0 / none: None (default) 1 / SWLIMP: Activation of software limit switches positive direction 2 / SWLIMN: Activation of software limit switches negative direction 3 / SWLIMP+SWLIMN: Activation of software limit switches both directions Monitoring of software limit switches only works in case of successful homing (ref_ok = 1).	- 0 0 3	UINT16 R/W per. -	Modbus 1542
SPVswLimNusr	Negative position limit for software limit switch (153) Refer to description 'SPVswLimPusr'	usr - -2147483648 -	INT32 R/W per. -	Modbus 1546
SPVswLimPusr	Positive position limit for software limit switch (153) If a user value entered is outside of the permissible user range, the limit switch limits are automatically set to the max. user value.	usr - 2147483647 -	INT32 R/W per. -	Modbus 1544
STANDp_win	Standstill window, permissible control deviation (172) The control deviation for the standstill window time must be within this range for a standstill of the drive to be detected. Processing of the standstill window must be activated via the parameter 'STANDpwinTime'.	revolution 0.0000 0.0010 3.2767	UINT16 R/W per. -	Modbus 4370
STANDpwinTime	Standstill window, time (172) 0: Monitoring of standstill window deactivated >0: Time in ms during which the control deviation must be in the standstill window	ms 0 0 32767	UINT16 R/W per. -	Modbus 4372
STANDpwinTout	Timeout time for standstill window monitoring (172) 0 : Timeout monitoring deactivated >0 : Timeout time in ms Standstill window processing values are set via STANDp_win und STANDpwinTime. Time monitoring starts when the target position (reference position of position controller) is reached or when the profile generator has finished processing.	ms 0 0 16000	UINT16 R/W per. -	Modbus 4374

Parameter Name	Description	Unit Minimum value Default value Maximum value	Data type R/W persistent Expert	Parameter address via fieldbus
SuppDriveModes	Supported operating modes as per DSP402 Coding: Bit 0: Profile position Bit 2: Profile velocity Bit 5: Homing Bit 16: Jog Bit 17: Electronic gear Bit 18: Current control Bit 19: Speed control Bit 20: Position control Bit 21: Manual tuning Bit 22: Oscillator mode The availability of the individual bits is product-dependent.	- - 0 -	UINT32 R/- - -	Modbus 6952

12 Accessories and spare parts

12.1 Accessories

Source commissioning software The latest version of the commissioning software is available for download from the internet:

<http://www.schneider-electric.com>

Source EPLAN Macros For easier engineering, macro files and product master data are available for download from the Internet at:

<http://www.schneider-electric.com>

Designation	Order no.
Braking Resistor Controller UBC60	ACC3EA001
Installation kit	VW3L10111
Insert with cable entry (2 pcs)	VW3L10100N2
Insert with cable entry (10 pcs)	VW3L10100N10
Cable entry for commissioning	VW3L10222
Insert for sealing (10 pcs)	VW3L10000N10
Insert for sealing (20 pcs)	VW3L10000N20
Insert for sealing (50 pcs)	VW3L10000N50
Cable for commissioning interface, 3m	VW3L1R000R30
Insert kit for commissioning	VW3L1R000
Cable kit, power supply, Modbus TCP, 3m	VW3L2T001R30
Cable kit, STO, 3m	VW3L20010R30
Cable kit, STO, 5m	VW3L20010R50
Cable kit, STO, 10m	VW3L20010R100
Cable kit, STO, 15m	VW3L20010R150
Cable kit, STO, 20m	VW3L20010R200
Cable, power supply, 3m	VW3L30001R30
Cable, power supply, 5m	VW3L30001R50
Cable, power supply, 10m	VW3L30001R100
Cable, power supply, 15m	VW3L30001R150
Cable, power supply, 20m	VW3L30001R200
Cable, STO, 3m	VW3L30010R30
Cable, STO, 5m	VW3L30010R50
Cable, STO, 10m	VW3L30010R100
Cable, STO, 15m	VW3L30010R150
Cable, STO, 20m	VW3L30010R200
Connector, Modbus TCP	VW3L5T000
Connector kit, 2 x I/O	VW3L50200
Connector kit, 3 x I/O	VW3L50300
Connector, STO output	VW3L50010

Designation	Order no.
Insert kit, 3 x I/O	VW3L40300
Insert kit, 2 x I/O, 1 x STO input	VW3L40210
Insert kit, 1 x STO input, 1 x STO output	VW3L40020
Insert kit, 4 x I/O, 1 x STO input, 1 x STO output	VW3L40420

Cable Supplier recommendations:

- Hans Turck GmbH & Co. KG
www.turck.com
- Franz Binder GmbH & Co. elektrische Bauelemente KG
www.binder-connector.de
- PHOENIX CONTACT GmbH & Co. KG
www.phoenixcontact.com
- Lumberg Automation
www.lumberg-automation.com

Tool The tools required for cable assembly must be ordered directly from the manufacturer.

- Crimping tool for CN1: AMP 654174-1
- Crimping tool for CN2, CN4 and CN5: Molex 69008-0982
- Crimping tool for CN3: Molex 69008-0724
- Extraction tool for CN2, CN4 and CN5: Molex 11-03-0043
- Extraction tool for CN3: Molex 11-03-0044

12.2 Gearboxes

Designation	Order no.
Planetary gear for Lexium Integrated Drive ILAxx571, ratio 3/1	GBX060003A571L
Planetary gear for Lexium Integrated Drive ILAxx571, ratio 5/1	GBX060005A571L
Planetary gear for Lexium Integrated Drive ILAxx571, ratio 8/1	GBX060008A571L
Planetary gear for Lexium Integrated Drive ILAxx571, ratio 16/1	GBX060016A571L
Planetary gear for Lexium Integrated Drive ILAxx571, ratio 40/1	GBX060040A571L
Planetary gear for Lexium Integrated Drive ILAxx572, ratio 3/1	GBX060003A572L
Planetary gear for Lexium Integrated Drive ILAxx572, ratio 5/1	GBX060005A572L
Planetary gear for Lexium Integrated Drive ILAxx572, ratio 8/1	GBX060008A572L
Planetary gear for Lexium Integrated Drive ILAxx572, ratio 16/1	GBX060016A572L
Planetary gear for Lexium Integrated Drive ILAxx572, ratio 40/1	GBX060040A572L

13 Service, maintenance and disposal

⚠ WARNING

DAMAGE TO SYSTEM COMPONENTS AND LOSS OF CONTROL

Interruptions of the negative connection of the controller supply voltage can cause excessively high voltages at the signal connections.

- Do not interrupt the negative connection between the power supply unit and load with a fuse or switch.
- Verify correct connection before switching on.
- Do not connect the controller supply voltage or change its wiring while the is supply voltage present.

Failure to follow these instructions can result in death, serious injury or equipment damage.

⚠ CAUTION

RISK OF INJURY WHEN THE PRINTED CIRCUIT BOARD CONNECTORS ARE REMOVED

- Before removing the connectors, you must unlocked them.
 - Supply voltage ∇ DC:
Unlock by pulling at the connector housing
 - Others:
Unlock by pressing the connector lock
- Only pull the connector housing (not the cable).

Failure to follow these instructions can result in injury or equipment damage.



The product may only be repaired by a certified customer service center. No warranty or liability is accepted for repairs made by unauthorized persons.

13.1 Service address

If you cannot resolve an error yourself please contact your sales office. Have the following details available:

- Nameplate (type, identification number, serial number, DOM, ...)
- Type of error (such as LED flash code or error number)
- Previous and concomitant circumstances
- Your own assumptions concerning the cause of the error

Also include this information if you return the product for inspection or repair.



If you have any questions please contact your sales office. Your sales office staff will be happy to give you the name of a customer service office in your area.

<http://www.schneider-electric.com>

13.2 Maintenance

Check the product for pollution or damage at regular intervals.

13.2.1 Lifetime STO safety function

The STO safety function is designed for a lifetime of 20 years. After this period, the data of the safety function are no longer valid. The expiry date is determined by adding 20 years to the DOM shown on the nameplate of the product.

- ▶ This date must be included in the maintenance plan of the system.

Do not use the safety function after this date.

Example The DOM on the nameplate of the product is shown in the format DD.MM.YY, for example 31.12.07 . (December 31, 2007). This means: Do not use the safety function after December 31, 2027.

13.3 Replacing units

⚠ WARNING

UNINTENDED BEHAVIOR

The behavior of the drive system is governed by numerous stored data or settings. Unsuitable settings or data may trigger unexpected movements or responses to signals and disable monitoring functions.

- Do NOT operate the drive system with unknown settings or data.
- Verify that the stored data and settings are correct.
- When commissioning, carefully run tests for all operating states and potential fault situations.
- Verify the functions after replacing the product and also after making changes to the settings or data.
- Only start the system if there are no persons or obstructions in the hazardous area.

Failure to follow these instructions can result in death, serious injury or equipment damage.



Prepare a list with the parameters required for the functions used.

Observe the following procedure when replacing devices.

- ▶ Save all parameter settings to your PC using the commissioning software, see chapter 7.2.4 "Lexium CT commissioning software".
- ▶ Switch off all supply voltages. Verify that no voltages are present (safety instructions).
- ▶ Label all connections and uninstall the product.
- ▶ Note the identification number and the serial number shown on the product nameplate for later identification.
- ▶ Install the new product as per chapter 6 "Installation".
- ▶ Commission the product as per chapter 7 "Commissioning".

13.4 Shipping, storage, disposal

Note the ambient conditions in chapter 3.2 "Ambient conditions".

- Shipping* The product must be protected against shocks during transportation. If possible, use the original packaging for shipping.
- Storage* The product may only be stored in spaces where the specified permissible ambient conditions for room temperature and humidity are met. Protect the product from dust and dirt.
- Disposal* The product consists of various materials that can be recycled and must be disposed of separately. Dispose of the product in accordance with local regulations.

14 Glossary

14.1 Units and conversion tables

The value in the specified unit (left column) is calculated for the desired unit (top row) with the formula (in the field).

Example: conversion of 5 meters [m] to yards [yd]
 $5 \text{ m} / 0.9144 = 5.468 \text{ yd}$

14.1.1 Length

	in	ft	yd	m	cm	mm
in	-	/ 12	/ 36	* 0.0254	* 2.54	* 25.4
ft	* 12	-	/ 3	* 0.30479	* 30.479	* 304.79
yd	* 36	* 3	-	* 0.9144	* 91.44	* 914.4
m	/ 0.0254	/ 0.30479	/ 0.9144	-	* 100	* 1000
cm	/ 2.54	/ 30.479	/ 91.44	/ 100	-	* 10
mm	/ 25.4	/ 304.79	/ 914.4	/ 1000	/ 10	-

14.1.2 Mass

	lb	oz	slug	kg	g
lb	-	* 16	* 0.03108095	* 0.4535924	* 453.5924
oz	/ 16	-	* $1.942559 \cdot 10^{-3}$	* 0.02834952	* 28.34952
slug	/ 0.03108095	/ $1.942559 \cdot 10^{-3}$	-	* 14.5939	* 14593.9
kg	/ 0.45359237	/ 0.02834952	/ 14.5939	-	* 1000
g	/ 453.59237	/ 28.34952	/ 14593.9	/ 1000	-

14.1.3 Force

	lb	oz	p	dyne	N
lb	-	* 16	* 453.55358	* 444822.2	* 4.448222
oz	/ 16	-	* 28.349524	* 27801	* 0.27801
p	/ 453.55358	/ 28.349524	-	* 980.7	* $9.807 \cdot 10^{-3}$
dyne	/ 444822.2	/ 27801	/ 980.7	-	/ $100 \cdot 10^3$
N	/ 4.448222	/ 0.27801	/ $9.807 \cdot 10^{-3}$	* $100 \cdot 10^3$	-

14.1.4 Power

	HP	W
HP	-	* 746
W	/ 746	-

14.1.5 Rotation

	min ⁻¹ (RPM)	rad/s	deg./s
min ⁻¹ (RPM) -		* $\pi / 30$	* 6
rad/s	* $30 / \pi$	-	* 57.295
deg./s	/ 6	/ 57.295	-

14.1.6 Torque

	lb-in	lb-ft	oz-in	Nm	kp-m	kp-cm	dyne-cm
lb-in	-	/ 12	* 16	* 0.112985	* 0.011521	* 1.1521	* 1.129×10^6
lb-ft	* 12	-	* 192	* 1.355822	* 0.138255	* 13.8255	* 13.558×10^6
oz-in	/ 16	/ 192	-	* 7.0616×10^{-3}	* 720.07×10^{-6}	* 72.007×10^{-3}	* 70615.5
Nm	/ 0.112985	/ 1.355822	/ 7.0616×10^{-3}	-	* 0.101972	* 10.1972	* 10×10^6
kp-m	/ 0.011521	/ 0.138255	/ 720.07×10^{-6}	/ 0.101972	-	* 100	* 98.066×10^6
kp-cm	/ 1.1521	/ 13.8255	/ 72.007×10^{-3}	/ 10.1972	/ 100	-	* 0.9806×10^6
dyne-cm	/ 1.129×10^6	/ 13.558×10^6	/ 70615.5	/ 10×10^6	/ 98.066×10^6	/ 0.9806×10^6	-

14.1.7 Moment of inertia

	lb-in ²	lb-ft ²	kg-m ²	kg-cm ²	kp-cm-s ²	oz-in ²
lb-in ²	-	/ 144	/ 3417.16	/ 0.341716	/ 335.109	* 16
lb-ft ²	* 144	-	* 0.04214	* 421.4	* 0.429711	* 2304
kg-m ²	* 3417.16	/ 0.04214	-	* 10×10^3	* 10.1972	* 54674
kg-cm ²	* 0.341716	/ 421.4	/ 10×10^3	-	/ 980.665	* 5.46
kp-cm-s ²	* 335.109	/ 0.429711	/ 10.1972	* 980.665	-	* 5361.74
oz-in ²	/ 16	/ 2304	/ 54674	/ 5.46	/ 5361.74	-

14.1.8 Temperature

	°F	°C	K
°F	-	(°F - 32) * 5/9	(°F - 32) * 5/9 + 273.15
°C	°C * 9/5 + 32	-	°C + 273.15
K	(K - 273.15) * 9/5 + 32	K - 273.15	-

14.1.9 Conductor cross section

AWG	1	2	3	4	5	6	7	8	9	10	11	12	13
mm ²	42.4	33.6	26.7	21.2	16.8	13.3	10.5	8.4	6.6	5.3	4.2	3.3	2.6

AWG	14	15	16	17	18	19	20	21	22	23	24	25	26
mm ²	2.1	1.7	1.3	1.0	0.82	0.65	0.52	0.41	0.33	0.26	0.20	0.16	0.13

14.2 Terms and Abbreviations

<i>Actual position</i>	Current position of moving components in the drive system.
<i>ARP</i>	Address Resolution Protocol , links the data link layer and the network layer in the OSI model.
<i>Big Endian format</i>	Method of storing data; the highest-value byte of a data word is at the first position (big end first).
<i>cid</i>	Command ID
<i>Client</i>	First transmitter, then recipient of fieldbus messages in the client-server relationship. Starts transmission with a transmission to the server; the reference point is the server object dictionary.
<i>Default value</i>	Factory setting.
<i>Degree of protection</i>	The degree of protection is a standardized specification for electrical equipment that describes the protection against the ingress of foreign objects and water (for example: IP 20).
<i>DHCP server</i>	The task of the DHCP server is to assign an IP configuration (IP address, subnet mask, gateway, etc.) to other network devices. The network devices do not need to know the IP address of the DHCP server to obtain the configuration.
<i>Direction of rotation</i>	Rotation of the motor shaft in a clockwise or counterclockwise direction of rotation. Clockwise rotation is when the motor shaft rotates clockwise as you look at the end of the protruding motor shaft.
<i>DOM</i>	The Date of manufacturing on the nameplate of the device is shown in the format DD.MM.YY, for example 31.12.06 (December 31, 2006).
<i>Drive system</i>	System consisting of controller, power stage and motor.
<i>EDS</i>	(Electronic Data Sheet) ; contains the specific properties of a product.
<i>EMC</i>	Electromagnetic compatibility
<i>Encoder</i>	Sensor for detection of the angular position of a rotating component. Installed in a motor, the encoder shows the angular position of the rotor.
<i>Error</i>	Discrepancy between a computed, observed or measured value or condition and the specified or theoretically correct value or condition.
<i>Error class</i>	Classification of errors into groups. The different error classes allow for specific responses to faults, for example by severity.
<i>Fatal error</i>	In the case of fatal error, the product is not longer able to control the motor, so that an immediate deactivation of the power stage is necessary.
<i>Fault</i>	Operating state of the drive caused as a result of a discrepancy between a detected (computed, measured or signaled) value or condition and the specified or theoretically correct value or condition.
<i>Fault reset</i>	A function used to restore the drive to an operational state after a detected error is cleared by removing the cause of the error so that the error is no longer active (transition from operating state "Fault" to state "Operation Enable").
<i>FMMU</i>	Fieldbus Memory Management Unit , converts logical addresses into physical addresses. This way, the FMMU can logically address a data range that comprises several slaves.

<i>FTP</i>	F ile T ransfer P rotocol
<i>Gateway</i>	The gateway is a separate network station. All IP packets whose target address is not in the same subnet are sent to the gateway. If there is no gateway on the network, it is recommended to enter the IP address of the device.
<i>HTTP</i>	H yper T ext T ransfer P rotocol. Client-Server TCP//IP protocol used to transmit HTML documents on the internet and in intranets.
<i>I²t monitoring</i>	Anticipatory temperature monitoring. The expected temperature rise of components is calculated in advance on the basis of the motor current. If a limit value is exceeded, the drive reduces the motor current.
<i>I/O</i>	Inputs/outputs
<i>Inc</i>	Increments
<i>Index pulse</i>	Signal of an encoder to reference the rotor position in the motor. The encoder returns one index pulse per revolution.
<i>Internal units</i>	Resolution of the power stage at which the motor can be positioned. Internal units are specified in increments.
<i>IP</i>	I nternet P rotocol (as opposed to Ethernet/IP where IP stands for Industrial Protocol)
<i>IP address</i>	The IP address consists of four bytes. The common notation is to separate the bytes by dots (example: 192.168.0.1). The first IP address of an IP network is the network address and must not be assigned to a device. The last address of an IP network is the broadcast address. It must not be assigned to a device.
<i>LED</i>	Light Emitting Diode
<i>Limit switch</i>	Switches that signal overtravel of the permissible range of travel.
<i>Little Endian format</i>	Method of storing data; the lowest-value byte of a data word is at the first position (little end first).
<i>LSB</i>	L east S ignificant B it in a telegram
<i>MAC address</i>	Node address (MAC=Media Access Control), a hardware address for unique identification of a device in the network. The MAC address is assigned to the data link layer of the OSI model.
<i>Mailbox</i>	The mailbox is used for asynchronous, non-realtime data transmission.
<i>Master</i>	Active bus device that controls the data traffic on the network.
<i>MSB</i>	M ost S ignificant B it in a telegram. Not in List
<i>MT</i>	M ode T oggle, toggling a bit from 0 -> 1 or 1 -> 0
<i>OSI model</i>	Describes and categorizes specific components in a communication system.
<i>Parameter</i>	Device data and values that can be set by the user.
<i>PDO</i>	P rocess D ata O bjects.
<i>PDU</i>	P rotocol D ata U nit
<i>PLC</i>	Programmable logic controller
<i>Power stage</i>	The power stage controls the motor. The power stage generates current for controlling the motor on the basis of the positioning signals from the controller.

<i>PELV</i>	Protective Extra Low Voltage, low voltage with isolation. For more information: IEC 60364-4-41
<i>Persistent</i>	Indicates whether the value of the parameter remains in the memory after the device is switched off.
<i>Quick Stop</i>	Function used to enable fast deceleration of the motor via a command or in the event of an error.
<i>RCD</i>	Residual Current Device
<i>rms</i>	Root Mean Square value of a voltage (V_{rms}) or a current (A_{rms})
<i>RO , RW</i>	Read Only = Parameter can only be read Read/Write = Parameter can be read and written
<i>RS485</i>	Fieldbus interface as per EIA-485 which enables serial data transmission with multiple devices.
<i>SCNM</i>	S lot C ommunication N etwork M anagement. SCNM is a polling mechanism
<i>SDO</i>	S ervice D ata O bjects.
<i>Scaling factor</i>	This factor is the ratio between an internal unit and a user-defined unit.
<i>Server</i>	First the transmitter, then the recipient of fieldbus messages in the client-server relationship; responds to the request of a client; the reference point is the server object dictionary
<i>Slave</i>	Passive bus device that receives control commands and provides data to the master.
<i>Slave address</i>	Communication between master and slave is only possible after the assignment of unique addresses.
<i>Subnet mask</i>	The subnet mask is used to distinguish between the network address and the network device address.
<i>Sync Manager</i>	The Sync Manager control access to the memory of the application. Each channel specifies a suitable range of this memory.
<i>TCP</i>	T ransport C ontrol P rotocol
<i>Toggle</i>	The value of a bit changes from 0 to 1 or vice versa, see MT, ModeToggle
<i>UDP</i>	U ser D atagram P rotocol, supports application-to-application data exchange between computers. UDP is based on the underlying IP protocol.
<i>User-defined unit</i>	Unit whose reference to motor rotation can be determined by the user via parameters.
<i>Warning</i>	If the term is used outside the context of safety instructions, a warning alerts to a potential problem that was detected by a monitoring function. A warning is not an error and does not cause a transition of the operating state.
<i>Watchdog</i>	Unit that monitors cyclic basic functions in the product. The power stage is disabled and the outputs are switched off in the event of errors.

15 Index

Numerics

- 24V signal interface
 - Cable specifications and terminal 71
 - Connecting 71

A

- Abbreviations 245
- Absolute positioning in Profile Positioning operating mode 132
- Accessories and spare parts 237
- Air humidity 25
- Ambient conditions 25
 - Air humidity operation 25
 - Operation 25
 - Relative air humidity operation 25
 - Transportation and storage 25

B

- Before you begin
 - Safety information 19
- Brake function 173
- Braking ramp, see deceleration ramp

C

- Cable specifications
 - Fieldbus interface CAN 68
 - Protected cable installation 49
- Cable specifications and terminal
 - 24V signal interface 71
 - Fieldbus interface RS485 70
 - Safety function STO 73
 - Supply voltage 66
- Cables, assembling 61
- Category 0 stop 48
- Category 1 stop 48
- Cause of stop, last 194
- Certifications 25
- Change
 - Operating mode 126
- Changing the operating state 123
- Checking direction of rotation 100
- Checking limit switches 97
- Commissioning 77
 - Checking direction of rotation 100
 - Checking limit switches 97
 - checking safety function STO 98
 - controller structure 104
 - Digital inputs and outputs 96
 - Holding brake, manual release 99
 - optimizing controller 104
 - optimizing speed controller 106
 - presets and optimization 110

- Setting basic parameters 93
- setting parameters for encoder 101
- steps 81
- Commissioning software 86, 237
 - Error indication 193
 - Online help 86
 - Setting reference signal 105
 - Step function 105
- Commissioning software Lexium CT 86
- Components and interfaces 12
- Connection monitoring 91
- Controller
 - optimizing 104
 - Values 105
- controller
 - structure 104
- Current
 - Position 135
 - Speed 137
- Current controller
 - Function 104

D

- Data frame 36
- Deceleration ramp, setting 163
- Declaration of conformity 17
- Definition
 - STO 48
- Determining control parameter values
 - Control parameter values for rigid mechanical systems 107
- Determining controller values
 - determining controller values with less rigid mechanics 107
- Device LEDs 193
- Diagnostics 191
- Digital inputs and outputs
 - Modify 96
- dimensional drawing, see dimensions
- Dimensions 28
- Direction reversal 179
- Disposal 239, 242
- Documentation and literature references 16

E

- Electrical installation 58
- EMC 54
- EPLAN Macros 16, 237
- Equipotential bonding conductors 47, 55
- Error class 199
- Error indication 191
 - Commissioning software 193
 - Fieldbus 194
- Error response 118
 - Meaning 199
- Example
 - Function codes FC 41

- Examples 189
- External power supply unit 45
- F**
- Fast position capture 170
- Fieldbus
 - Error indication 194
- Fieldbus interface CAN
 - Cable specifications 68
 - Function 68
- Fieldbus interface RS485
 - Cable specifications and terminal 70
- Fields, data frame 36
- Function
 - Fieldbus interface CAN 68
- Functional safety 23, 33
- Functions 152
 - Brake function 173
 - direction reversal 179
 - Fast position capture 170
 - Halt 168
 - monitoring functions 152
 - Quick Stop 166
 - restoring default values 181
 - scaling 160
 - standstill window 172
 - travel profile 163
- Functions of the commissioning software 86
- G**
- Glossary 243
- H**
- Halt 168
- Hazard categories 20
- Holding brake, manual release 99
- Homing 138
- Homing by position setting
 - Position setting 151
- Humidity 25
- I**
- I2t 155
- Installation
 - electrical 58
 - mechanical 56
- Installation, electrical
 - Assembling cables 61
 - Connecting 24V signal interface 71
 - Connecting supply voltage 65
- Intended use 19
- Interface signal
 - FAULT_RESET 166
- Interruption of the Ethernet connection 91

Introduction 11
IO scanning 42

J

Jerk limitation 164
Jog 127

L

Last cause of stop 194
LEDs
 Device 193
Lexium CT commissioning software 86
Limit switch
 Limit switch 154
 Moving the drive away from the switch 155
 Reference movement without index pulse 143
Limit values
 setting 93

M

Macros EPLAN 16, 237
Maintenance 239
manuals 16
Max. humidity operation 25
Mechanical installation 56
Mechanical system, design for control system 106
Modbus message 36
Monitoring
 Parameters 156
Monitoring functions 52, 152
Mounting position 28

N

Name plate 14

O

Operating mode
 Change 126
 Homing 138
 homing 138
 jog 127
 profile position 132
 profile velocity 136
 speed control 131
 Start 125
Operating modes 127
Operating states 117
Operation 113
Operation ambient temperature 25
Operation mode finished
 profile velocity 136
Optimizing presets 110
Overview 80

P

- Parameter
 - representation 207
- Parameters 207
- Position
 - Current 135
 - Target 134
- Position controller
 - Function 105
 - optimizing 111
- Position setting 151
- Positioning finished 133
- Positioning limits 153
- Prerequisites
 - For setting the operating mode 125
- product manuals 16
- Profile generator 163
- Profile position 132
- Profile velocity 136
- Protected cable installation 49

Q

- Qualification of personnel 19
- Quick Stop 166

R

- Ramp
 - shape 163
 - Steepness 163
- REF, see reference switch
- Reference movement with index pulse 146
- Reference movement without index pulse 143
- Reference signal
 - Setting 105
- Reference switch
 - Reference movement with index pulse 148
 - Reference movement without index pulse 144
- Reference variable filter 107
- Relative air humidity 25
- Relative positioning in Profile Position operating mode 132
- Request 36
- Response 36
- Restoring default values 181

S

- Safe Torque Off 48
 - Definition 48
- Safety disconnect moment 48
- Safety function 48
 - Application examples 51
 - Category 0 stop 48
 - Category 1 stop 48
 - Definition 48
 - Definitions 48

- Requirements 49
- Safety function STO
 - Cable specifications and terminal 73
- Scaling 160
- Service 239
- Service address 240
- Set speed 137
- Setting parameters for encoder 101
- Shielding 54
- Shipping 242
- Software limit switches 153
- Source
 - Commissioning software 86, 237
 - EPLAN Macros 16, 237
 - product manuals 16
- Speed control 131
- Speed controller
 - Function 104
 - setting 106
- Standstill window 172
- Start
 - Operating mode 125
- State diagram 117
- State transitions 118
- Status monitoring during operation 152
- Step function 105
- STO 48
 - Application examples 51
 - Definitions 48
 - Requirements 49
- Storage 242
- Supply voltage
 - Cable specifications and terminal 66
 - Connecting 65
- System requirements 86

T

- Target position 134
- Technical data 25
- Telegram 36
- Temperature 155
- Temperature during operation 25
- Terms 245
- Testing safety function STO 98
- Timeout monitoring
 - For I/O Scanning 91
 - For individual Modbus TCP channels 91
- Tracking error
 - monitoring function 156
- Travel profile 163
- Trigger positioning 132
- Troubleshooting 191, 196
 - Errors by bit class 197
- Type code 15

U

Unit overview 11
Units and conversion tables 243
User Association 16

