

Modular Connector System with High Power, Signal, Fibre-Optic, Coaxial Contacts and Pneumatic Valves



Modular Connector System with High Power, Signal, Fibre-Optic, Coaxial Contacts and Pneumatic Valves



Applications

- Measuring and testing
- Medical
- Industrial
- Military and security
- Energy
- Automotive

Features

- High mating cycles ($\geq 100,000$)
- High number of contact points
- Each springwire is independent of adjacent springwires
- High reliability
- Modularly attachable
- Robust

All shown connectors are according to DIN EN 61984:2009 connectors without breaking capacity (COC).

All dimensions in mm.
Most of the pictures are illustrations.
All data and specifications subject to change without notice.

UL-File E110586
Tested according to MIL: see page [121](#).

Issue 2013-04

Table of Contents (Part I)

Chapter		From page	
1	Product description	<u>5</u>	
2	Modules	<u>13</u>	
	Overview modules	<u>14</u>	
	Modules technical information:		
	– Standard modules	<u>20</u>	
	– Power / voltage modules	<u>36</u>	
	– Coaxial modules	<u>48</u>	
	– Modules for gases and liquids	<u>58</u>	
	– Plastic and fibre-optic modules	<u>66</u>	
	– Multi-positions modules with shielding	<u>72</u>	
	– Accessories for modules	<u>80</u>	
3	ODU-MAC in the aluminium frame	<u>83</u>	
	Ordering system and information on the aluminium frames	<u>84</u>	
	ODU-MAC S	<u>86</u>	
	ODU-MAC L	<u>87</u>	
	ODU-MAC M	<u>88</u>	
	ODU-MAC P	<u>89</u>	
	ODU-MAC transverse frame	<u>90</u>	
4	ODU-MAC in the DIN housing	<u>91</u>	
	Frames for DIN housings	<u>92</u>	
	Coding forms	<u>93</u>	
	Bulkhead mounted housing	<u>94</u>	
	Cable hood	<u>95</u>	
	Surface mounted housing	<u>96</u>	
	DIN housing with spindle locking	<u>97</u>	
	Cable to cable hood	<u>98</u>	
	Spindle locking	<u>99</u>	
	EMC housing / corrosion protection housing	<u>100</u>	
	Cable clamp, protective cover	<u>101</u>	
	Blind grommet, adapter ring	<u>102</u>	
5	Application specific solutions	<u>103</u>	
	Application specific solutions based on the ODU-MAC	<u>104</u>	
	ODU-MAC quick-change head	<u>106</u>	
6	Tools, crimp information, processing instructions	<u>107</u>	
	Crimp information	<u>108</u>	
	Crimping tools	<u>109</u>	
	Crimp termination	<u>112</u>	
	Contact removal	<u>114</u>	
	Coaxial contact assembly	<u>115</u>	
	Maintenance kit	<u>116</u>	

Table of Contents (Part II)

Chapter		From page	
7	Technical information	<u>117</u>	
	Explanations and information in compliance with VDE	<u>118</u>	
	Explanations of voltage information according to MIL	<u>121</u>	
	Current carrying capacity	<u>122</u>	
	International protection (IP) classes	<u>127</u>	
	AWG – cross section conversions	<u>128</u>	
	Technical terms / definitions / information	<u>129</u>	
8	Company information / order information	<u>131</u>	
	Company information:		
	– Quality management	<u>132</u>	
	– Your partner in many application areas	<u>133</u>	
	– The complete ODU product range	<u>134</u>	
	– Everything from one source	<u>135</u>	
	– Application specific connectors	<u>136</u>	
	Order information:		
	– Module overview	<u>138</u>	
	– Frame sizes	<u>139</u>	

Product Description

ODU-MAC



Product Description

The ODU-MAC is a modular rectangular connector which consists of a stable aluminium frame, various modules and, where required, a DIN housing. The various modules can be strung together in any way, allowing you to put together your individual connector. The modular construction makes it possible to combine many individual connectors in one ODU-MAC.

The ODU-MAC has been designed particularly for use as a service and interface connector. This connector is used everywhere that demands a high number of mating cycles and the highest quality standards in the most compact space.



Housing



Modules

Pin frame



Socket frame

Modules



Housing

ODU-MAC Aluminium Frame for Automated Mating



The Alu-S frame has two end pieces and two rails with guiding and mounting hardware. On the ODU-MAC S frame, the socket piece (receptacle) generally has a fixed mounting while the pin piece (plug) typically has a floating mounting. This system can accept between 3 and 60 units. For example, if a 10 position module is used, up to 600 contacts can be assembled.

Also available are versions for limited available space (Alu-M), more stringent requirements for a floating mounting (Alu-L) and increased mechanical loads (Alu-P). You can find information on these frames starting on page [83](#).

ODU-MAC Solid Frames for DIN Housing (Manual Mating)



ODU-MAC in DIN housing with lever locking system

For use in the standard DIN-EN 175301-801:2006 housing with a lever; four corresponding frames in four sizes are available. Size 1 can hold a total of ten modules and size 4 can hold 34 modules (units) with a module width of 2.54 mm, which means that size 4 can accommodate a total of 34 times a 10 position modules or 340 contacts.



ODU-MAC in DIN housing with locking spindle

As an alternative to the locking lever, the DIN housings can be equipped with an easy-to-use precision locking spindle. This spindle allows simple closing and opening of the housing with a single twist. Use of the precision spindle locking has proven very successful, particularly for a large number of mating cycles and limited space.

The precision mechanical system has been designed for up to 30,000 locking actions, depending on the application.

Further information on the use in the housing is given starting on page [91](#).

The Contact Principle

ODU contacts fulfil the highest quality standards and ensure reliable connections. ODU uses different proven contact technologies. Turned contacts are fundamentally classified as either:

- Lamella contacts or
- Springwire contacts.

These contacts differ only in the socket piece; the pins are the same and are always solid.

ODU SPRINGTAC® (contacts with springwire technology)

The springwire contact is the inspired invention of Otto Dunkel. It offers the highest number of contact surfaces. The spring wires are mounted individually and joined optimally to a turned carrier. The individual springwires contact and cushion independently of one another.

Advantages

- More than 100,000 mating cycles
- High current carrying capacity (up to 2,000 A)
- Low contact resistances
- Large number of independently cushioning contact springs
- Low insertion forces
- Extremely secure contacting
- High resistance to vibrations and impacts
- Long life span due to premium materials and surfaces
- Many styles and termination types are on hand or feasible.

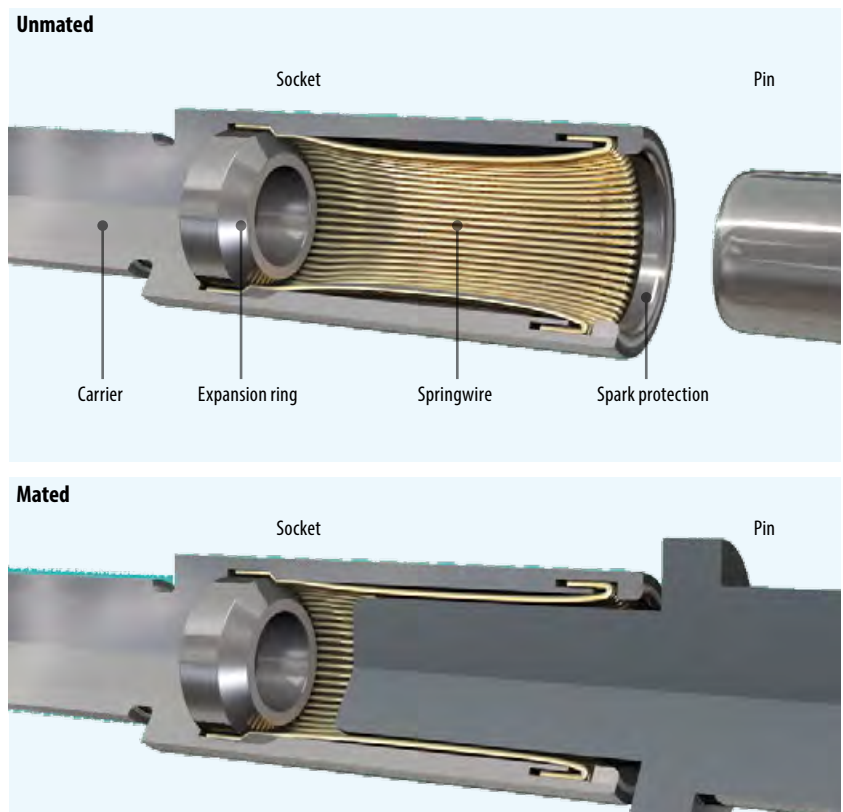

ODU LAMTAC® (contacts with lamella technology)

The lamella contact offers fewer contact surfaces than the ODU SPRINGTAC® contact. One or more stamped lamellas are mounted in a turned carrier. Usually 10,000 mating cycles are possible.

Advantages

- More than 10,000 mating cycles
- High current carrying capacity
- Low contact resistances
- Low insertion forces
- Secure contacting
- High resistance to vibrations and impacts
- Long life due to premium materials and surfaces
- Many styles and termination types are on hand or feasible
- Economical alternative to springwire contacts.

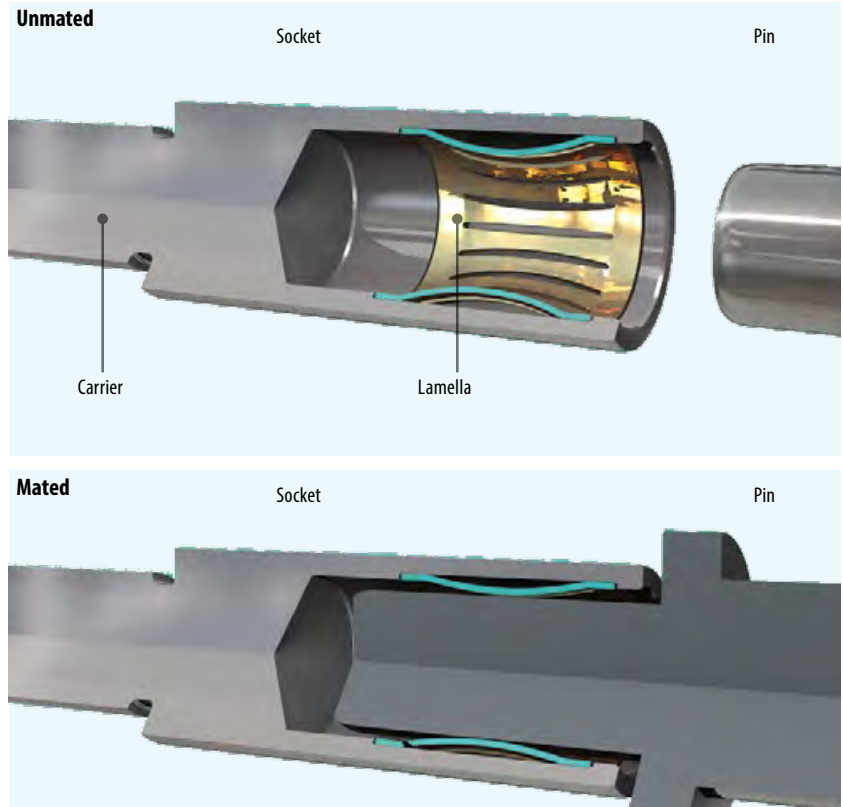

Insulators

ODU currently manufactures 30 different versions of insulators. The figure here shows a few examples. The insulators are made of glass-filled thermoplastic materials (listed in accordance with UL-94). Special versions made of liquid crystal polymer (LCP) are available in several module types for special requirements (high temperature, radioactivity). The insulator width is 2.54 mm or a multiple of this.

The contacts are snapped into place in the insulator. In most cases, they can be removed again in a few seconds with a tool. The insulators are held in the aluminium rails or DIN frame with powerful guide profiles.

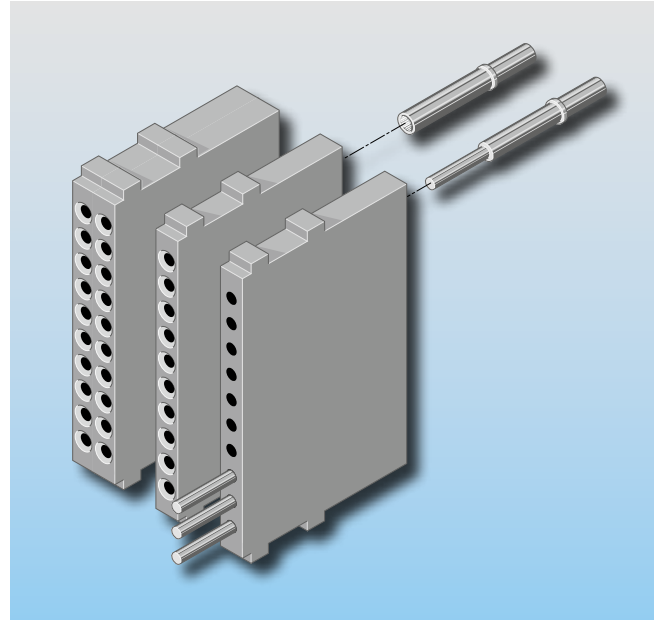

Contact Attachment with Clip Principle (Standard)

This figure shows the attachment of a contact in the insulator. The contact is slid into the insulator from the termination side (from the back) and is latched when the metal clip (barbed hook) snaps behind a collar. The contacts can be removed again easily with a removal tool.

This mounting method has the advantage of crimp termination technology, which permanently mounted, pressed contacts do not offer. This type of mounting allows the voltage levels to be raised reliably when contact positions are left free. Contact assembly is possible independently of the insulator.

Further mounts are likewise available for different contact types, such as media feed-throughs.

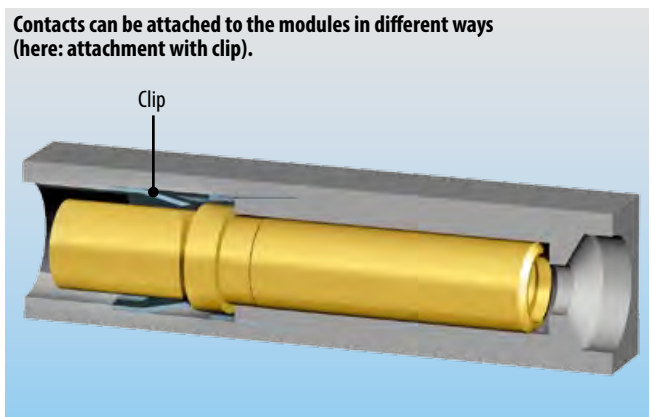

Modules



Modules



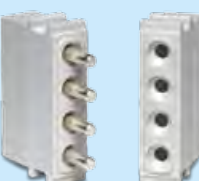

Overview of All Modules for ODU-MAC

Modules	Description	Units/width	Electrical properties	Page
	10 positions for turned contacts contact \varnothing : 0.76 mm	1 unit (2.54 mm)	Operating voltage: ¹⁾ 250V Rated impulse voltage: ¹⁾ 1,500V Rated current: ²⁾ 7.5 A at 0.38 mm ² Pollution degree: ¹⁾ 2 Mating cycles: min. 100,000	20
	10 positions for stamped contacts	1 unit (2.54 mm)	Operating voltage: ¹⁾ 32V Rated impulse voltage: ¹⁾ 1,500V Rated current: ²⁾ 4.5 A at 0.38 mm ² Pollution degree: ¹⁾ 2 Mating cycles: min. 5,000	22
	6 positions for turned contacts contact \varnothing : 1.02 mm	2 units (5.08 mm)	Operating voltage: ¹⁾ 400V Rated impulse voltage: ¹⁾ 3,000V Rated current: ²⁾ 9 A at 0.5 mm ² Pollution degree: ¹⁾ 2 Mating cycles: min. 100,000	24
	14 positions for turned contacts contact \varnothing : 1.02 mm	3 units (7.62 mm)	Operating voltage: ¹⁾ 320V Rated impulse voltage: ¹⁾ 2,500V Rated current: ²⁾ 9 A at 0.5 mm ² Pollution degree: ¹⁾ 2 Mating cycles: min. 100,000	26
	5 positions for turned contacts contact \varnothing : 1.5 mm	2 units (5.08 mm)	Operating voltage: ¹⁾ 500V Rated impulse voltage: ¹⁾ 2,500V Rated current: ²⁾ 18 A at 1.5 mm ² Pollution degree: ¹⁾ 2 Mating cycles: min. 100,000	28
	4 positions for turned contacts contact \varnothing : 2.41 mm	3 units (7.62 mm)	Operating voltage: ¹⁾ 500V Rated impulse voltage: ¹⁾ 3,000V Rated current: ²⁾ 28 A at AWG 12 Pollution degree: ¹⁾ 2 Mating cycles: min. 100,000	30



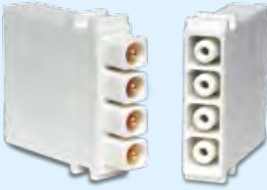
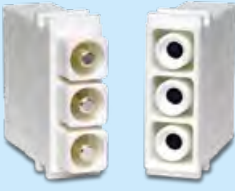



¹⁾ According to DIN EN 60664.1: 2007 (VDE 0110 part 1).

²⁾ Determined to DIN 60512-5-1: 2002 with 45 K increase of temperature.

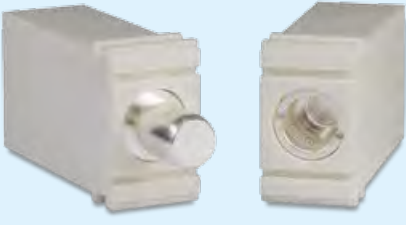
Modules	Description	Units/width	Electrical properties	Page
	3 positions for turned contacts contact \varnothing : 3.0 mm	3 units (7.62 mm)	Operating voltage: ¹⁾ 500 V Rated impulse voltage: ¹⁾ 3,000 V Rated current: ²⁾ 39 A at 6 mm ² Pollution degree: ¹⁾ 2 Mating cycles: min. 100,000	32
	2 positions for turned contacts contact \varnothing : 5.0 mm	5 units (12.7 mm)	Operating voltage: ¹⁾ 1,000 V Rated impulse voltage: ¹⁾ 4,000 V Rated current: ²⁾ 80 A at 16 mm ² Pollution degree: ¹⁾ 2 Mating cycles: min. 100,000	34
	4 positions high voltage module with turned contacts contact \varnothing : 1.5 mm	3 units (7.62 mm)	Operating voltage: ¹⁾ 2,500 V Rated impulse voltage: ¹⁾ 10,000 V Rated current: ²⁾ 18 A at 1.5 mm ² Pollution degree: ¹⁾ 2 Mating cycles: min. 100,000	36
	3 positions power module with turned contacts contact \varnothing : 3.0 mm	4 units (10.16 mm)	Operating voltage: ¹⁾ 2,500 V Rated impulse voltage: ¹⁾ 10,000 V Rated current: ²⁾ 39 A at 6 mm ² Pollution degree: ¹⁾ 2 Mating cycles: min. 100,000	38
	2 positions for power contacts ODU LAMTAC® (contacts with lamella technology) with turned contacts contact \varnothing : 8.0 mm	6 units (15.24 mm)	Operating voltage: ¹⁾ 500 V Rated impulse voltage: ¹⁾ 3,000 V Rated current: ²⁾ 105 A at 25 mm ² Pollution degree: ¹⁾ 2 Mating cycles: min. 10,000	40
	2 positions for power contacts ODU SPRINGTAC® (contacts with springwire technology) with turned contacts contact \varnothing : 8.0 mm	6 units (15.24 mm)	Operating voltage: ¹⁾ 500 V Rated impulse voltage: ¹⁾ 3,000 V Rated current: ²⁾ 100 A at 25 mm ² Pollution degree: ¹⁾ 2 Mating cycles: min. 100,000	42

¹⁾ According to DIN EN 60664.1: 2007 (VDE 0110 part 1).

²⁾ Determined to DIN 60512-5-1: 2002 with 45 K increase of temperature.

Modules	Description	Units/width	Electrical properties	Page
	1 position for power contacts ODU LAMTAC® (contacts with lamella technology) lamella \varnothing 10 mm or lamella \varnothing 12 mm	7 units (17.78 mm) at both versions	Version: 10 mm 12 mm Operating voltage: ¹⁾ 250 V 200 V Rated impulse voltage: ¹⁾ 4,000 V 3,000 V Rated current: ²⁾ 120 A at 35 mm ² 145 A at 50 mm ² Pollution degree: ¹⁾ 2 Mating cycles: min. 10,000 min. 10,000	44
	1 position for high voltage contacts	8 units (20.32 mm)	Operating voltage: ¹⁾ 6,300 V Rated impulse voltage: ¹⁾ 20,000 V Pollution degree: ¹⁾ 2 Mating cycles: min. 10,000	46
	4 positions for 50 Ω coaxial contacts non-magnetic	3 units (7.62 mm)	Frequency range: 0 – 1.2 GHz Mating cycles: min. 60,000	48
	2 positions for 50 Ω coaxial contacts	5 units (12.7 mm)	Frequency range: 0 – 2.2 GHz Mating cycles: min. 100,000	50
	2 positions for 50 Ω coaxial contacts SMA termination	5 units (12.7 mm)	Frequency range: 0 – 9.0 GHz Mating cycles: min. 100,000	52
	2 positions for 50 Ω coaxial contacts high voltage non-magnetic	5 units (12.7 mm)	Frequency range: 0 – 0.25 GHz Mating cycles: min. 100,000	54







¹ According to DIN EN 60664.1: 2007 (VDE 0110 part 1).

² Determined to DIN 60512-5-1: 2002 with 45 K increase of temperature.

Modules	Description	Units/width	Electrical properties		Page
	2 positions for 75 Ω coaxial contacts	5 units (12.7 mm)	Frequency range:	0 – 2 GHz	56
			Mating cycles:	min. 100,000	
	Module 2 positions for compressed air valves	5 units (12.7 mm)	Tube diameter:	max. 4 mm	58
			Mating cycles:	min. 5,000	
	Module 1 position for compressed air valve	8 units (20.32 mm)	Tube diameter:	max. 6 mm	60
			Mating cycles:	min. 5,000	
	Module 2 positions for compressed air valves	16 units (40.64 mm)	Tube diameter:	max. 6 mm	60
			Mating cycles:	min. 5,000	
	Module for fluid coupling plug	5 units (12.7 mm)	Mating cycles:	min. 15,000	62
	2 positions for fibre-optic contacts for plastic fibre	5 units (12.7 mm)	Insertion loss typical:	1.5 dB at 670 nm	66
			Mating cycles:	min. 100,000	

¹ According to DIN EN 60664.1: 2007 (VDE 0110 part 1).

² Determined to DIN 60512-5-1: 2002 with 45 K increase of temperature.

Modules	Description	Units/width	Electrical properties	Page
	5 positions for fibre-optic contacts for plastic fibre	2 units (5.08 mm)	Insertion loss typical: 1.5 dB at 670 nm Mating cycles: min. 40,000	68
	3 positions for fibre-optic contacts for fibre-glass	4 units (10.16 mm)	Insertion loss typical: 1.0 dB at 670 nm Mating cycles: min. 100,000	70
	2 to 10 positions, shielded implementation insert size 0	5 units (12.7 mm)	Mating cycles: min. 5,000	72
	2 to 14 positions, shielded implementation insert size 1	6 units (15.24 mm)	Mating cycles: min. 5,000 With springwire: min. 60,000	74
	4 to 8 positions, shielded implementation insert size 2	7 units (17.78 mm)	Mating cycles: min. 5,000 With springwire: min. 60,000	76
	10 to 30 positions, shielded implementation insert size 3	8 units (20.32 mm)	Mating cycles: min. 5,000	78

¹ According to DIN EN 60664.1: 2007 (VDE 0110 part 1).

² Determined to DIN 60512-5-1: 2002 with 45 K increase of temperature.

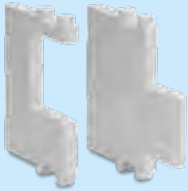
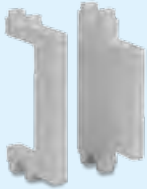
Modules	Description	Units/width	Electrical properties	Page
	Empty modules	1 unit (2.54 mm) 3 units (7.62 mm) 5 units (12.7 mm)		80
	Coding modules	1 unit (2.54 mm)		81
	Pin protection modules	1 unit (2.54 mm)		82

¹ According to DIN EN 60664.1: 2007 (VDE 0110 part 1).

² Determined to DIN 60512-5-1: 2002 with 45 K increase of temperature.

You can find further information on the modules on the following pages.

Module 10 Positions for turned contacts

Technical data

Voltage information ¹⁾

Operating voltage	250V	32V
Rated impulse voltage	1,500V	1,500V
Pollution degree	2	3

Voltage information acc. to MIL ²⁾

Operating voltage	500V
Test voltage	1,500V

Mechanical data

Total mating force (average)	13.5 N/module
Total demating force (average)	9.8 N/module
Contact diameter	0.76 mm
Operating temperature	-40°C to +125°C acc. UL 1977, second edition, max. 75°C
Mating cycles	min. 100,000

Materials

Insulator	Thermoplast, polyester fibre-glass reinforced acc. UL-94
Contact body	Cu alloy
Contact spring	Cu Be
Contact finish	0.75 µm Au over 1.25 µm Ni

Technical details

- The current load information is valid for single contacts or fully equipped modules, accordingly. For use in connector systems, the load should be reduced according to VDE 0298.
- Contacts and insulators up to 250°C upon request.
- Crimp information: see page [108](#).

¹ Acc. DIN EN 60664.1 : 2007 (VDE 0110 Teil 1). See page [118](#)

² See from page [121](#)

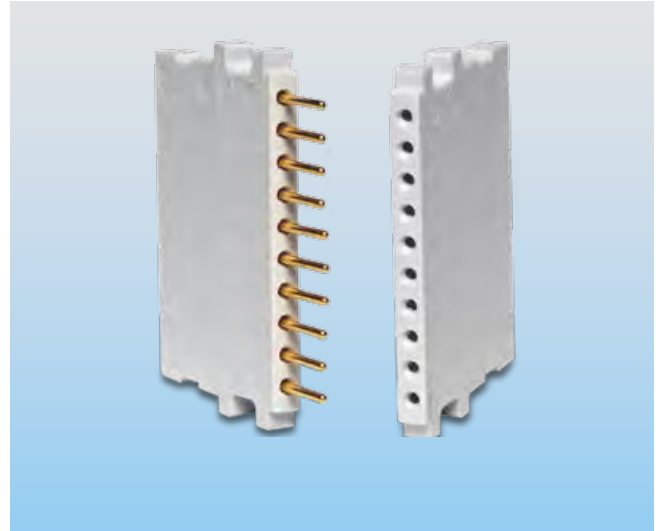

Removal tool I (angled)

Removal of already assembled contacts (including cable).
Part number 087.170.361.000.000



Removal tool II

Removal of contacts that have not been assembled yet
(without cable – may have to be cut off).
Part number 087.611.001.001.000

Module 10 positions for turned contacts

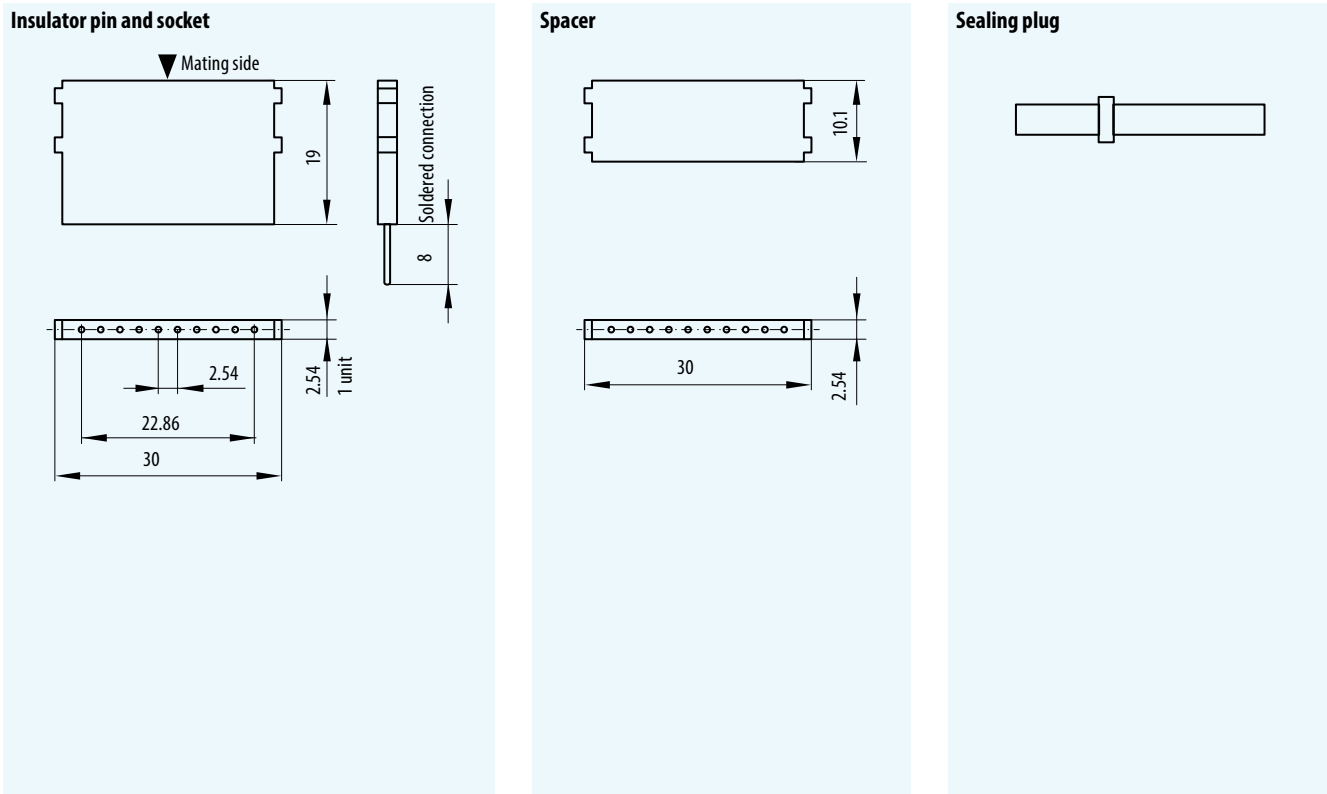

Modules

	Part number	Conductor cross-section mm ²	Termination AWG / mm	Nominal current ²⁾		Contact resistance average (mΩ)
				Single contact A	Fully equipped module A	
Insulator	611.122.110.923.000					
Spacer	611.122.111.923.000					
Pin contact short ¹⁾	180.361.000.307.000					
Pin contact long ¹⁾	180.381.000.307.000	0.38	22	7.5	6.0	3.8
Socket contact ¹⁾	170.361.700.207.000					
Pin contact short ¹⁾	180.540.000.307.000					
Pin contact long ¹⁾	180.570.000.307.000	0.08 / 0.25	24 / 28	6.0	5.0	3.8
Socket contact ¹⁾	170.540.700.207.000					
Pin contact short ¹⁾	180.850.000.307.000					
Pin contact long ¹⁾	180.851.000.307.000		Print termination ∅ 0.76 mm	7.5	6.0	3.8
Socket contact ¹⁾	170.850.700.207.000					
Sealing plug	021.341.123.923.000					

¹ Non-magnetic version on request.

² Determined to DIN 60512-5-1:2002 with 45 K increase of temperature.

Module 10 Positions for stamped contacts

Technical data

Voltage information ¹⁾

Operating voltage	32V	10V
Rated impulse voltage	1,500V	1,500V
Pollution degree	2	3

Voltage information acc. to MIL ²⁾

Operating voltage	450V
Test voltage	1,350V

Mechanical data

Total mating force (average)	5.0N/module
Total demating force (average)	4.8N/module
Contact diameter	0.7 mm
Operating temperature	-40°C to +125°C
Mating cycles	min. 5,000

Materials

Insulator	Thermoplast, polyester fibre-glass reinforced acc. UL-94
Contact	CuSn6
Contact finish	
- at termination area	3 µm Sn
- at contact area	0.75µm Au



Technical details

- The current load information is valid for single contacts or fully equipped modules, accordingly. For use in connector systems, the load should be reduced according to VDE 0298.
- The 10 position modules with turned contacts are not compatible with those are stamped.
- Crimp information: see page [108](#)
- Contacts cannot be removed.

¹ Acc. DIN EN 60664.1 : 2007 (VDE 0110 part 1). See page [118](#)

² See from page [121](#)

Module 10 positions for stamped contacts

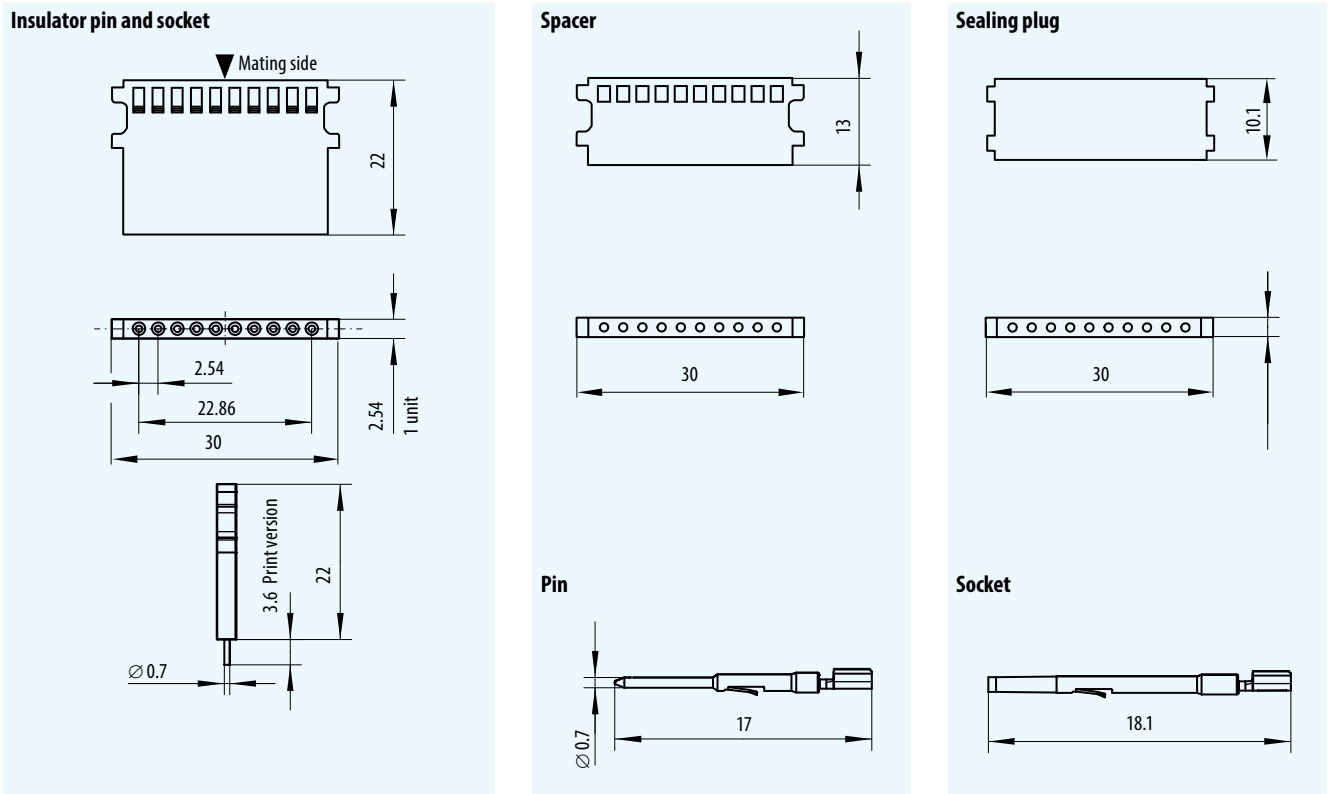

Modules

	Part number	Conductor cross-section mm ²	Termination AWG	Nominal current ¹⁾		Contact resistance average (mΩ)
				Single contact A	Fully equipped module A	
Insulator socket (crimp)	610.158.110.923.000					
Insulator pin (crimp)	611.158.110.923.000					
Insulator socket (with print)	610.158.010.923.000					
Spacer	611.122.111.923.000					
Pin contact	186.080.103.535.1..*)	0.15 / 0.08	26 / 28	3.5	2.5	3.8
Socket contact	176.082.103.535.1..*)					
Pin contact	186.080.103.535.2..*)	0.38 / 0.25	22 / 24	4.5	3.5	3.8
Socket contact	176.082.103.535.2..*)					

¹⁾ Determined to DIN 60512-5-1:2002 with 45 K increase of temperature.

*** Packaging for crimp version (per reel)**

Piece number	500	900	5,000	10,000	20,000
Code number	.51	.52	.54	.55	.50

Module 6 Positions

Technical data

Voltage information ¹⁾

Operating voltage	400V	160V
Rated impulse voltage	3,000V	3,000V
Pollution degree	2	3

Voltage information acc. to MIL ²⁾

Operating voltage	850V
Test voltage	2,550V

Mechanical data

Total mating force (average)	8.1 N/module
Total demating force (average)	5.9 N/module
Contact diameter	1.02 mm
Operating temperature	-40° C to +125° C
Mating cycles	min. 100,000

Materials

Insulator	Thermoplast, polyester fibre-glass reinforced acc. UL-94
Contact body	Cu alloy
Contact spring	Cu Be
Contact finish	0.75 µm Au over 1.25 µm Ni

Technical details

- The current load information is valid for single contacts or fully equipped modules, accordingly. For use in connector systems, the load should be reduced according to VDE 0298.
- Contacts and insulators up to 250° C on request.
- Crimp information: see page [108](#).

¹ Acc. DIN EN 60664.1 : 2007 (VDE 0110 part 1). See page [118](#)

² See from page [121](#)



Removal tool I (angled)

Removal of already assembled contacts (including cable).
Part number 087.170.362.000.000



Removal tool II

Removal of contacts that have not been assembled yet (without cable – may have to be cut off).
Part number 087.611.001.001.000

Module 6 positions

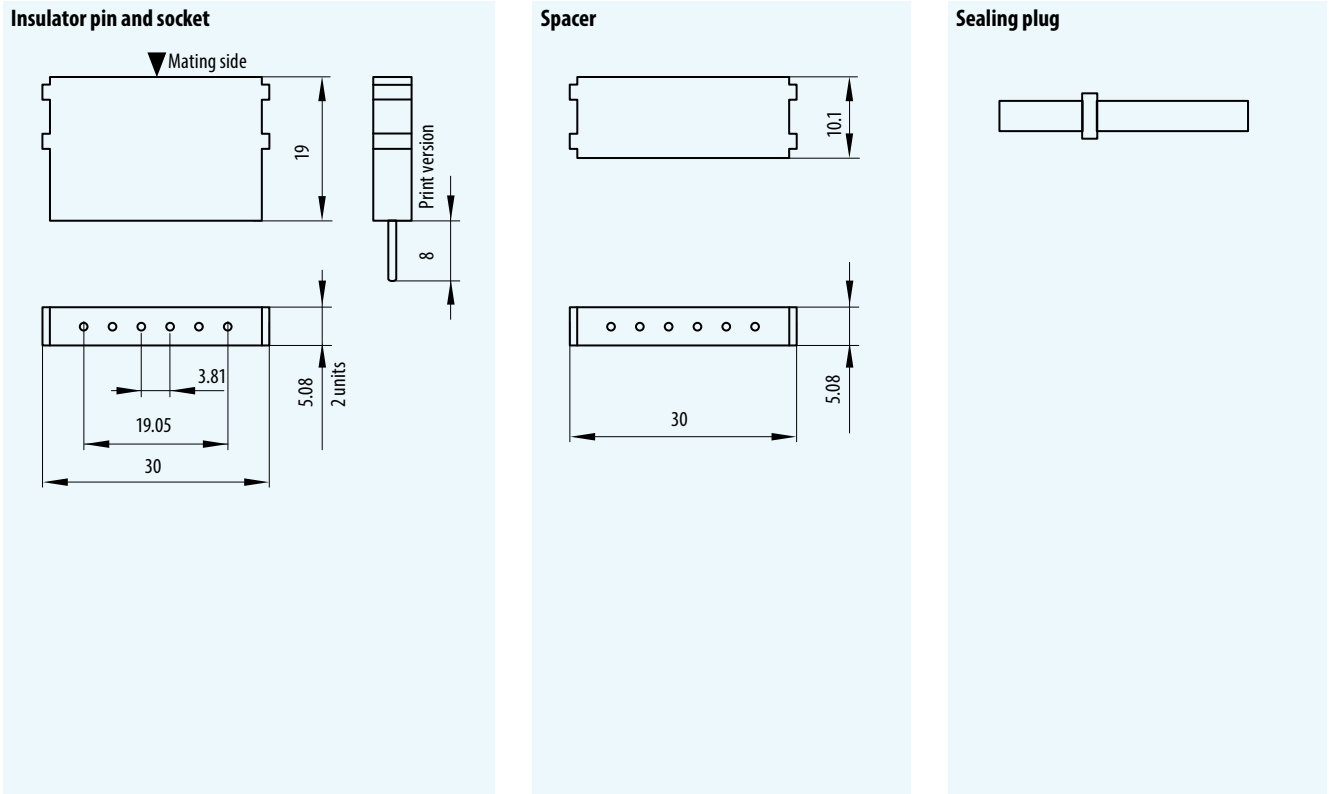

Modules

	Part number	Conductor cross-section mm ²	Termination AWG / mm	Nominal current ²⁾		Contact resistance average mΩ
				Single contact A	Fully equipped module A	
Insulator	611.123.106.923.000					
Spacer	611.123.111.923.000					
Pin contact short ¹⁾	180.362.000.307.000					
Pin contact long ¹⁾	180.382.000.307.000	0.50 / 0.38	20 / 22	9.0	8.0	2.1
Socket contact ¹⁾	170.362.700.207.000					
Pin contact short ¹⁾	180.544.000.307.000					
Pin contact long ¹⁾	180.574.000.307.000	0.25 / 0.08	24 / 28	6.0	6.0	2.1
Socket contact ¹⁾	170.544.700.207.000					
Pin contact short ¹⁾	180.818.000.307.000					
Pin contact long ¹⁾	180.819.000.307.000		Print termination ∅ 0.76 mm	9.0	8.0	2.1
Socket contact ¹⁾	170.818.700.207.000					
Sealing plug	021.341.124.923.000					

¹⁾ Non-magnetic version on request.

²⁾ Determined to DIN 60512-5-1:2002 with 45 K increase of temperature.

Module 14 Positions

Technical data

Voltage information ¹⁾

Operating voltage	320V	100V
Rated impulse voltage	2,500V	2,500V
Pollution degree	2	3

Voltage information acc. to MIL ²⁾

Operating voltage	950V
Test voltage	2,850V

Mechanical data

Total mating force (average)	18.9 N/module
Total demating force (average)	13.7 N/module
Contact diameter	1.02 mm
Operating temperature	-40° C to +125° C
Mating cycles	min. 100,000

Materials

Insulator	Thermoplast, polyester fibre-glass reinforced acc. UL-94
Contact body	Cu alloy
Contact spring	Cu Be
Contact finish	0.75 µm Au over 1.25 µm Ni

Technical details

- The current load information is valid for single contacts or fully equipped modules, accordingly. For use in connector systems, the load should be reduced according to VDE 0298.
- Contacts and insulators up to 250° C on request.
- Crimp information: see page [108](#).

¹ Acc. DIN EN 60664.1 : 2007 (VDE 0110 part 1). See page [118](#)

² See from page [121](#)

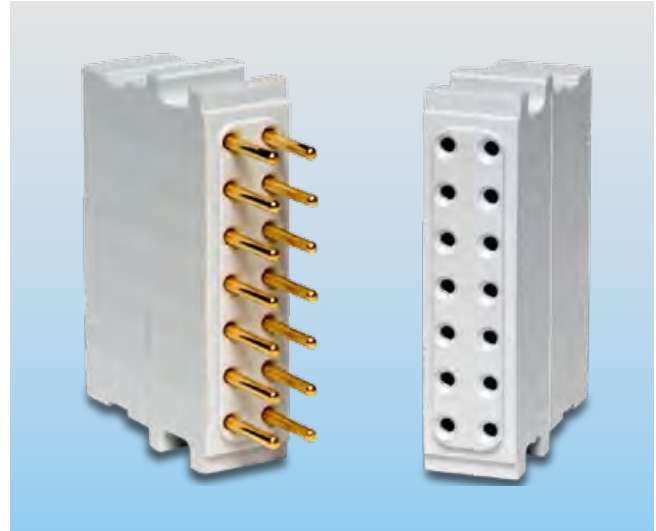

Removal tool I (angled)

Removal of already assembled contacts (including cable).
Part number 087.170.362.000.000



Removal tool II

Removal of contacts that have not been assembled yet (without cable – may have to be cut off).
Part number 087.611.001.001.000

Module 14 positions

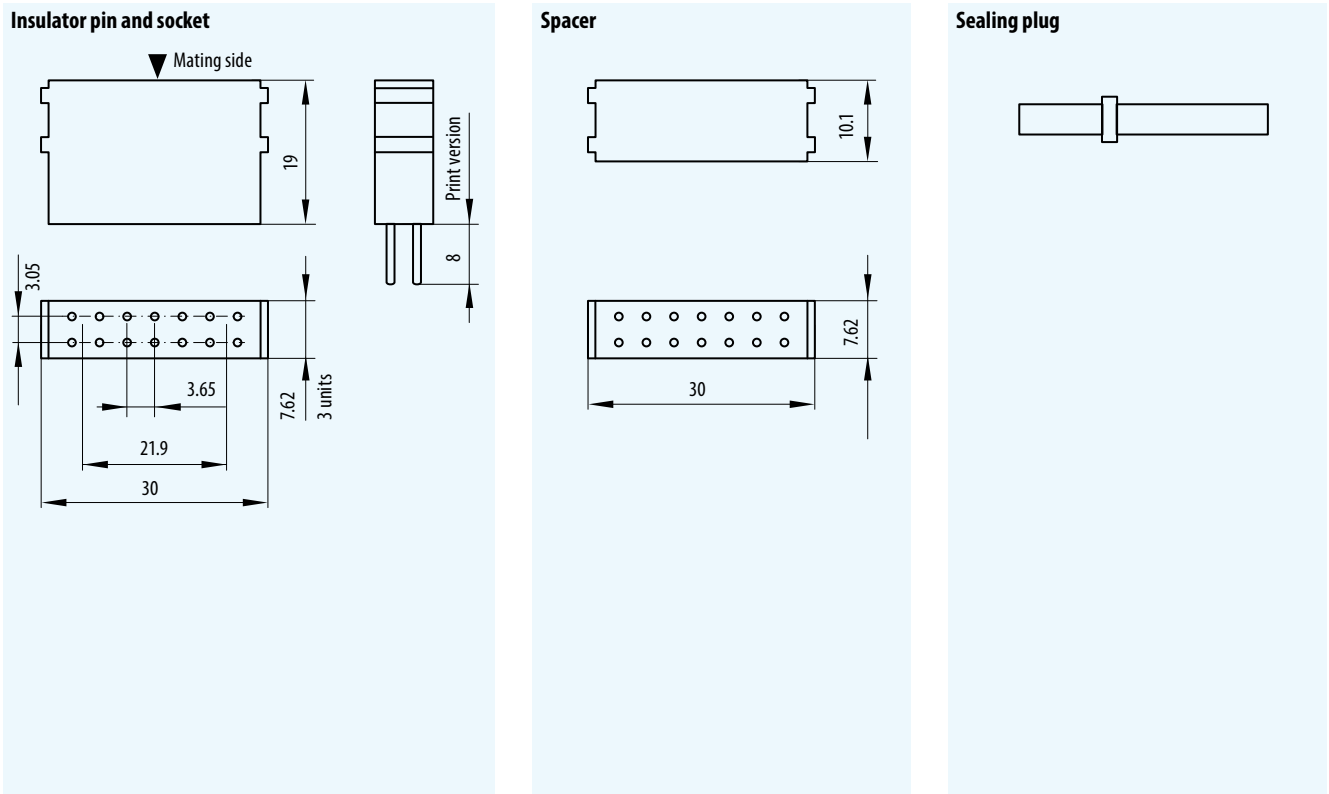

Modules

	Part number	Conductor cross-section mm ²	Termination AWG/mm	Nominal current ²⁾		Contact resistance average mΩ
				Single contact A	Fully equipped module A	
Insulator	611.130.114.923.000					
Spacer	611.130.111.923.000					
Pin contact short ¹⁾	180.362.000.307.000					
Pin contact long ¹⁾	180.382.000.307.000	0.50/0.38	20/22	9.0	7.0	2.1
Socket contact ¹⁾	170.362.700.207.000					
Pin contact short ¹⁾	180.544.000.307.000					
Pin contact long ¹⁾	180.574.000.307.000	0.25/0.08	24/28	6.0	5.0	2.1
Socket contact ¹⁾	170.544.700.207.000					
Pin contact short ¹⁾	180.818.000.307.000					
Pin contact long ¹⁾	180.819.000.307.000		Print termination ∅ 1.02 mm	9.0	7.0	2.1
Socket contact ¹⁾	170.818.700.207.000					
Sealing plug	021.341.124.923.000					

¹⁾ Non-magnetic version on request.

²⁾ Determined to DIN 60512-5-1:2002 with 45 K increase of temperature.

Module 5 Positions

Technical data

Voltage information ¹⁾

Operating voltage	500V	200V
Rated impulse voltage	2,500V	2,500V
Pollution degree	2	3

Voltage information acc. to MIL ²⁾

Operating voltage	750V
Test voltage	2,250V

Mechanical data

Total mating force (average)	22.5 N/module
Total demating force (average)	15.0 N/module
Contact diameter	1.5 mm
Operating temperature	-40° C to +125° C
Mating cycles	min. 100,000

Materials

Insulator	Thermoplast, polyester fibre-glass reinforced acc. UL-94
Contact body	Cu alloy
Contact spring	Cu Sn
Contact finish	
– Contact body	0.75 µm Au over 1.25 µm Ni
– Contact spring	3 µm Ag

Technical details

- The current load information is valid for single contacts or fully equipped modules, accordingly. For use in connector systems, the load should be reduced according to VDE 0298.
- Contacts and insulators up to 250° C on request.
- Crimp information: see page [108](#).

¹ Acc. DIN EN 60664.1 : 2007 (VDE 0110 part 1). See page [118](#)

² See from page [121](#)



Removal tool I (straight)

Removal of already assembled contacts (including cable).
Part number 087.170.138.000.000



Removal tool I (angled)

Removal of already assembled contacts (including cable).
Part number 087.170.363.000.000



Removal tool II

Removal of contacts that have not been assembled yet (without cable – may have to be cut off).
Part number 087.611.001.001.000

Module 5 positions

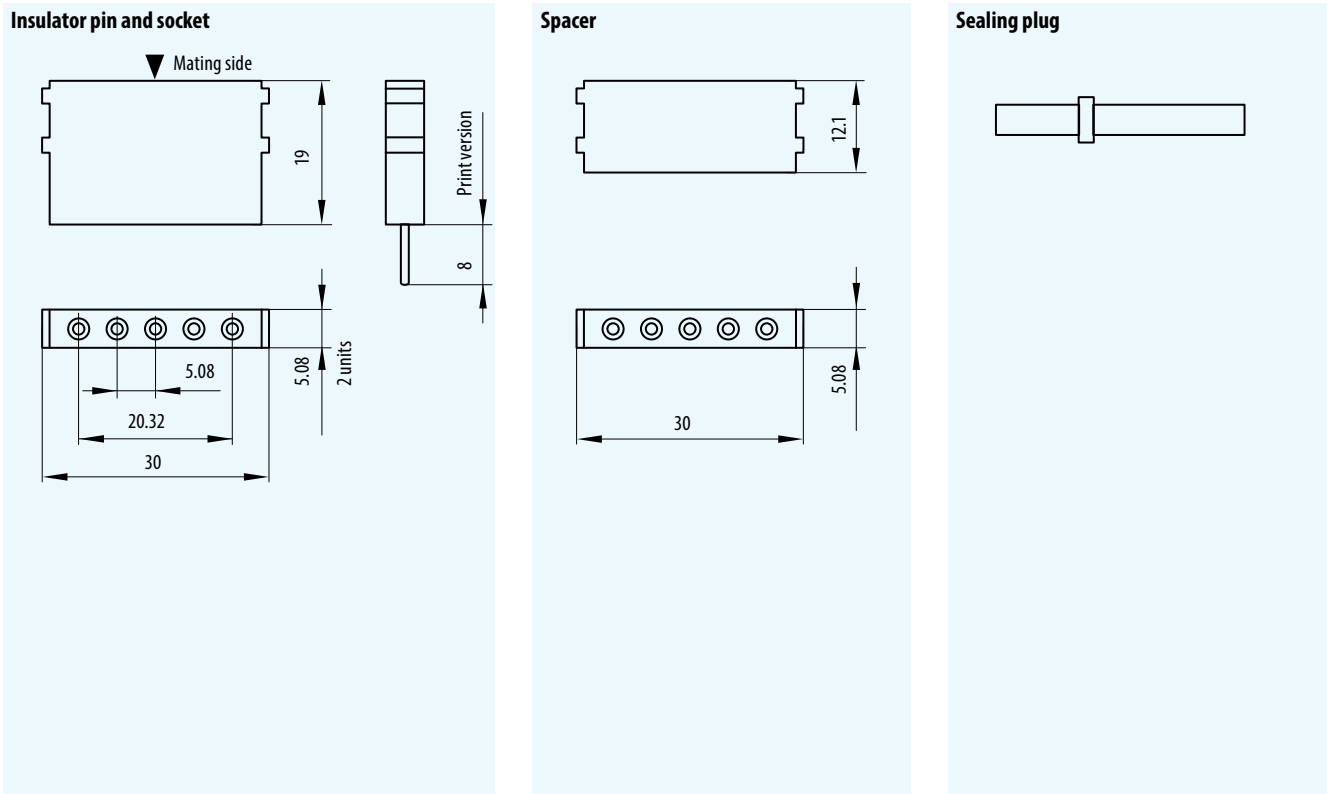

Modules

	Part number	Conductor cross-section mm ²	Termination AWG / mm	Nominal current ²⁾		Contact resistance average mΩ
				Single contact A	Fully equipped module A	
Insulator	611.124.105.923.000					
Spacer	611.124.111.923.000					
Pin contact short ¹⁾	180.363.000.307.000	1.50	14	18.0	14.5	0.95
Pin contact long ¹⁾	180.383.000.307.000					
Socket contact ¹⁾	170.363.700.201.000					
Pin contact short	180.543.000.307.000	1.00	16	18.0	14.5	0.95
Pin contact long	180.573.000.307.000					
Socket contact	170.543.700.201.000					
Pin contact short ¹⁾	180.545.000.307.000	0.50 / 0.38	18	16.0	13.0	0.95
Pin contact long ¹⁾	180.575.000.307.000					
Socket contact ¹⁾	170.545.700.201.000					
Pin contact short ¹⁾	180.541.000.307.000	0.25 / 0.08	20 / 22	10.0	8.0	0.95
Pin contact long ¹⁾	180.571.000.307.000					
Socket contact ¹⁾	170.541.700.201.000					
Pin contact short	180.857.000.307.000	0.25 / 0.08	24 / 28	6.0	6.0	0.95
Pin contact long	180.856.000.307.000					
Socket contact	170.857.700.201.000					
Pin contact short	180.539.000.307.000		Print termination ∅ 1.5 mm	18.0	14.5	0.95
Pin contact long	180.569.000.307.000					
Socket contact	170.539.700.201.000					
Sealing plug	021.341.125.923.000					

¹ Non-magnetic version on request.

² Determined to DIN 60512-5-1:2002 with 45 K increase of temperature.

Module 4 Positions

Technical data

Voltage information ¹⁾

Operating voltage	500V	200V
Rated impulse voltage	3,000V	3,000V
Pollution degree	2	3

Voltage information acc. to MIL ²⁾

Operating voltage	1,100V
Test voltage	3,300V

Mechanical data

Total mating force (average)	27.0 N/module
Total demating force (average)	21.0 N/module
Contact diameter	2.41 mm
Operating temperature	-40° C to +125° C
Mating cycles	min. 100,000

Materials

Insulator	Thermoplast, polyester fibre-glass reinforced acc. UL-94
Contact body	Cu alloy
Contact spring	Cu Sn
Contact finish	3 µm Ag

Technical details

- The current load information is valid for single contacts or fully equipped modules, accordingly. For use in connector systems, the load should be reduced according to VDE 0298.
- Crimp information: see page [108](#).

¹ Acc. DIN EN 60664.1 : 2007 (VDE 0110 part 1). See page [118](#)

² See from page [121](#)



Removal tool I (straight)

Removal of already assembled contacts (including cable).
Part number 087.170.139.000.000



Removal tool II

Removal of contacts that have not been assembled yet (without cable – may have to be cut off).
Part number 087.611.001.001.000

Module 4 positions

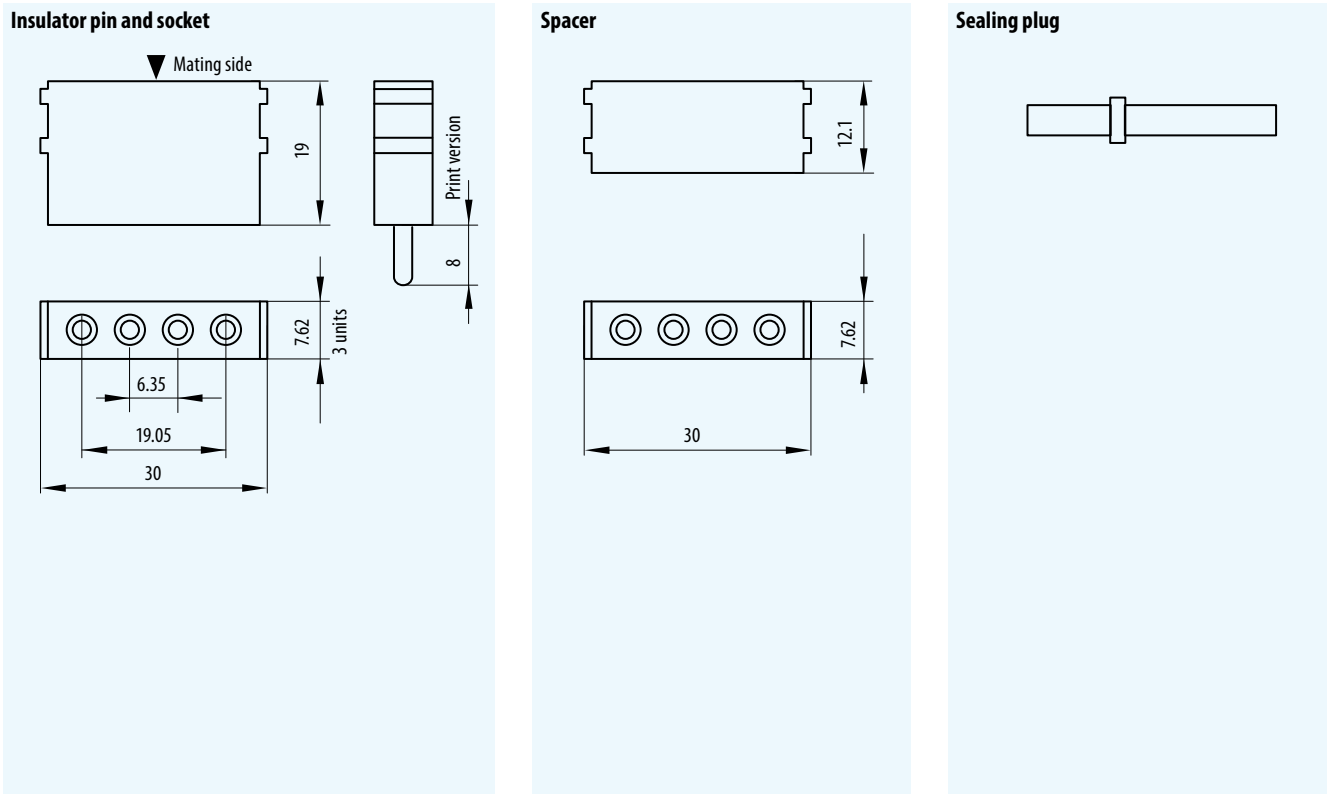

Modules

	Part number	Conductor cross-section mm ²	Termination AWG / mm	Nominal current ²⁾		Contact resistance average mΩ
				Single contact A	Fully equipped module A	
Insulator	611.126.104.923.000					
Spacer	611.126.111.923.000					
Pin contact short	180.365.000.301.000					
Pin contact long	180.385.000.301.000		12	28.0	25.0	0.45
Socket contact	170.365.100.201.000					
Pin contact short ¹⁾	180.910.000.301.000					
Pin contact long ¹⁾	180.911.000.301.000	2.50		24.0	19.0	0.45
Socket contact ¹⁾	170.910.100.201.000					
Pin contact short	182.607.000.301.000					
Pin contact long	182.604.000.301.000	1.50	14	18.0	15.0	0.45
Socket contact	172.604.100.201.000					
Pin contact short	182.606.000.301.000					
Pin contact long	182.603.000.301.000	1.00	18	16.0	13.0	0.45
Socket contact	172.603.100.201.000					
Pin contact short	182.608.000.301.000					
Pin contact long	182.605.000.301.000	0.50 / 0.38	20 / 22	10.5	8.0	0.55
Socket contact	172.605.100.201.000					
Pin contact short	180.820.000.301.000					
Pin contact long	180.821.000.301.000		Print termination ∅ 2.4 mm	28.0	25.0	0.65
Socket contact	170.820.100.201.000					
Sealing plug	021.341.127.923.000					

¹ Non-magnetic version on request.

² Determined to DIN 60512-5-1:2002 with 45 K increase of temperature.

Module 3 Positions

Technical data

Voltage information ¹⁾

Operating voltage	500V	200V
Rated impulse voltage	3,000V	3,000V
Pollution degree	2	3

Voltage information acc. to MIL ²⁾

Operating voltage	1,200V
Test voltage	3,600V

Mechanical data

Total mating force (average)	36.0 N/module
Total demating force (average)	24.75 N/module
Contact diameter	3.0 mm
Operating temperature	-40° C to +125° C
Mating cycles	min. 100,000

Materials

Insulator	Thermoplast, polyester fibre-glass reinforced acc. UL-94
Contact body	Cu alloy
Contact spring	Cu Sn
Contact finish	3 µm Ag

Technical details

- The current load information is valid for single contacts or fully equipped modules, accordingly. For use in connector systems, the load should be reduced according to VDE 0298.
- Crimp information: see page [108](#).

¹⁾ Acc. DIN EN 60664.1 : 2007 (VDE 0110 part 1). See page [118](#)

²⁾ See from page [121](#)



Removal tool I (straight)

Removal of already assembled contacts (including cable).
Part number 087.170.136.000.000



Removal tool I (angled)

Removal of already assembled contacts (including cable).
Part number 087.170.366.000.000



Removal tool II

Removal of contacts that have not been assembled yet (without cable – may have to be cut off).
Part number 087.611.001.001.000

Module 3 positions

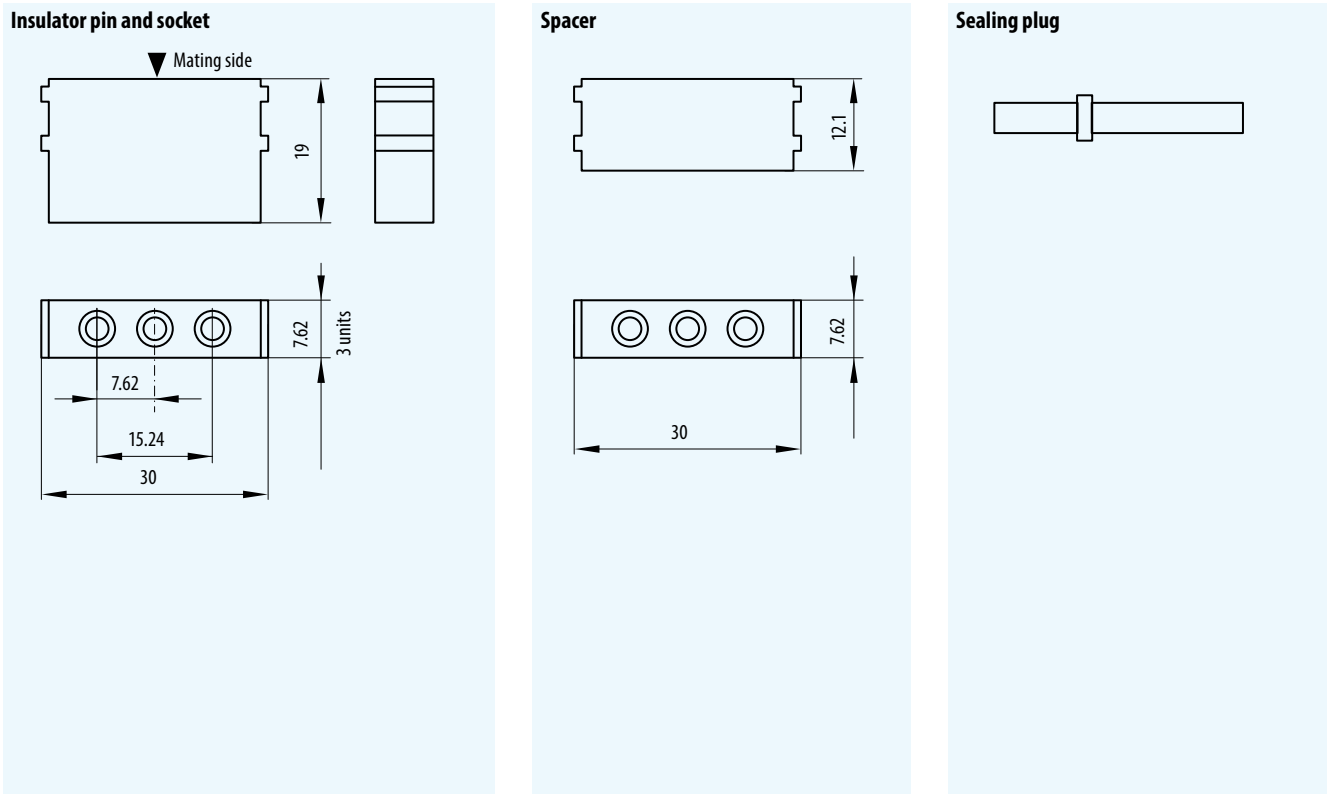

Modules

	Part number	Conductor cross-section mm ²	Termination AWG	Nominal current ²⁾		Contact resistance average mΩ
				Single contact A	Fully equipped module A	
Insulator	611.127.103.923.000					
Spacer	611.127.111.923.000					
Pin contact short	182.980.000.301.000					
Pin contact long	182.981.000.301.000	6.00		39.0	30.0	0.30
Socket contact	172.978.100.201.000					
Pin contact short ¹⁾	180.366.000.301.000					
Pin contact long ¹⁾	180.386.000.301.000	4.00		39.0	30.0	0.30
Socket contact ¹⁾	172.366.100.201.000					
Pin contact short	180.546.000.301.000					
Pin contact long	180.576.000.301.000	2.50		25.0	21.0	0.30
Socket contact	170.546.100.201.000					
Pin contact short ¹⁾	182.582.000.301.000					
Pin contact long	182.583.000.301.000	1.50	14	19.0	16.0	0.30
Socket contact ¹⁾	172.582.100.201.000					
Pin contact short	182.584.000.301.000					
Pin contact long ¹⁾	182.585.000.301.000	1.00	18	16.5	14.0	0.30
Socket contact ¹⁾	172.584.100.201.000					
Pin contact short	182.586.000.301.000					
Pin contact long	182.587.000.301.000	0.50 / 0.38	20 / 22	11.5	9.5	0.40
Socket contact	172.586.100.201.000					
Sealing plug	021.341.128.923.000					

¹ Non-magnetic version on request.

² Determined to DIN 60512-5-1:2002 with 45 K increase of temperature.

Module 2 Positions

Technical data

Voltage information ¹⁾

Operating voltage	1,000V	250V
Rated impulse voltage	4,000V	4,000V
Pollution degree	2	3

Voltage information acc. to MIL ²⁾

Operating voltage	1,250V
Test voltage	3,750V

Mechanical data

Total mating force (average)	51.0 N/module
Total demating force (average)	36.0 N/module
Contact diameter	5.0 mm
Operating temperature	-40° C to +125° C
Mating cycles	min. 100,000

Materials

Insulator	Thermoplast, polyester fibre-glass reinforced acc. UL-94
Contact body	Cu alloy
Contact spring	Cu Sn
Contact finish	3 µm Ag

Technical details

- The current load information is valid for single contacts or fully equipped modules, accordingly. For use in connector systems, the load should be reduced according to VDE 0298.
- Crimp information: see page [108](#).

¹⁾ Acc. DIN EN 60664.1 : 2007 (VDE 0110 part 1). See page [118](#)

²⁾ See from page [121](#)

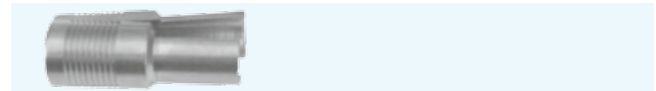

Removal tool

Removal of already assembled contacts (including cable).
Part number 087.170.391.000.000

Module 2 positions

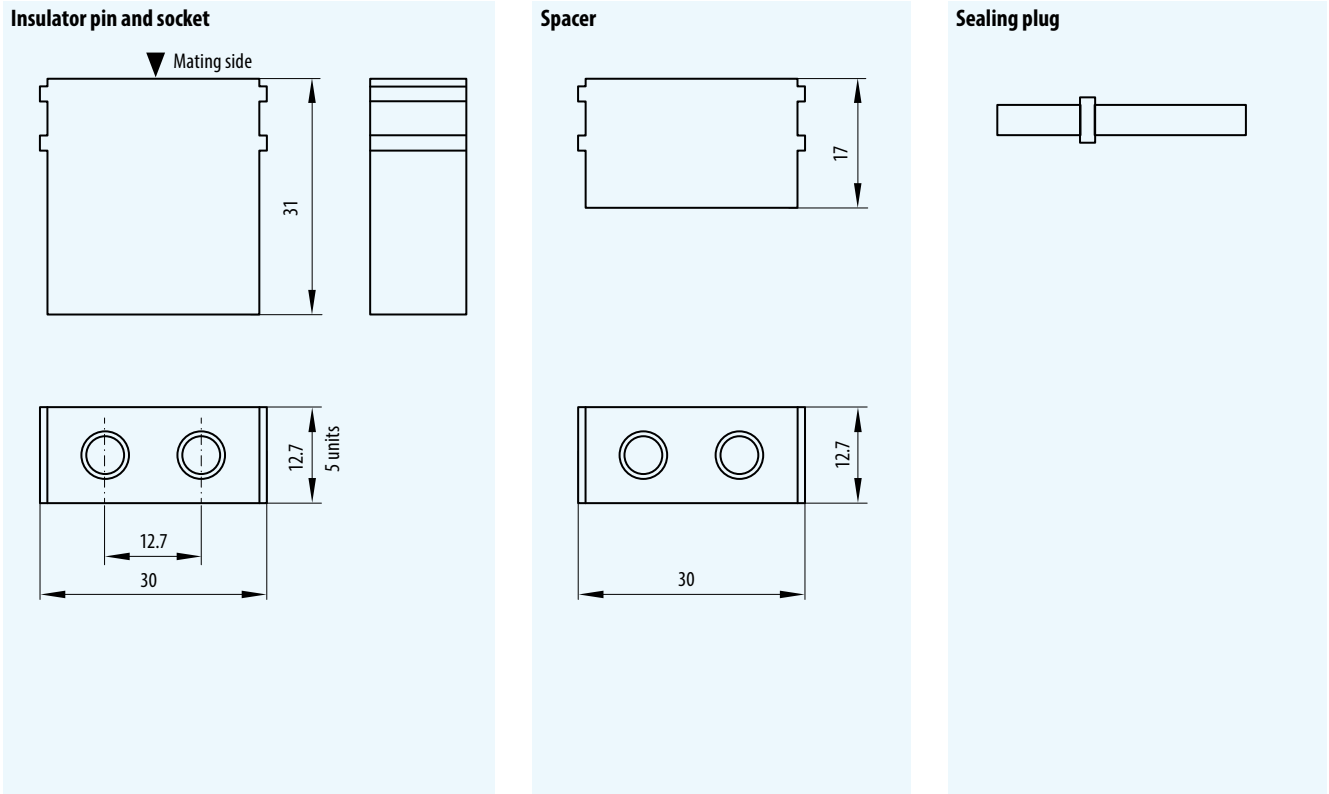

Modules

	Part number	Conductor cross-section mm ²	Nominal current ¹⁾		Contact resistance average mΩ
			Single contact A	Fully equipped module A	
Insulator	611.129.102.923.000				
Spacer	611.129.111.923.000				
Pin contact short	182.891.000.301.000				
Pin contact long	182.892.000.301.000	16.00	80	70	0.21
Socket contact	172.891.100.201.000				
Pin contact short	180.490.000.301.000				
Pin contact long	180.491.000.301.000	10.00	57	57	0.21
Socket contact	170.490.100.201.000				
Pin contact short	180.369.000.301.000				
Pin contact long	180.389.000.301.000	4.00	39	34	0.21
Socket contact	170.369.100.201.000				
Sealing plug	021.341.130.923.000				

¹⁾ Determined to DIN 60512-5-1:2002 with 45 K increase of temperature.

Module 4 Positions, High Voltage Module

Technical data

Voltage information ¹⁾

Operating voltage	2,500V	1,000V
Rated impulse voltage	10,000V	8,000V
Pollution degree	2	3

Voltage information acc. to MIL ²⁾

Operating voltage	2,500V
Test voltage	7,500V

Mechanical data

Total mating force (average)	18.0 N/module
Total demating force (average)	12.0 N/module
Contact diameter	1.5 mm
Operating temperature	-40° C to +125° C
Mating cycles	min. 100,000

Materials

Insulator	Thermoplast, polyester fibre-glass reinforced acc. UL-94
Contact body	Cu alloy
Contact spring	Cu Sn
Contact finish	
- Contact body	0.75 µm Au over 1.25 µm Ni
- Contact spring	3 µm Ag



Technical details

- The current load information is valid for single contacts or fully equipped modules, accordingly. For use in connector systems, the load should be reduced according to VDE 0298.
- Crimp information: see page [108](#).

¹ Acc. DIN EN 60664.1 : 2007 (VDE 0110 part 1). See page [118](#)

² See from page [121](#)



Removal tool I (straight)

Removal of already assembled contacts (including cable).
Part number 087.170.138.000.000



Removal tool II

Removal of contacts that have not been assembled yet (without cable – may have to be cut off).
Part number 087.611.001.001.000

Module 4 Positions, High Voltage Module

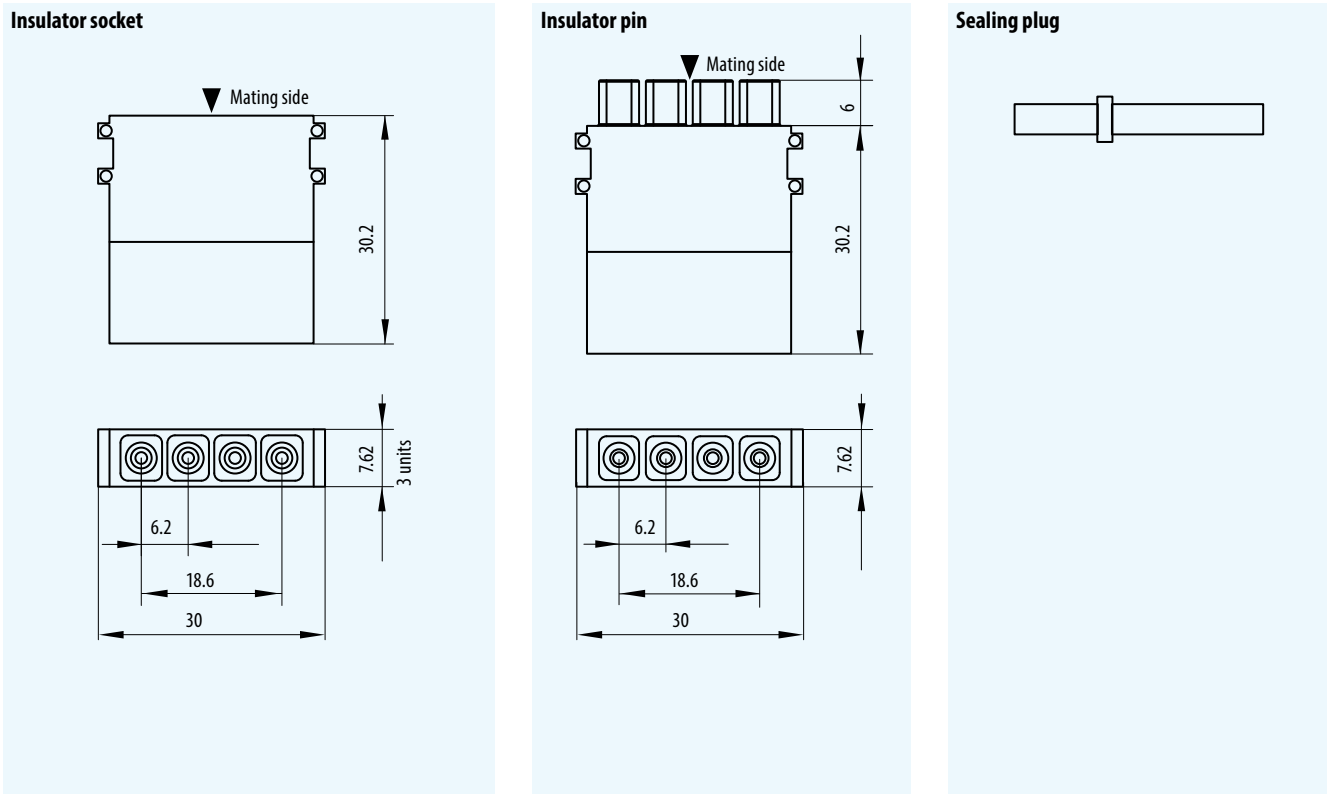

Modules

	Part number	Conductor cross-section		Nominal current ²⁾		Contact resistance average mΩ
		mm ²	AWG/mm	Single contact A	Fully equipped module A	
Insulator socket	610.159.104.923.000					
Insulator pin	611.159.104.923.000					
Spacer	611.126.111.923.000					
Pin contact short ¹⁾	180.363.000.307.000	1.50	14	18.0	14.5	0.95
Pin contact long ¹⁾	180.383.000.307.000					
Socket contact ¹⁾	170.363.700.201.000					
Pin contact short	180.543.000.307.000	1.0	16	18.0	14.5	0.95
Pin contact long	180.573.000.307.000					
Socket contact	170.543.700.201.000					
Pin contact short ¹⁾	180.545.000.307.000	0.50/0.38	20/22	10.0	8.0	0.95
Pin contact long ¹⁾	180.575.000.307.000					
Socket contact ¹⁾	170.545.700.201.000					
Pin contact short ¹⁾	180.541.000.307.000	0.25/0.08	24/28	6.0	6.0	0.95
Pin contact long ¹⁾	180.571.000.307.000					
Socket contact ¹⁾	170.541.700.201.000					
Pin contact short	180.857.000.307.000		Print termination ∅ 1.5 mm	18.0	14.5	0.95
Pin contact long	180.856.000.307.000					
Socket contact	170.857.700.201.000					
Pin contact short	180.539.000.307.000					
Pin contact long	180.569.000.307.000					
Socket contact	170.539.700.201.000					
Sealing plug	021.341.125.923.000					

¹ Non-magnetic version on request.

² Determined to DIN 60512-5-1:2002 with 45 K increase of temperature.

Module 3 Positions, Power Module

Technical data

Voltage information ¹⁾

Operating voltage	2,500V	1,000V
Rated impulse voltage	10,000V	8,000V
Pollution degree	2	3

Voltage information acc. to MIL ²⁾

Operating voltage	2,500V
Test voltage	7,500V

Mechanical data

Total mating force (average)	23.1 N/module
Total demating force (average)	19.6 N/module
Contact diameter	3.0 mm
Operating temperature	-40° C to +125° C acc. UL 1977, second edition, max. 75° C
Mating cycles	min. 100,000

Materials

Insulator	Thermoplast, Polyester fibre-glass reinforced acc. UL-94
Contact body	Cu alloy
Contact spring	Cu Sn
Contact finish	3 µm Ag

Technical details

- The current load information is valid for single contacts or fully equipped modules, accordingly. For use in connector systems, the load should be reduced according to VDE 0298.
- Crimp information: see page [108](#).

¹ Acc. DIN EN 60664.1 : 2007 (VDE 0110 part 1). See page [118](#)

² See from page [121](#)



Removal tool I (straight)

Removal of already assembled contacts (including cable).
Part number 087.170.136.000.000



Removal tool II

Removal of contacts that have not been assembled yet
(without cable – may have to be cut off).
Part number 087.611.001.001.000

Module 3 positions, power module

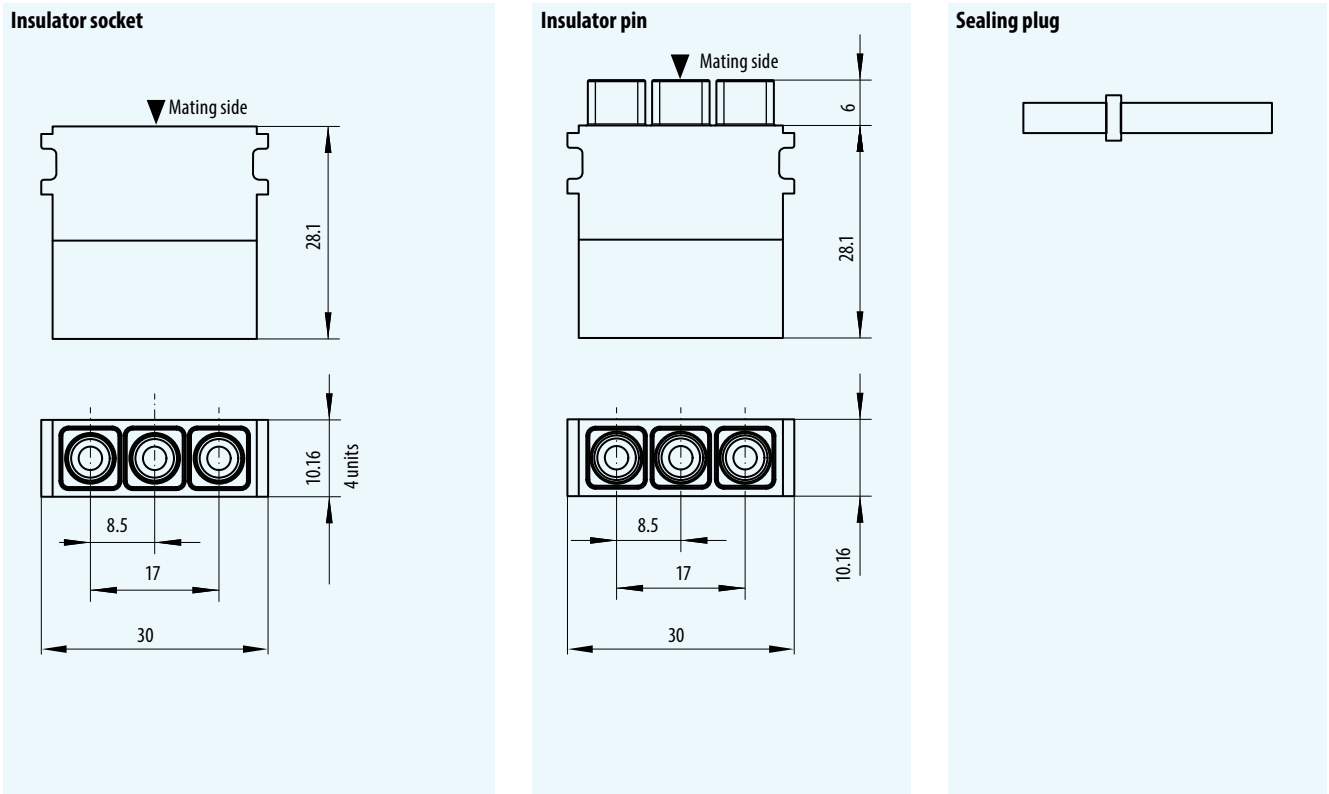

Modules

	Part number	Conductor cross-section		Nominal current ²⁾		Contact resistance average mΩ
		mm ²	AWG	Single contact A	Fully equipped module A	
Insulator socket	610.162.103.923.000					
Insulator pin	611.162.103.923.000					
Pin contact	182.980.000.301.000					
Pin contact long	182.981.000.301.000	6.00		39.0	30.0	0.30
Socket contact	172.978.100.201.000					
Pin contact ¹⁾	180.366.000.301.000					
Pin contact long ¹⁾	180.386.000.301.000	4.00		39.0	30.0	0.30
Socket contact ¹⁾	172.366.100.201.000					
Pin contact	180.546.000.301.000					
Pin contact long	180.576.000.301.000	2.50		25.0	21.0	0.30
Socket contact	170.546.100.201.000					
Pin contact ¹⁾	182.582.000.301.000					
Pin contact long	182.583.000.301.000	1.50	14	19.0	16.0	1.00
Socket contact ¹⁾	172.582.100.201.000					
Pin contact	182.584.000.301.000					
Pin contact long ¹⁾	182.585.000.301.000	1.00	18	16.5	14.0	1.00
Socket contact ¹⁾	172.584.100.201.000					
Pin contact	182.586.000.301.000					
Pin contact long	182.587.000.301.000	0.50 / 0.38	20 / 22	11.5	9.5	1.00
Socket contact	172.586.100.201.000					
Sealing plug	021.341.128.923.000					

¹ Non-magnetic version on request.

² Determined to DIN 60512-5-1:2002 with 45 K increase of temperature.

Module 2 Positions for Power Contacts ODU LAMTAC® (Contacts with Lamella Technology)

Technical data

Voltage information ¹⁾

Operating voltage	500V	200V
Rated impulse voltage	3,000V	3,000V
Pollution degree	2	3

Voltage information acc. to MIL ²⁾

Operating voltage	900V
Test voltage	2,700V

Mechanical data

Total mating force (average)	60.0N/module
Total demating force (average)	45.0 N/module
Contact diameter	8.0 mm
Operating temperature	-40°C to +125°C
Mating cycles	min. 10,000

Materials

Insulator	Thermoplast, polyester fibre-glass reinforced acc. UL-94
Contact body	Cu alloy
Contact lamella	Cu Be
Contact finish	3 µm Ag

Technical details

- The current load information is valid for single contacts or fully equipped modules, accordingly. For use in connector systems, the load should be reduced according to VDE 0298.
- Crimp information: see page [108](#).



Assembly tool

To screw down the contacts.
Part number 087.611.002.001.000
Tightening torque: 3.5 Nm ± 0.5 Nm

¹ Acc. DIN EN 60664.1 : 2007 (VDE 0110 part 1). See page [118](#)

² See from page [121](#)

Module 2 positions for power contacts ODU LAMTAC® (contacts with lamella technology)

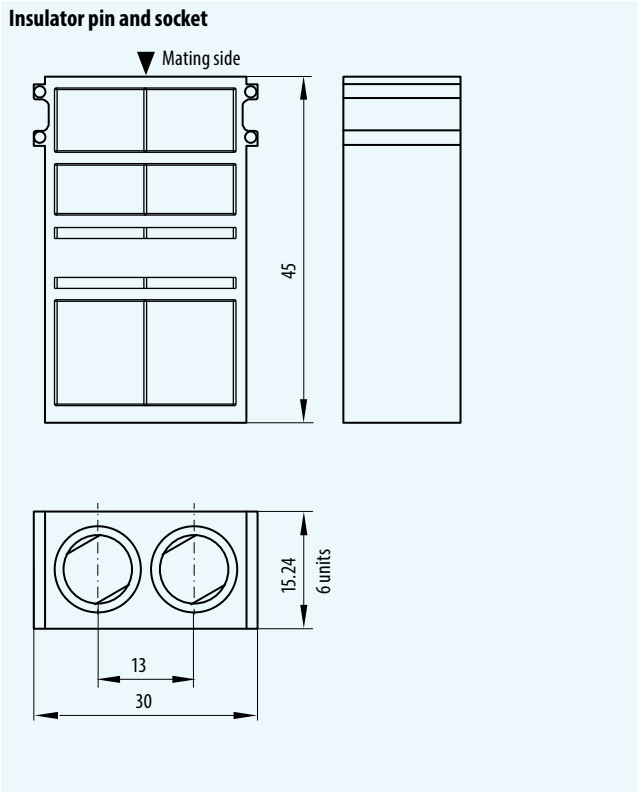

ODU LAMTAC® (contacts with lamella technology)

The ODU LAMTAC® contact offers fewer contact surfaces than does the ODU SPRINGTAC® contact. One or more stamped lamellas are mounted into a turned carrier. At least 10,000 mating cycles are possible.

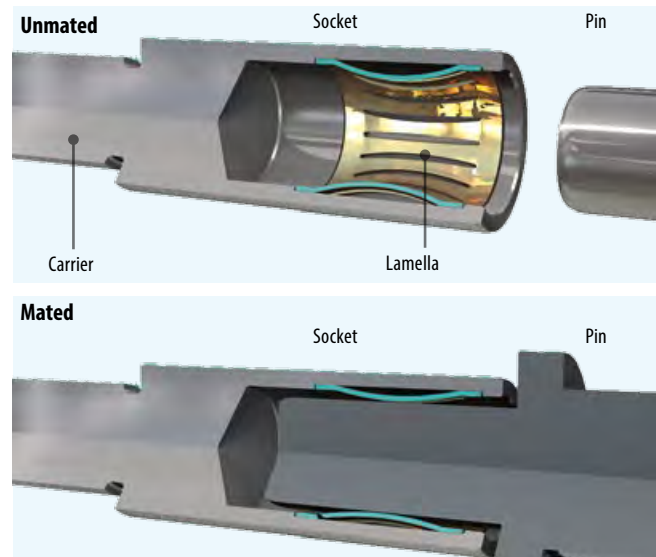

Modules

	Part number	Conductor cross-section ²⁾ mm ²	Nominal current ¹⁾		Contact resistance average mΩ
			Single contact A	Fully equipped module A	
Insulator	611.161.102.923.000				
Pin contact	181.874.100.200.000	25.00	105	100	0.2
Socket contact	178.874.100.201.000				
Pin contact	181.875.100.200.000	16.00	90	85	0.2
Socket contact	178.875.100.201.000				

¹ Determined to DIN 60512-5-1:2002 with 45 K increase of temperature.

² Extra fine wires according to VDE 0295, class 5

Module 2 Positions for Power Contacts ODU SPRINGTAC® (Contacts with Springwire Technology)

Technical data

Voltage information ¹⁾

Operating voltage	500V	200V
Rated impulse voltage	3,000V	3,000V
Pollution degree	2	3

Voltage information acc. to MIL ²⁾

Operating voltage	700V
Test voltage	2,100V

Mechanical data

Total mating force (average)	approx. 60 N/module
Total demating force (average)	approx. 39.0 N/module
Contact diameter	8.0 mm
Operating temperature	-40° C to +125° C
Mating cycles	min. 100,000

Materials

Insulator	Thermoplast, polyester fibre-glass reinforced acc. UL-94
Contact	Cu alloy
Contact spring	Cu Sn
Contact finish	3 µm Ag

Technical details

– The current load information is valid for single contacts or fully equipped modules, accordingly. For use in connector systems, the load should be reduced according to VDE 0298.

¹⁾ Acc. DIN EN 60664.1 : 2007 (VDE 0110 part 1). See page 118

²⁾ See from page 121



Assembly tool

To screw down the contacts.
Part number 087.611.002.001.000
Tightening torque: 3.5 Nm ± 0.5 Nm

Module 2 positions for power contacts ODU SPRINGTAC® (contacts with springwire technology)

Insulator socket and pin

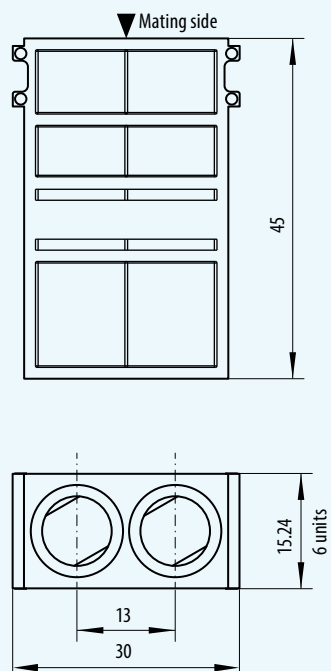

Modules

	Part number	Conductor ²⁾ cross-section mm ²	Nominal current ¹⁾		Contact resistance average mΩ
			Single contact A	Fully equipped module A	
Insulator	611.173.102.923.000				
Pin contact	181.873.100.200.000	25.00	100	95	0.2
Socket contact	170.045.100.201.000				
Pin contact	181.872.100.200.000	16.00	75	70	0.2
Socket contact	171.045.100.201.000				

¹ Determined to DIN 60512-5-1:2002 with 45 K increase of temperature.

² Extra fine wires according to VDE 0295, class 5

Module 1 Position for Power Contacts ODU LAMTAC® (Contacts with Lamella Technology)

Technical data

Voltage information ¹⁾

Contact diameter	10 mm or 12 mm	
Operating voltage		
– Ø 10 mm	250V	160V
– Ø 12 mm	200V	63V
Rated impulse voltage		
– Ø 10 mm	4,000V	4,000V
– Ø 12 mm	3,000V	3,000V
Pollution degree		
– Ø 10 mm	2	3
– Ø 12 mm	2	3

Voltage information acc. to MIL ²⁾

Operating voltage	
– Ø 10 mm	2,000V
– Ø 12 mm	1,500V
Test voltage	
– Ø 10 mm	6,000V
– Ø 12 mm	4,500V

Mechanical data

Total mating force (average)	
– Ø 10 mm	33.0 N/module
– Ø 12 mm	45.0 N/module
Total demating force (average)	
– Ø 10 mm	24.0 N/module
– Ø 12 mm	30.0 N/module
Operating temperature	–40° C to +125° C
Mating cycles	min. 10,000

Materials

Insulator	Thermoplast, polyester fibre-glass reinforced acc. UL-94
Contact body	Cu alloy
Contact lamella	Cu Be
Contact finish	3 µm gal. Ag



Assembly tool

To screw down the contacts.

Part number Ø 10 mm:	087.611.003.001.000
Part number Ø 12 mm:	087.611.004.001.000
Tightening torque: 3.5 Nm ± 0.5 Nm	

Technical details

- The current load information is valid for single contacts or fully equipped modules, accordingly. For use in connector systems, the load should be reduced according to VDE 0298.
- Crimp information: see page 108.

¹ Acc. DIN EN 60664.1 : 2007 (VDE 0110 part 1). See page 118

² See from page 121

Module 1 position for power contacts ODU LAMTAC® (contacts with lamella technology)

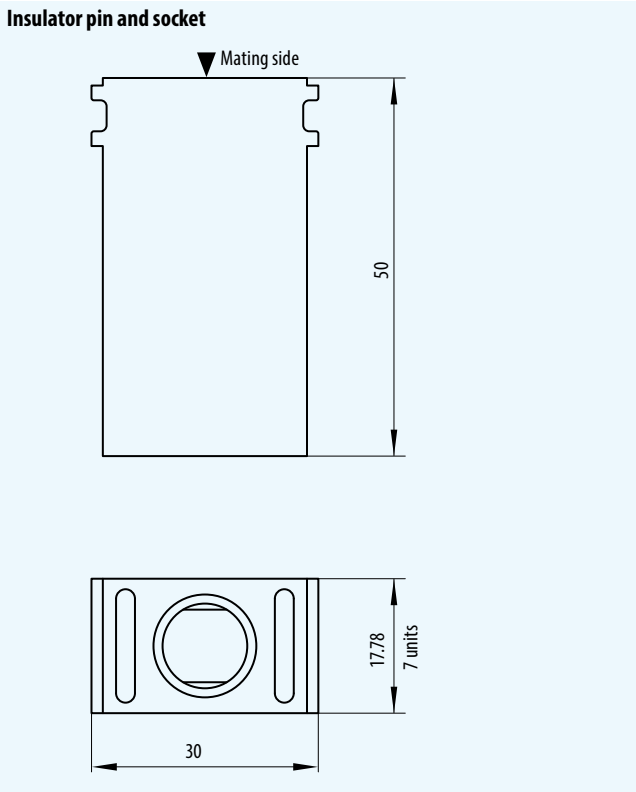

ODU LAMTAC® (contacts with lamella technology)

The ODU LAMTAC® contact offers fewer contact surfaces than does the ODU SPRINGTAC® contact. One or more stamped lamellas are mounted into a turned carrier. Usually 10,000 mating cycles are possible.

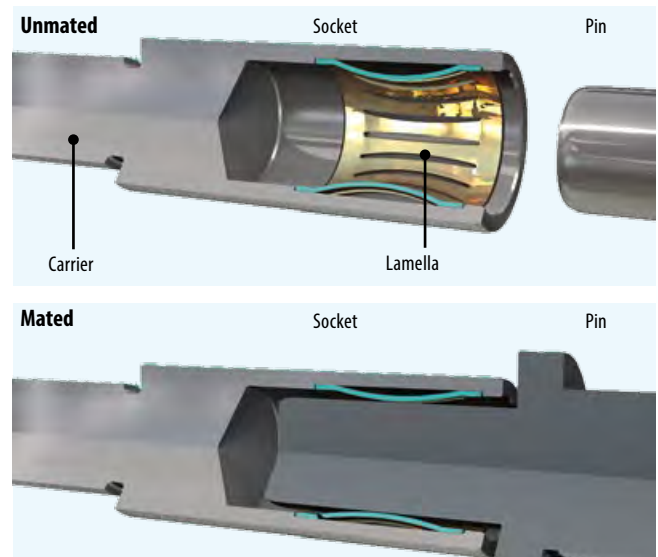

Modules

	Part number	Conductor cross-section ²⁾ mm ²	Nominal current ¹⁾ A	Contact resistance average mΩ
Insulator for contact Ø 10 mm	611.169.101.923.000			
Insulator for contact Ø 12 mm	611.172.101.923.000			
Pin contact Ø 10 mm	181.878.100.200.000	35.00	120	0.15
Socket contact Ø 10 mm	178.878.100.201.000			
Pin contact Ø 10 mm	181.946.100.200.000	25.00	110	0.15
Socket contact Ø 10 mm	178.954.100.201.000			
Pin contact Ø 12 mm	181.943.100.200.000	50.00	145	0.10
Socket contact Ø 12 mm	178.943.100.201.000			
Pin contact Ø 12 mm	181.945.100.200.000	35.00	135	0.10
Socket contact Ø 12 mm	178.953.100.201.000			
Pin contact Ø 12 mm	181.944.100.200.000	25.00	115	0.10
Socket contact Ø 12 mm	178.948.100.201.000			

¹ Determined to DIN 60512-5-1:2002 with 45 K increase of temperature.

² Extra fine wires according to VDE 0295, class 5

Module 1 Position for High Voltage Contacts

Technical data

Voltage information ¹⁾

Operating voltage	6,300V	2,500V
Rated impulse voltage	20,000V	20,000V
Pollution degree	2	3
Clearance distance	>32 mm	
Creepage distance	>32 mm	

Test of the partial discharge voltage (PDV) according to VDE

PDV inception voltage	6,000V
PDV extinction voltage	5,700V

Mechanical data

Total mating force (average)	17.0 N/module
Total demating force (average)	15.0 N/module
Contact diameter	2.0 mm
Operating temperature	-40° C to +125° C
Mating cycles	min. 10,000

Materials

Insulator	Thermoplast, polyester fibre-glass reinforced acc. UL-94
Contact	Cu alloy/PTFE
Contact spring	Cu Be
Contact finish	
- Outer contact	1.25 µm gal. Ni
- Center contact	3.00 µm gal. Ag



Technical details

- The current load information is valid for single contacts or fully equipped modules, accordingly. For use in connector systems, the load should be reduced according to VDE 0298.

¹ Acc. DIN EN 60664.1 : 2007 (VDE 0110 part 1). See page [118](#)

Module 1 position for high voltage contacts

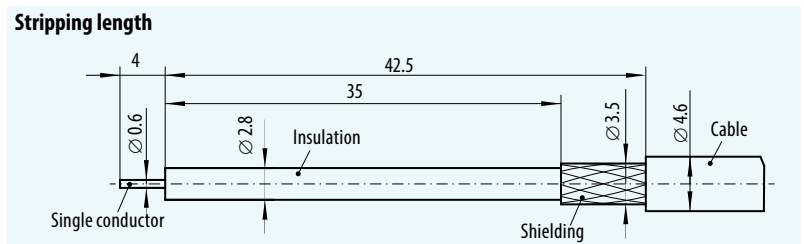
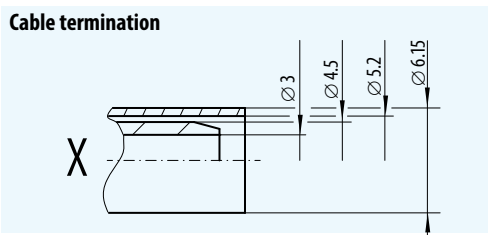
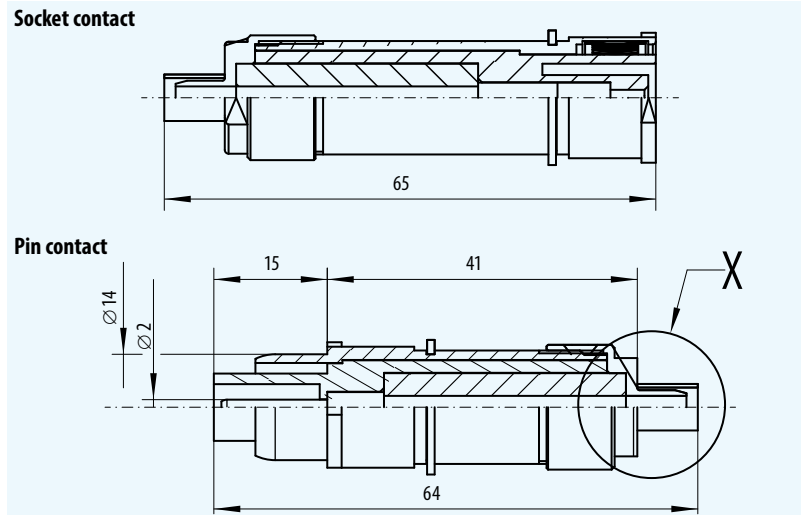
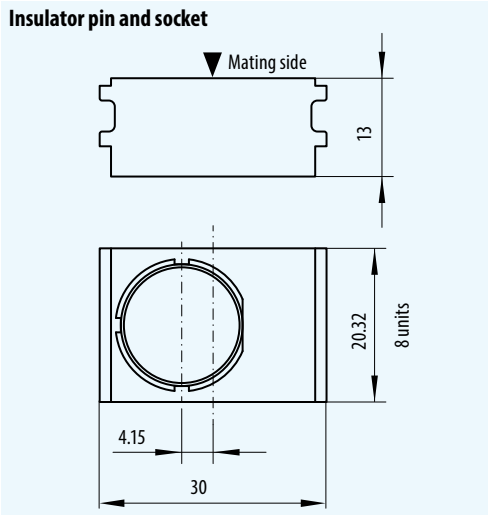

Modules

	Part number	Part number crimp die	Conductor cross-section AWG / mm ²	Maximum nominal current A	Contact resistance average mΩ
Insulator	611.171.101.923.000				
Pin contact	122.138.001.201.000	082.000.039.106.000	22 / 24	3.5	0.40
Socket contact	122.138.002.201.000				
Crimping tool for shielding	080.000.039.000.000				
High voltage cable	921.000.001.000.718		0.25 mm ²		

Module 4 Positions for 50 Ω Coaxial Contacts Non-Magnetic

Technical data

Voltage information

Frequency range ²⁾ 0 – 1.2 GHz
 Insulation resistance > 100 GΩ

Voltage information acc. to MIL ¹⁾

Operating voltage 350V
 Test voltage 1,050V

Mechanical data

Total mating force (average) 17.8 N/module
 Total demating force (average) 15.3 N/module
 Operating temperature –40° C to +125° C
 Mating cycles min. 60,000

Materials

Insulator Thermoplast, polyester fibre-glass reinforced acc. UL-94
 Contacts Cu alloy /PTFE
 0.8 μm Au over
 2.0 μm CuSnZn



Technical details

– Crimp information see page [108](#).

¹ See from page 121

² Loss levels depend on the conductor cross-section. These are available on request.



Removal tool I (angled)

Removal of already assembled contacts (including cable).
 Part number 087.170.365.000.000



Removal tool II

Removal of contacts that have not been assembled yet (without cable – may have to be cut off).
 Part number 087.611.001.001.000

High frequency characteristics for 50 Ω coaxial contacts ²⁾

Insertion loss

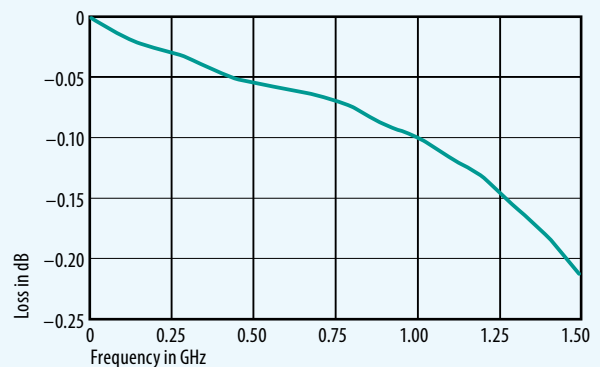

VSWR (voltage standing wave ratio)

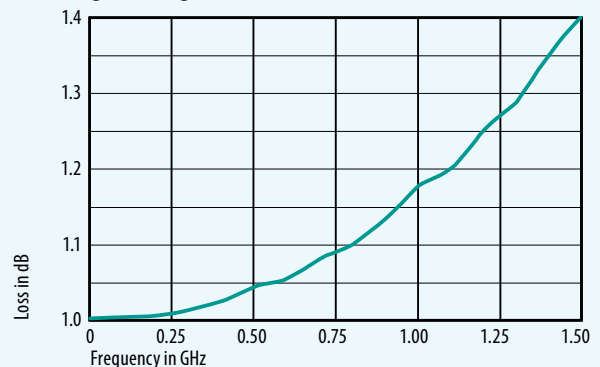

Module 4 positions for 50 Ω coaxial contacts, non-magnetic

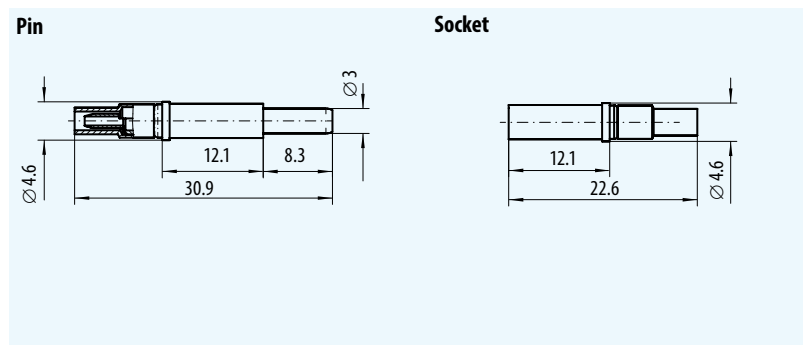
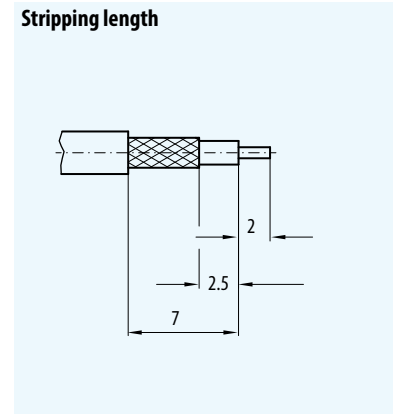
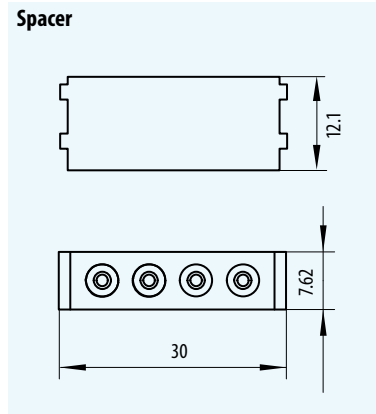
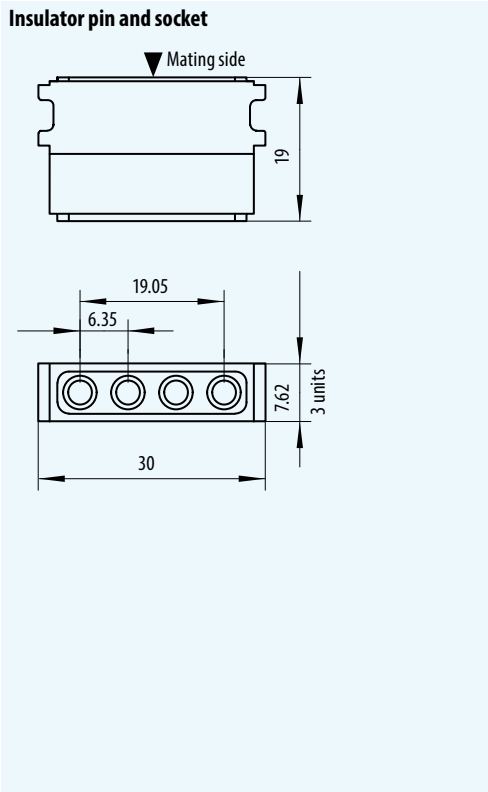

Modules

	Part number	Characteristic impedance Ω	Cable ¹⁾	Part number crimp dies
Insulator	611.149.104.923.000			
Spacer	611.126.111.923.000			
Pin contact straight	122.120.001.257.000	50	RG 178 / RG 196	082.000.039.101.000
Pin contact straight	122.120.003.257.000		RG 174 / RG 188 / RG 316 (75 Ω: RG 179, RG 187)	082.000.039.102.000
Pin contact straight	122.120.011.257.000		G02232 (H+S)	082.000.039.103.000
Socket contact straight	122.120.002.257.000	50	RG 178, RG 196	082.000.039.101.000
Socket contact straight	122.120.004.257.000		RG 174 / RG 188 / RG 316 (75 Ω: RG 179, RG 187)	082.000.039.102.000
Socket contact straight	122.120.012.257.000		G 02232 (H+S)	082.000.039.103.000
Crimping tool for shielding sleeve	080.000.039.000.000			

¹⁾ Special lines on request

Module 2 Positions for 50 Ω Coaxial Contacts

Technical data

Voltage information

Frequency range ²⁾ 0 to 2.5 GHz
 Insulation resistance > 100 GΩ

Voltage information acc. to MIL ¹⁾

Operating voltage 400V
 Test voltage 1,200V

Mechanical data

Total mating force (average) 12.0 N/module
 Total demating force (average) 10.8 N/module
 Operating temperature -40° C to +125° C
 Mating cycles min. 100,000

Materials

Insulator	Thermoplast, polyester fibre-glass reinforced acc. UL-94
Contact body	Cu alloy
Contact spring	Cu Sn
Contact finish	
– Pin center contact	0.75 μm Au over 1.25 μm Ni
– Pin outer contact	6 μm Ni
– Socket center contact	Springs 0.75 μm Au over 1.25 μm Ni
– Socket outer contact	Springs 0.75 μm Au over 1.25 μm Ni



Technical details

– Crimp information see page [108](#).

¹ See from page [121](#)

² Loss levels depend on conductor cross-section. These are available on request.

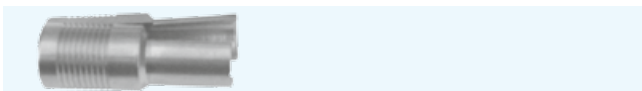

Removal tool I

Part number 087.170.391.000.000

High frequency characteristics for 50 Ω coaxial contacts ²⁾

Insertion loss

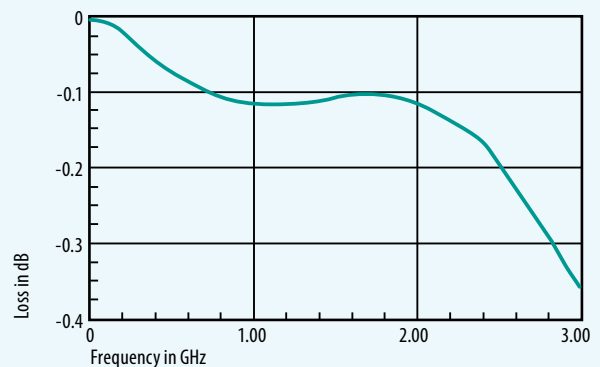

VSWR (voltage standing wave ratio)

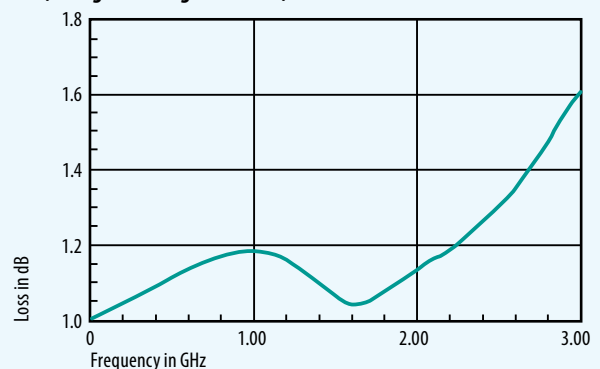

Module 2 positions for 50 Ω coaxial contacts

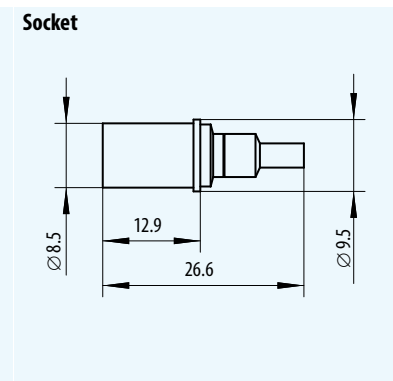
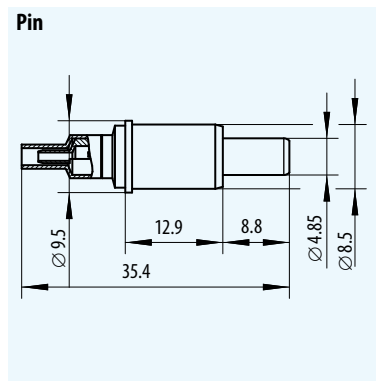
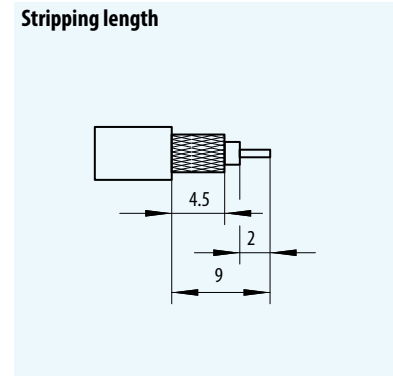
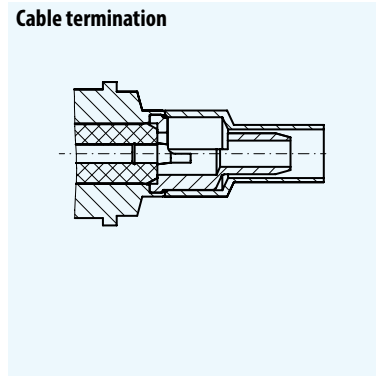
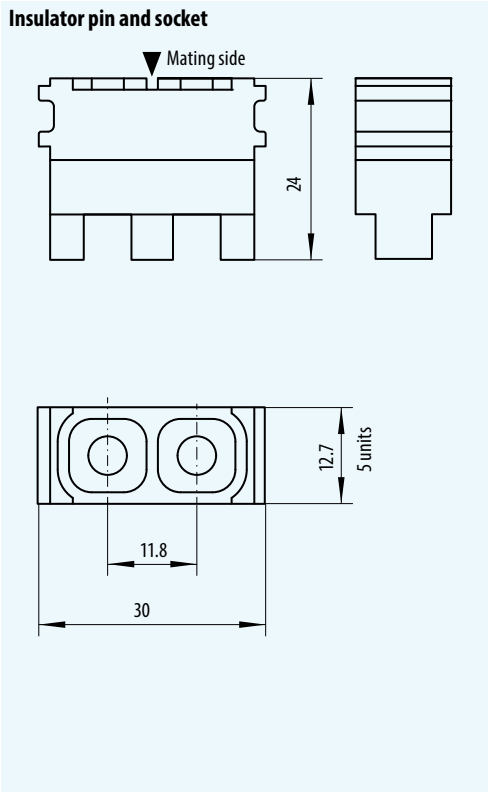

Modules

	Part number	Characteristic impedance Ω	Cable ¹⁾	Part number crimp dies	
Insulator	611.152.102.923.000				
Spacer	611.129.111.923.000				
Sealing plug	021.341.177.300.000				
Pin contact straight	122.346.001.207.000	50	RG 178 / RG 196	082.000.039.101.000	
Pin contact straight	122.346.003.207.000		RG 174 / RG 188 / RG 316	082.000.039.102.000	
Pin contact straight	122.346.005.207.000		RG 122 (2YCY 0.4/2.5-75 Ω)	082.000.039.104.000	
Pin contact straight	122.346.007.207.000		RG 58	082.000.039.106.000	
Pin contact straight	122.346.009.207.000		RG 223	082.000.039.108.000	
Pin contact straight	122.346.011.207.000		G 02232 D (H+S)	082.000.039.103.000	
Socket contact straight	122.346.002.207.000		50	RG 178 / RG 196	082.000.039.101.000
Socket contact straight	122.346.004.207.000			RG 174 / RG188 / RG 316	082.000.039.102.000
Socket contact straight	122.346.006.207.000			RG122 (2YCY 0.4/2.5-75 Ω)	082.000.039.104.000
Socket contact straight	122.346.008.207.000	RG 58		082.000.039.106.000	
Socket contact straight	122.346.010.207.000	RG 223		082.000.039.108.000	
Socket contact straight	122.346.012.207.000	G 02232 D (H+S)		082.000.039.103.000	
Crimping tool for shielding sleeve	080.000.039.000.000				

¹⁾ Special lines on request

Module 2 Positions for 50 Ω Coaxial Contacts SMA Termination

Technical data

Voltage information

Frequency range ²⁾ 0 – 9.0 GHz
 Insulation resistance > 100 GΩ

Voltage information acc. to MIL ¹⁾

Operating voltage 350V
 Test voltage 1,050V

Mechanical data

Total mating force (average) 9.0 N/module
 Total demating force (average) 7.5 N/module
 Operating temperature –40° C to +125° C
 Mating cycles min. 100,000

Materials

Insulator	Thermoplast, polyester fibre-glass reinforced acc. UL-94
Contact body	Cu alloy
Contact spring	Cu Sn
Contact finish	
– Pin center contact	0.75 μm Au over 1.25 μm Ni
– Pin outer contact	6 μm Ni
– Socket center contact	Springs 0.75 μm Au over 1.25 μm Ni
– Socket outer contact	Springs 0.75 μm Au over 1.25 μm Ni

Technical details

– Crimp information see page [108](#).

¹ See from page [121](#)

² Loss levels depend on conductor cross-section. These are available on request.

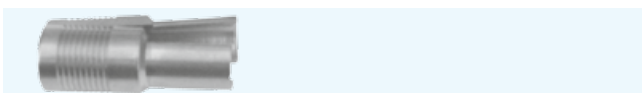

Removal tool

Part number 087.122.349.000.000

High frequency characteristics for 50 Ω coaxial contacts, SMA termination ²⁾

Insertion loss

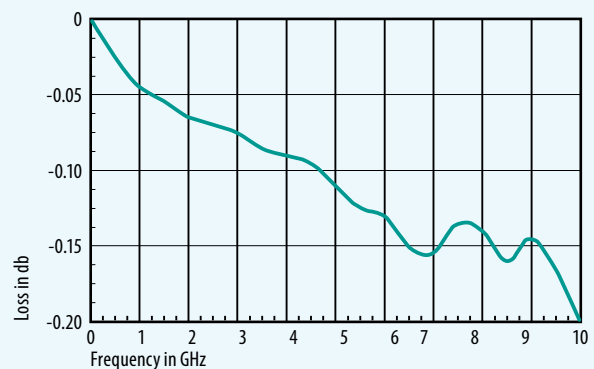

VSWR (voltage standing wave ratio)

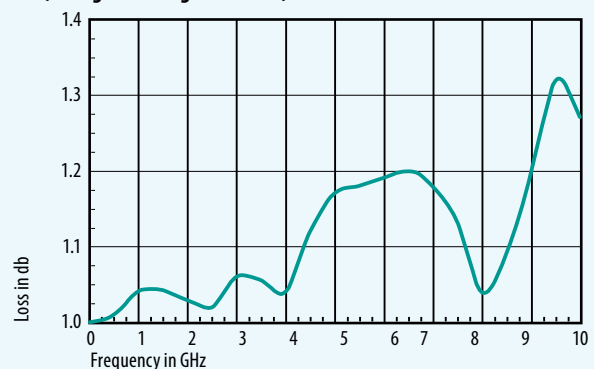

Module 2 positions for 50 Ω coaxial contacts, SMA Termination

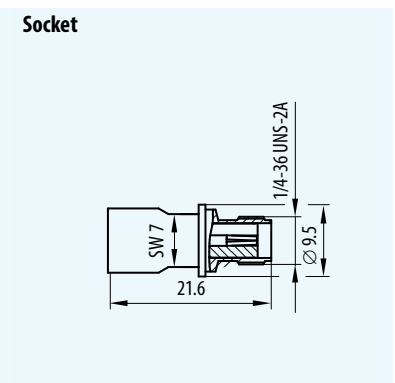
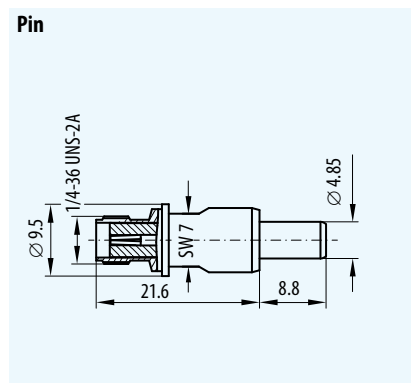
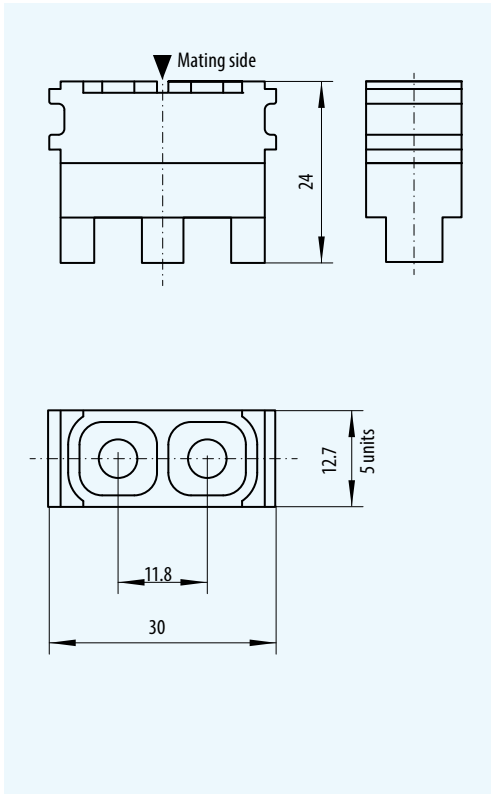

Modules

	Part number	Characteristic impedance Ω	Termination	
Insulator	611.152.102.923.000			
Spacer	611.129.111.923.000			
Sealing plug	021.341.177.300.000			
Pin contact straight	122.349.001.207.000	50	SMA	
Socket contact straight	122.349.002.207.000	50	SMA	

Module 2 Positions for 50 Ω Coaxial Contacts High Voltage, Non-Magnetic

Technical data

Voltage information

Frequency range ²⁾ 0 to 0.25 GHz
 Insulation resistance > 100 GΩ

Voltage information acc. to MIL ¹⁾

Operating voltage 850V
 Test voltage 2,600V

Mechanical data

Total mating force (average) 12.0 N/module
 Total demating force (average) 10.8 N/module
 Operating temperature -40° C to +125° C
 Mating cycles min. 100,000

Materials

Insulator Thermoplast, polyester fibre-glass reinforced acc. UL-94
 Contact Cu alloy
 Surface 2 μm white bronze and 0.8 μm Au



Technical details

– Crimp information see page [108](#).

¹ See from page [121](#)

² Loss levels depend on conductor cross-section. These are available on request.

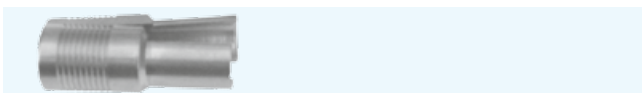

Removal tool

Part number 087.170.391.000.000

High frequency characteristics for 50 Ω coaxial contacts, high voltage, non-magnetic²⁾

Insertion loss

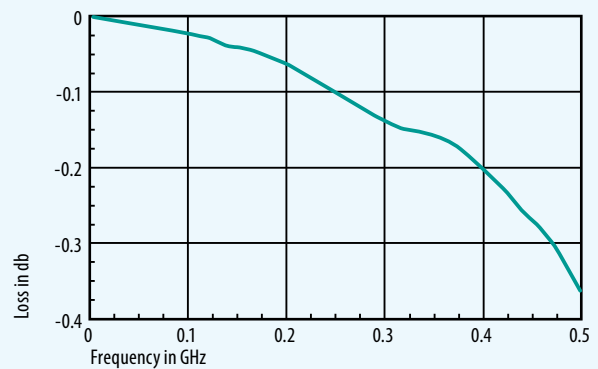

VSWR (voltage standing wave ratio)

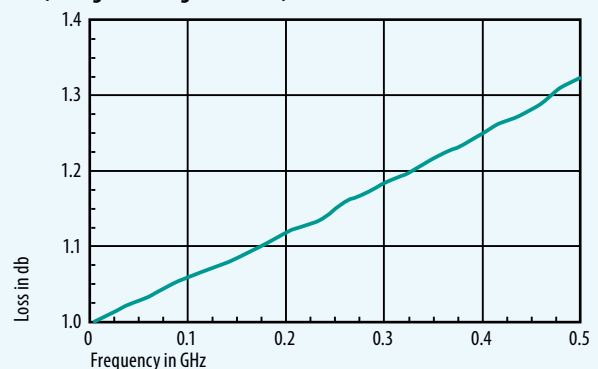

Module 2 positions for 50 Ω coaxial contacts, high voltage, non-magnetic

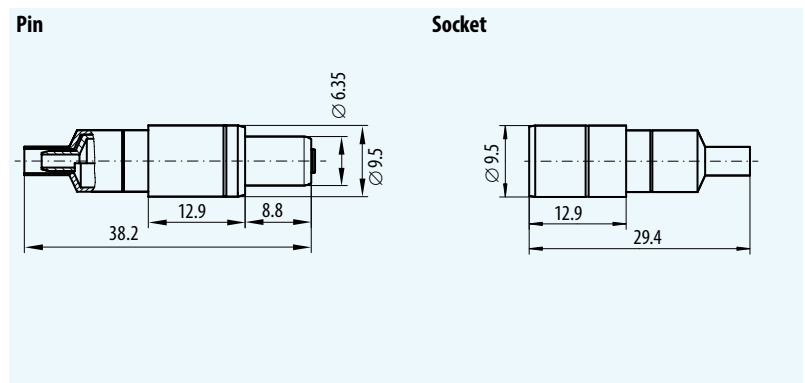
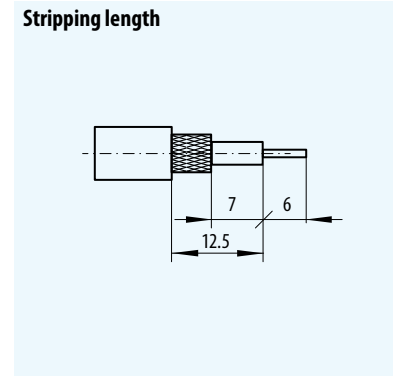
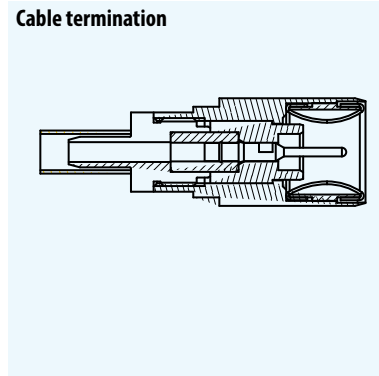
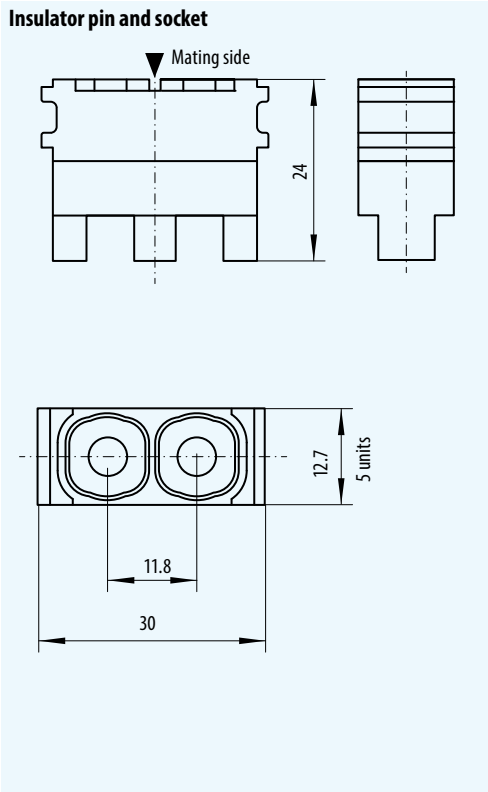

Modules

	Part number	Characteristic impedance Ω	Cable ¹⁾	Part number crimp dies
Insulator	611.155.102.923.000			
Spacer	611.129.111.923.000			
Sealing plug	021.341.179.923.000			
Pin contact straight	122.126.001.257.000	50	RG 178 / RG 196	082.000.039.101.000
Pin contact straight	122.126.003.257.000		RG 174 / RG 188 / RG 316	082.000.039.102.000
Pin contact straight	122.126.009.257.000		RG 223	082.000.039.108.000
Pin contact straight	122.126.007.257.000		RG 58	082.000.039.106.000
Socket contact straight	122.126.002.257.000	50	RG 178 / RG 196	082.000.039.101.000
Socket contact straight	122.126.004.257.000		RG 174 / RG 188 / RG 316	082.000.039.102.000
Socket contact straight	122.126.010.257.000		RG 223	082.000.039.108.000
Socket contact straight	122.126.008.257.000		RG 58	082.000.039.106.000
Crimping tool for shielding sleeve	080.000.039.000.000			

¹⁾ Special lines on request

Module 2 Positions for 75 Ω Coaxial Contacts

Technical data

Voltage information

Frequency range ²⁾ 0 to 2.0 GHz
 Insulation resistance > 100 GΩ

Voltage information acc. to MIL ¹⁾

Operating voltage 475 V
 Test voltage 1,425 V

Mechanical data

Total mating force (average) 9.0 N/module
 Total demating force (average) 7.5 N/module
 Operating temperature -40° C to +125° C
 Mating cycles min. 100,000

Materials:

Insulator Thermoplast, polyester fibre-glass reinforced acc. UL-94

Contact body Cu alloy
 Contact spring Cu Sn

Contact finish

- Pin center contact 0.75 μm Au over 1.25 μm Ni
- Pin outer contact 4 μm Ni
- Socket center contact Springs 0.75 μm Au over 1.25 μm Ni
- Socket outer contact Springs 0.75 μm Au over 1.25 μm Ni

¹ See from page 121

² Loss levels depend on conductor cross-section. These are available on request.

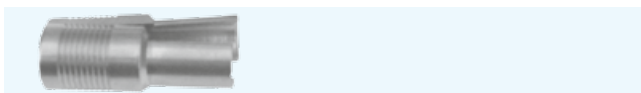

Removal tool

Part number 087.170.391.000.000

High frequency characteristics for 75 Ω coaxial contacts ²⁾

Insertion loss

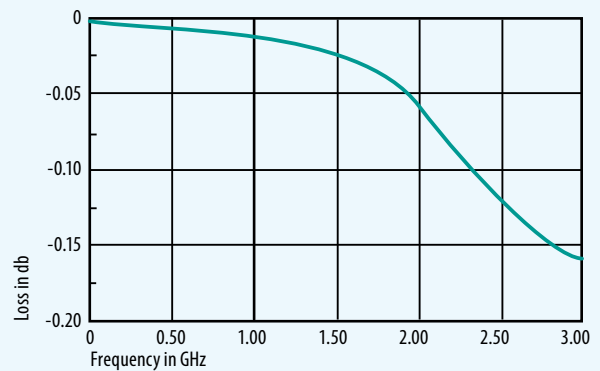

VSWR (voltage standing wave ratio)

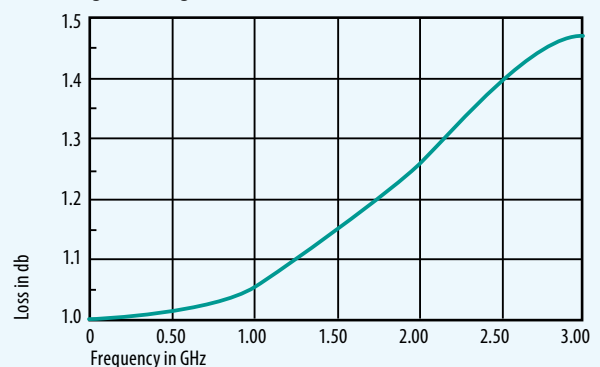

Module 2 positions for 75 Ω coaxial contacts

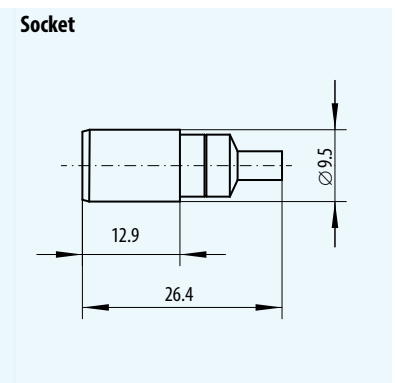
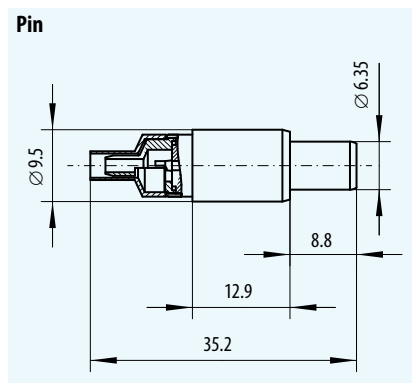
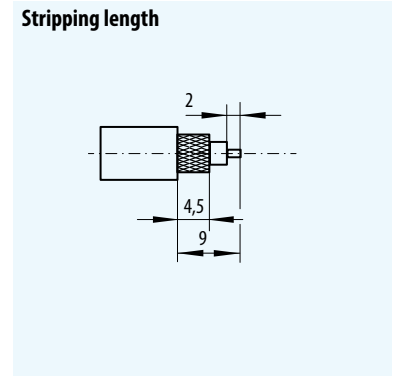
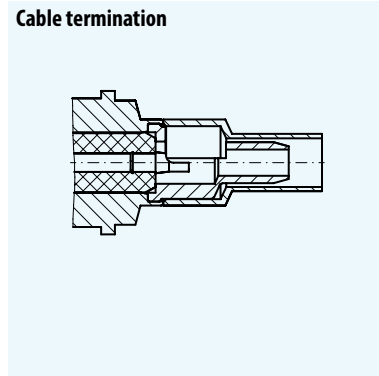
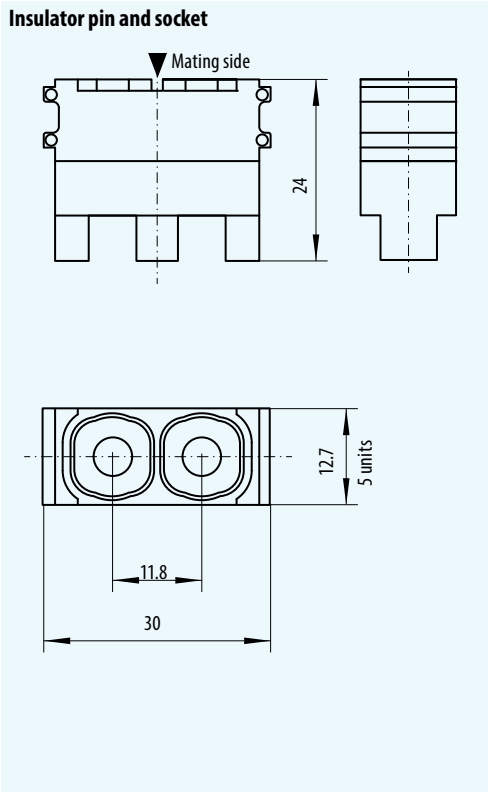

Modules

	Part number	Characteristic impedance Ω	Cable ¹⁾	Part number crimp dies
Insulator	611.155.102.923.000			
Spacer	611.129.111.923.000			
Sealing plug	021.341.179.923.000			
Pin contact straight	122.348.003.207.000	75	RG 179 / RG 187	082.000.039.102.000
Pin contact straight	122.348.007.207.000		G 03233 (H+S)	082.000.039.106.000
Pin contact straight	122.348.009.207.000		RG 59	082.000.039.109.000
Socket contact straight	122.348.004.207.000	75	RG 179 / RG 187	082.000.039.102.000
Socket contact straight	122.348.008.207.000		G 03233 (H+S)	082.000.039.106.000
Socket contact straight	122.348.010.207.000		RG 59	082.000.039.109.000
Crimping tool for shielding sleeve	080.000.039.000.000			

¹⁾ Special lines on request

Module 2 Positions for Compressed Air Valves, Tube Diameter: max. 4 mm

Technical data

Mechanical data

Valid operating pressure max.	20 bar
Total mating force (average)	
– not shut off	27 N/module
– one side shut off	28 N/module
– both side shut off	29 N/module
Total demating force (average)	
– not shut off	12.6 N/module
– one side shut off	12.6 N/module
– both side shut off	9.2 N/module
Operating temperature	–40° C to +125° C
Mating cycles	min. 5,000 (with regular maintenance intervals higher mating cycles are possible)



Materials

Insulator	Thermoplast, polyester fibre-glass reinforced acc. UL-94
Valve body	Cu alloy, blank
Composition	NBR

Technical details

– Due to the function, the contacts are pre-stressed in the mated state. The frame must maintain this pre-stress with a holding device.

Flow rate diagram

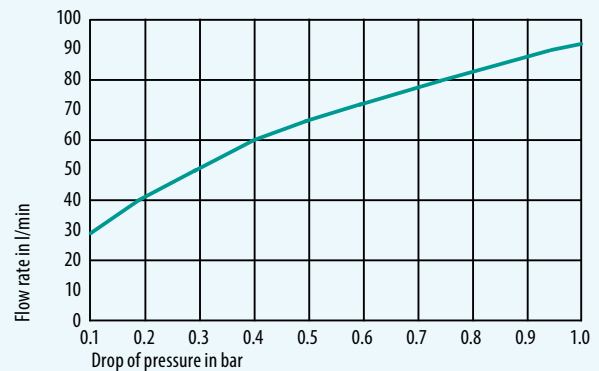

Module 2 positions for compressed air valves, tube diameter: max. 4 mm

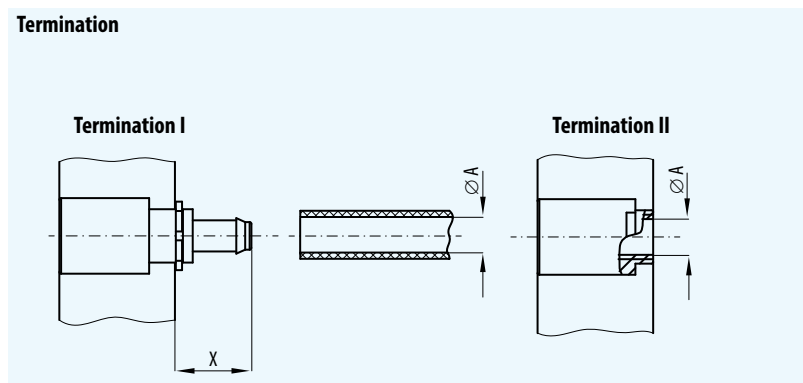
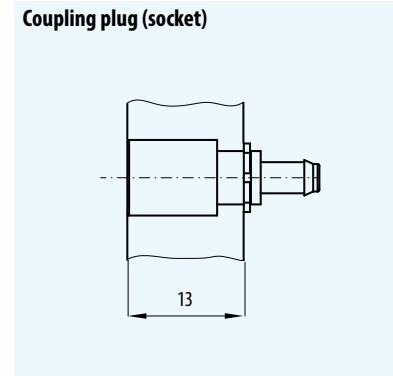
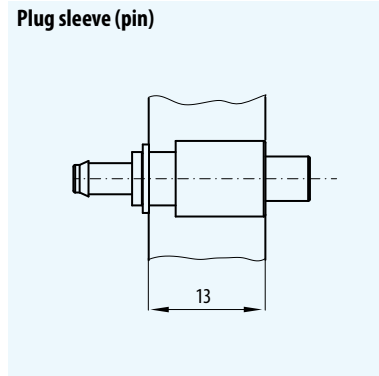
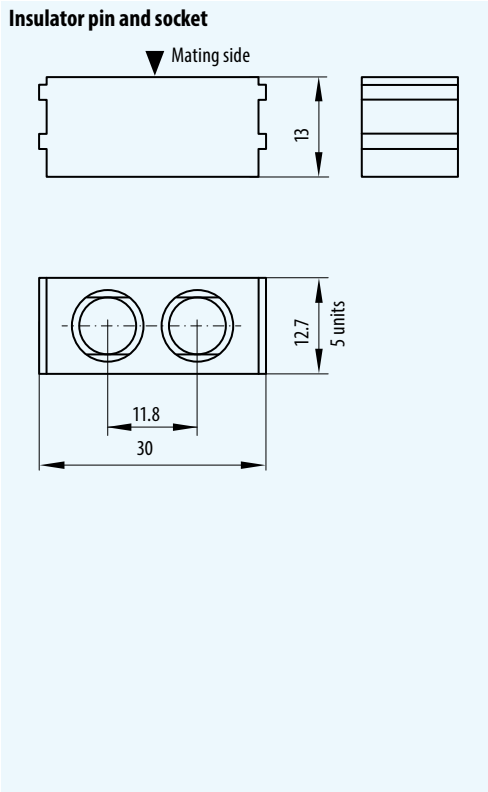

Modules

	Part number	Dimension A	Dimension X	Termination		
		mm	mm	I	II	
Insulator	611.141.102.923.000					
Plug sleeve (not shut off)	196.023.001.300.000	3	8.5	x		
Plug sleeve (not shut off)	196.024.001.300.000	4	10.5	x		
Plug sleeve (not shut off)	196.025.001.300.000	M5	–		x	
Coupling (not shut off)	196.023.003.300.000	3	8.5	x		
Coupling (not shut off)	196.024.003.300.000	4	10.5	x		
Coupling (not shut off)	196.025.003.300.000	M5	–		x	
Plug sleeve (shut off) ¹⁾²⁾	196.025.014.300.000	M5	–		x	
Coupling (shut off)	196.023.002.300.000	3	8.5	x		
Coupling (shut off)	196.024.002.300.000	4	10.5	x		
Coupling (shut off) ²⁾	196.025.012.300.000	M5			x	

¹⁾ Can only be plugged into coupling plug 196.025.012.300.000

²⁾ Sealing material: FKM

Module 1/2 Positions for Compressed Air Valves Tube Diameter: max. 6 mm

Technical data

Mechanical data

Valid operating pressure max.	12 bar
1/2 positions	
Total mating force (average)	
– not shut off	5.4 N/valve
– not shut off	6.4 N/valve
Total demating force (average) ¹⁾	
– not shut off	3.4 N/valve
– not shut off	3.4 N/valve
Operating temperature	–40° C to +125° C
Mating cycles	min. 5,000

Materials

Insulator	Thermoplast, polyester fibre-glass reinforced acc. UL-94
Compressed air valves	Cu alloy, blank
Sealing	NBR

Technical details

- Two-sided shut-off version on request.
- Due to the function, the contacts are pre-stressed in the mated state. The frame must maintain this pre-stress with a holding device.



Flow rate diagram

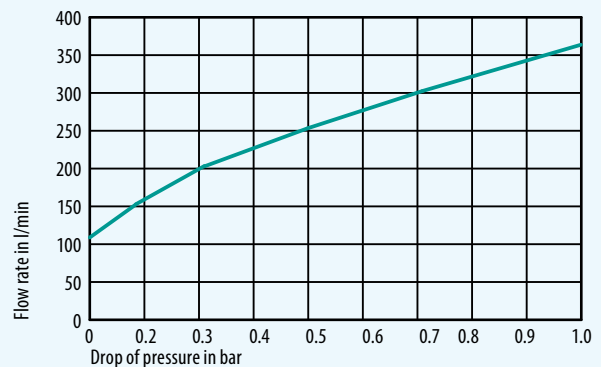

Module 1/2 positions for compressed air valves, tube diameter: max. 6 mm

Insulator socket (2 positions)

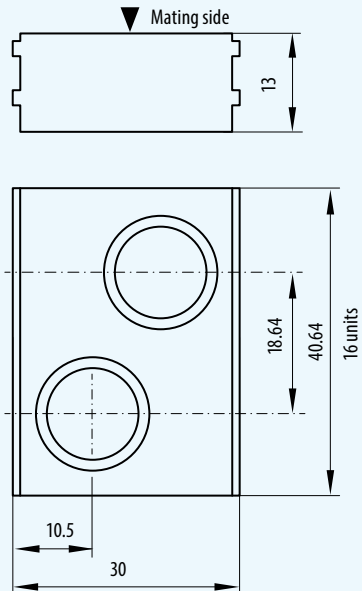

Insulator pin

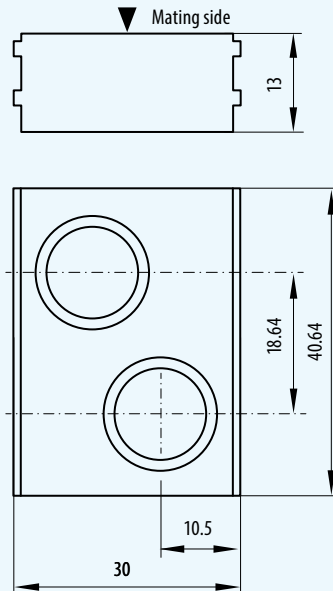

Insulator pin and socket (1 position)

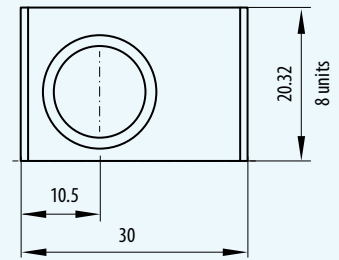

Coupling plug socket

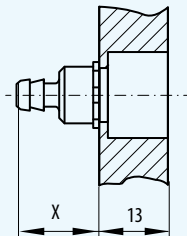

Plug sleeve pin

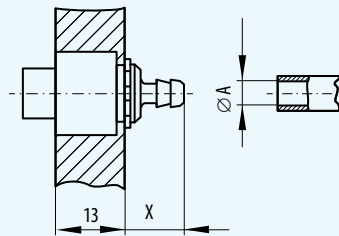

Modules

	Part number	Dimension A	Dimension X	
		mm	mm	
Insulator socket 2 positions	610.140.102.923.000			
Insulator pin 2 positions	611.140.102.923.000			
Insulator	611.142.101.923.000			
Plug sleeve (not shut off)	196.001.001.300.000	4	15.0	
Plug sleeve (not shut off)	196.002.001.300.000	6	17.5	
Coupling plug (not shut off)	196.001.003.300.000	4	15.0	
Coupling plug (not shut off)	196.002.003.300.000	6	17.5	
Coupling plug (shut off)	196.001.002.300.000	4	15.0	
Coupling plug (shut off)	196.002.002.300.000	6	17.5	

Module for Fluid Coupling Plug, Both Sides Shut Off, Low-Leakage Design Suitable for conducting air, water and other fluids

Technical data

Mechanical data

Valid operating pressure max.	6 bar
Tube termination	Tube termination M5 internal screw thread, commercially available threaded joints
Total mating force (average)	48 N/module
Total demating force (average)	4.6 N/module
Operating temperature	-40°C to +125°C
Mating cycles	min. 15,000

Materials

Insulator	Thermoplast, Polyester fibre-glass reinforced acc. UL-94
Compressed air valves	Brass, nickel-plated or stainless steel, FKM
Sealing	FKM



Technical details

- Due to the function, the contacts are pre-stressed in the mated state. The frame must maintain this pre-stress with a holding device.
- The use of combustible or explosive liquids or gases is not permitted.

Flow rate diagram air

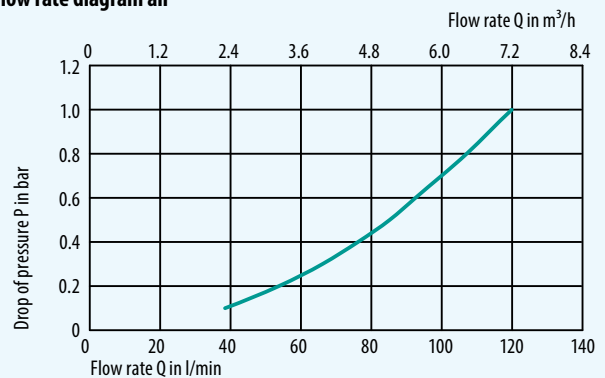

Flow rate diagram water

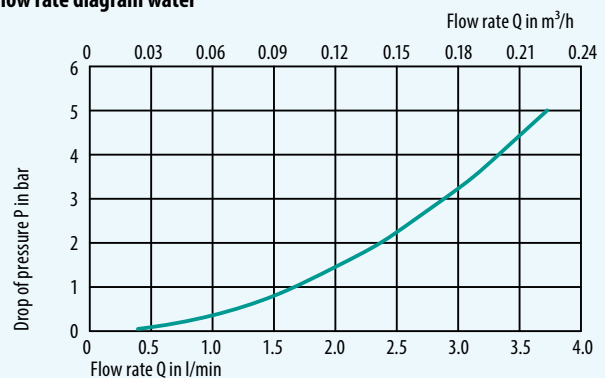

Module for fluid coupling plug, both sides shut off, low-leakage design
Suitable for conducting air, water and other fluids

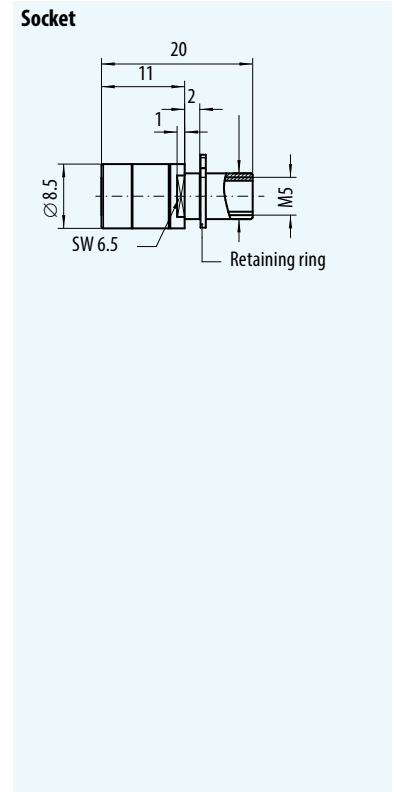
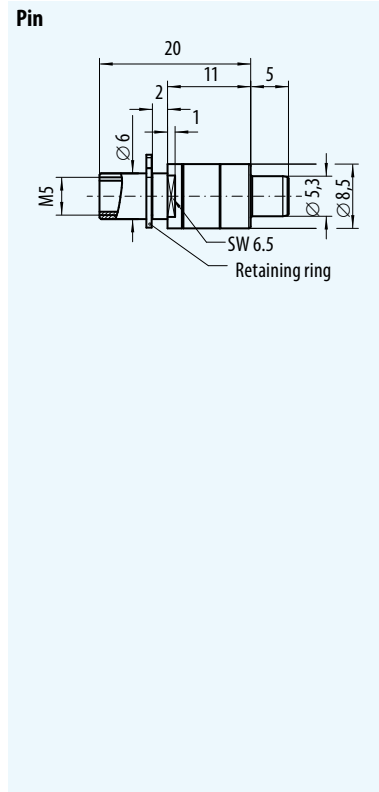
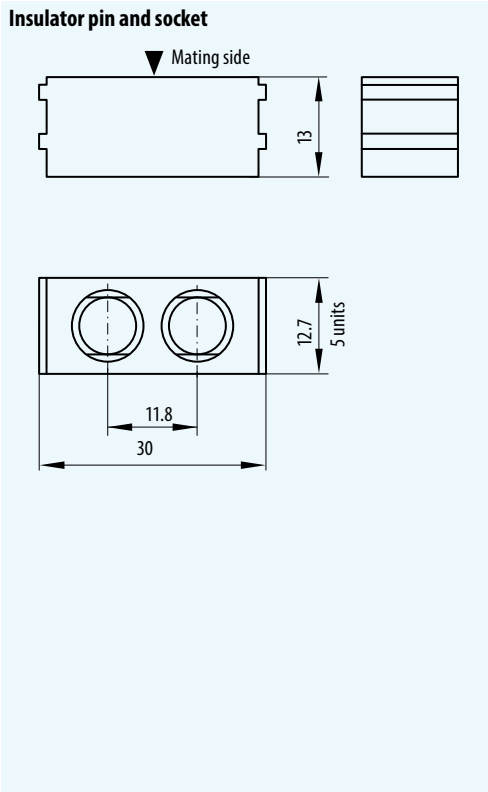

Modules

	Part number	Version
Insulator	611.141.102.923.000	
Sealing nipple (pin piece)	196.025.015.902.001	stainless steel (standard)
Sealing coupling plug (socket piece)	196.025.016.902.001	stainless steel (standard)
Sealing nipple (pin piece)	196.025.015.304.000	nickel-plated brass
Sealing coupling plug (socket piece)	196.025.016.304.000	nickel-plated brass

Accessories for fluid coupling plug module

Technical data

Mechanical data

Valid operating pressure (static)	0.95 to 14 bar
Operating temperature	-10°C to +80°C
Threaded connection	M5

Technical details

- Tightening torque: 1.5 Nm

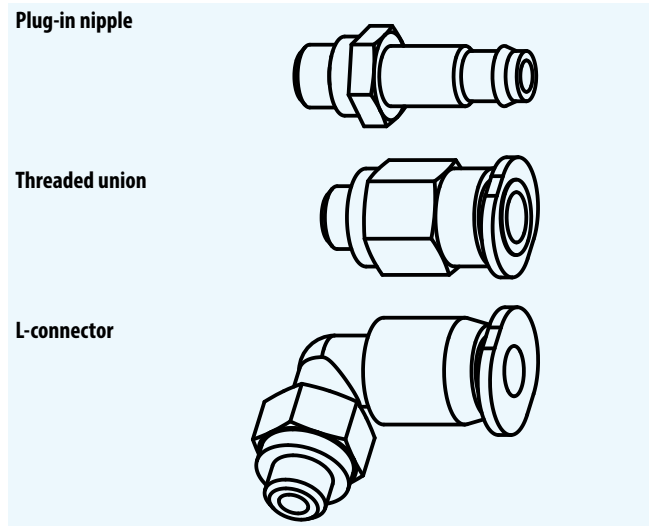

	Dimension A mm	Dimension B mm	Part number
Plug-in nipple	2		945.000.001.000.123
	3		945.000.001.000.136
	4		945.000.001.000.137
Threaded union		3	945.000.001.000.138
		4	945.000.001.000.139
		6	945.000.001.000.140
L-connector		3	945.000.001.000.141
		4	945.000.001.000.142
		6	945.000.001.000.143

Accessories for fluid coupling plug module

Termination dimensions for fluid coupling plug accessory

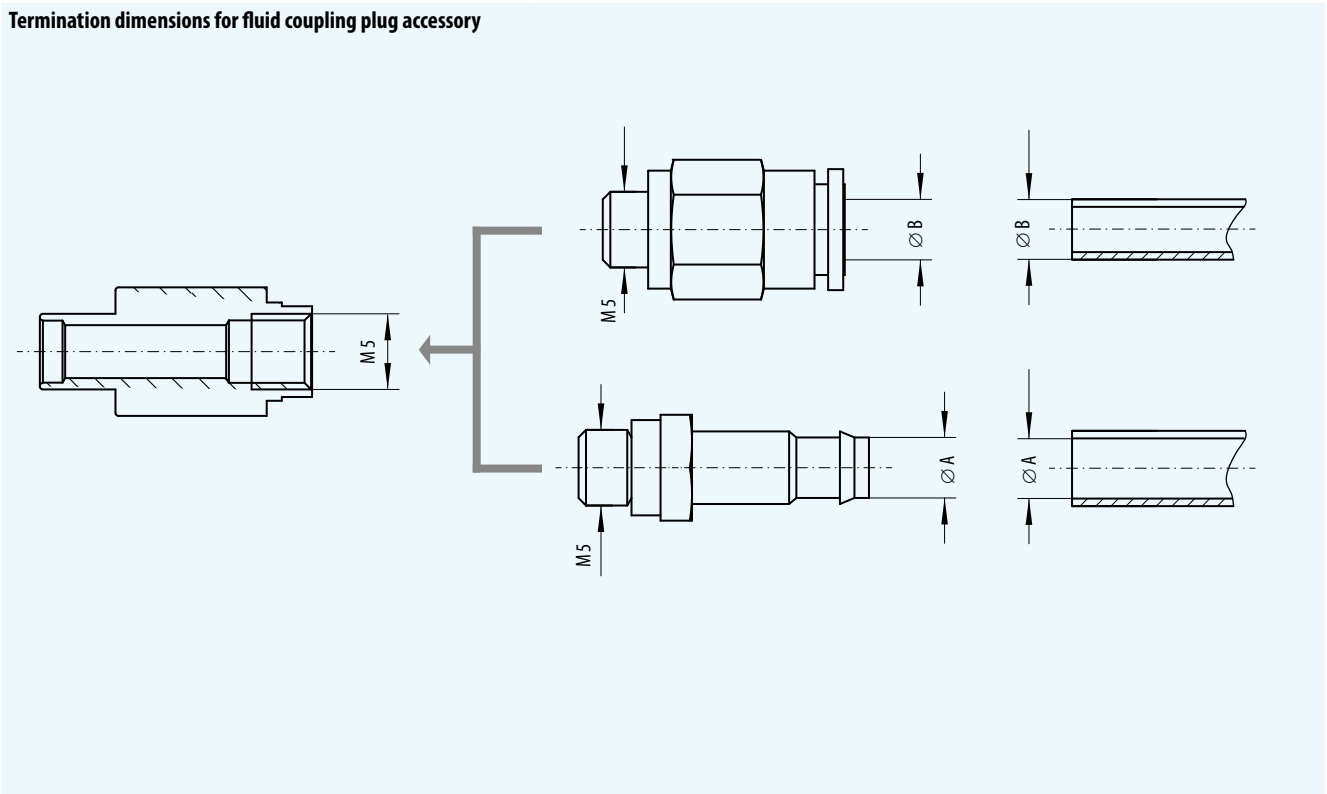

Assembly of the air coupling plug

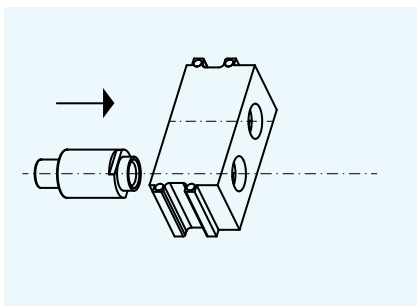

1. Insert air coupling plug into the insulator.

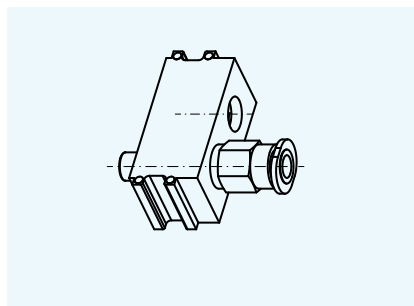

2. Screw threaded joint into the air coupling plug.
Tightening torque: 1.5 Nm.

Module 2 Positions for Fibre-Optic Contacts for Plastic Fibre

Technical data

Mechanical data

POF (Polymer Optical Fibre)	1 mm
Outer diameter	2.2 mm resp. 2.3 mm
Fibre fastening	Clamping
Insertion loss	
– Typical	1.5 dB at 670 nm
– During life-time	< 2.0 dB at 670 nm
Total mating force (average)	16.0 N
Operating temperature	
– Standard fibre	–40° C to +85° C
– High temperature fibre	–40° C to +115° C
Mating cycles	min. 100,000

Materials

Insulator	Thermoplast, polyester fibre-glass reinforced acc. UL-94
Fibre-optic contact	Cu alloy
Type of fibre	Plastic fibre 980/1000 (POF) or 980/1550



Technical details

- Due to the function, the contacts are pre-stressed in the mated state. The frame must maintain this pre-stress with a holding device.
- Please request the assembly instructions.

Module 2 positions for fibre-optic contacts for plastic fibre

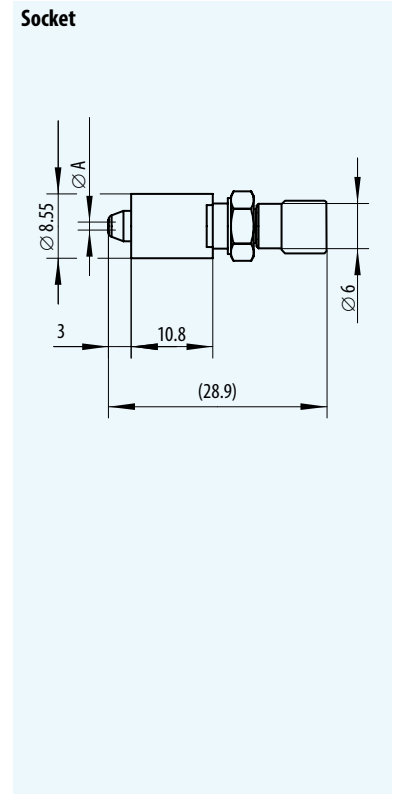
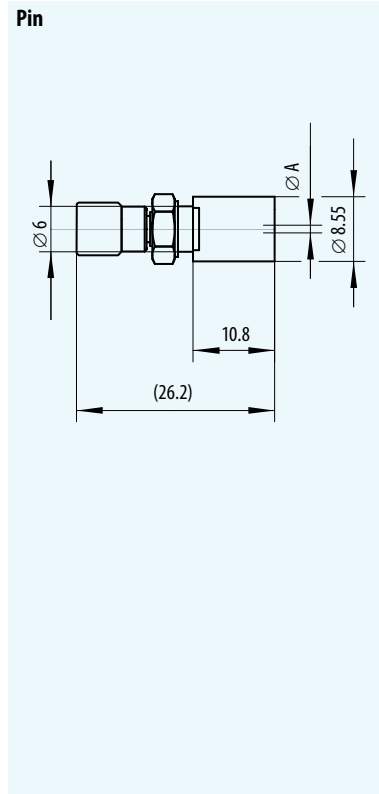
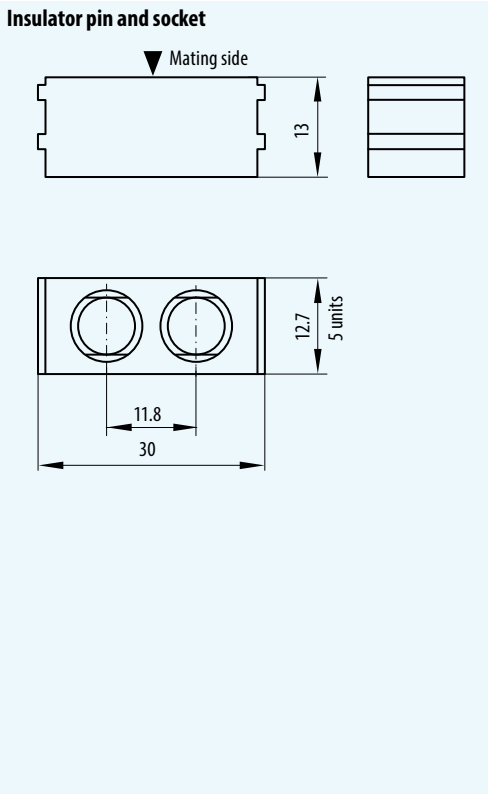

Modules

	Part number	Dim. A
		mm
Insulator	611.141.102.923.000	
Socket contact 980/1000 µm	196.501.001.901.000	1.05
Pin contact 980/1000 µm	196.501.002.901.000	1.05
Socket contact 980/1550 µm (MOST standard)	196.502.001.901.000	1.60
Pin contact 980/1550 µm (MOST standard)	196.502.002.901.000	1.60
Tool for cable-stripping	598.501.001.000.000	
Wrench/spanner 4.5 mm	598.501.002.000.000	
Wrench/box spanner 8 mm	598.501.003.000.000	
Polish-device for socket	598.501.004.000.000	
Spare blades	598.501.006.000.000	
Polish-device for pin	598.501.007.000.000	
Lapp foils, 12 µm, 5 µm	598.501.010.000.000	

Module 5 Positions for Fibre-Optic Contacts for Plastic Fibre¹⁾

Technical data

Mechanical data

POF (Polymer Optical Fibre)	1 mm
Outer diameter	2.2 mm resp. 2.3 mm
Fibre fastening	Crimp
Insertion loss	1.5 dB at 670 nm
– Typical	< 2.0 dB at 670 nm
– During life-time	
Total mating force (average)	< 17.5 N
Operating temperature	
– Standard fibre	–40° C to +85° C
– High temperature fibre	–40° C to +115° C
Mating cycles	min. 40,000

Materials

Insulator	Thermoplast, polyester fibre-glass reinforced acc. UL-94
Fibre-optic contact	Cu alloy
Type of fibre	Plastic fibre 980/1000 (POF)

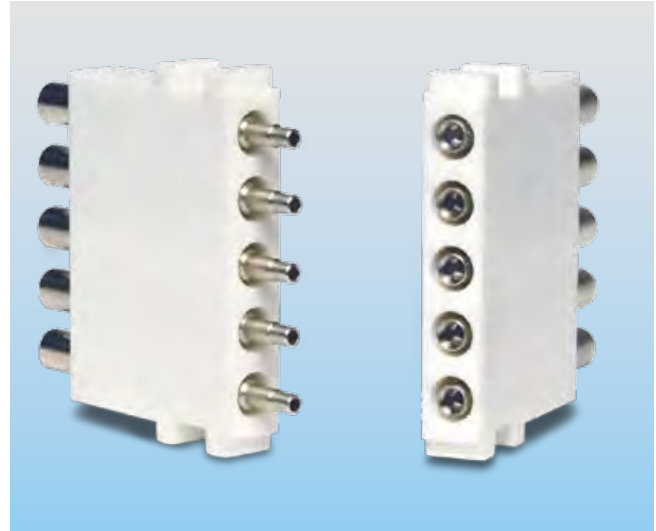

Technical details

- Due to the function, the contacts are pre-stressed in the mated state. The frame must maintain this pre-stress with a holding device.
- Please request the assembly instructions.

¹⁾ Fibre-optic contacts for fibre-glass on request!



Removal tool

Removal from the front is possible, no cutting off required.

Part number 087.611.001.002.000

Module 5 positions for fibre-optic contacts for plastic fibre

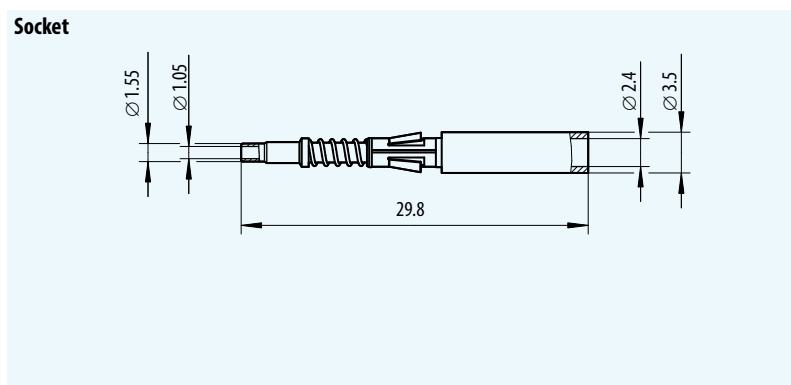
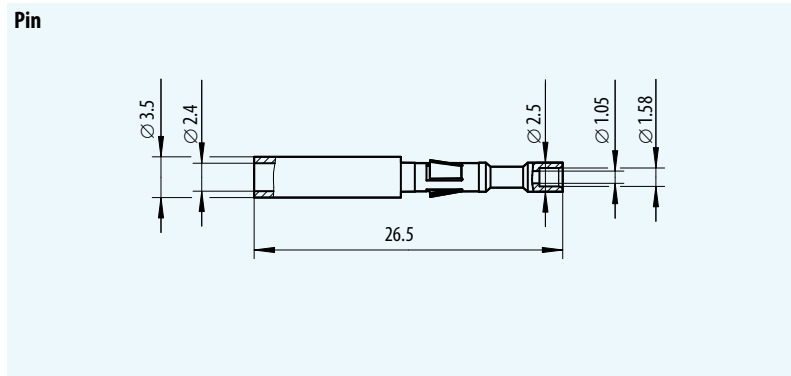
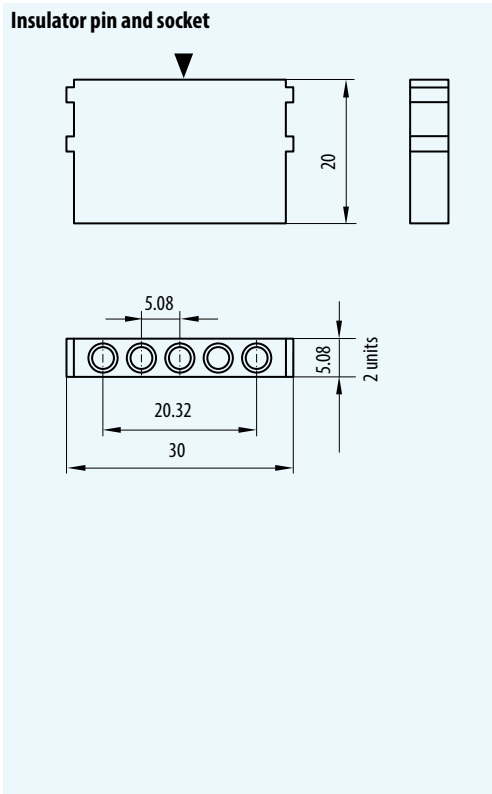

Modules

	Part number
Insulator	611.163.105.923.000
Socket contact 980/ 1000 µm	196.503.001.901.000
Pin contact 980/1,000 µm	196.503.002.901.000
Set (strip- and crimpwrench)	080.000.048.000.000
Tool for cable stripping	080.000.048.100.000
Crimp tool	080.000.048.200.000

Module 3 Positions for Fibre-Optic Contacts for Fibre-Glass

Technical data

Mechanical data

Fibre-glass	Single mode – 9/125 µm Multi mode – 50/125 µm Multi mode – 62.5/125 µm
Fibre fastening	Optical fibre glued ¹⁾ Surface polished ¹⁾ Sheath crimped
Insertion loss typical	<1.0 dB
Total mating force (average)	≤36.0 N
Assembly holding force	10.0 to 12.0 N/contact
Operating temperature	–40°C to +85°C
Mating cycles	min. 100,000

Materials

Insulator	Thermoplast, polyester fibre-glass reinforced acc. UL-94
Ferrule holder	Nickel silver
Ferrule	Ceramic
Spring	CrNi steel



Technical details

- Due to the function, the contacts are pre-stressed in the mated state. The frame must maintain this pre-stress with a holding device.
- Please request the assembly instructions.

¹ Fibre assembly (gluing and polishing) on request!



Removal tool I (straight)

Removal of the already assembled contact (including cable). Part number 087.170.136.000.000



Removal tool II

Removal of contact that has not been assembled yet (without cable – may have to be cut off). Part number 087.611.001.001.000

Module 3 positions for fibre-optic contacts for fibre-glass

Insulator socket

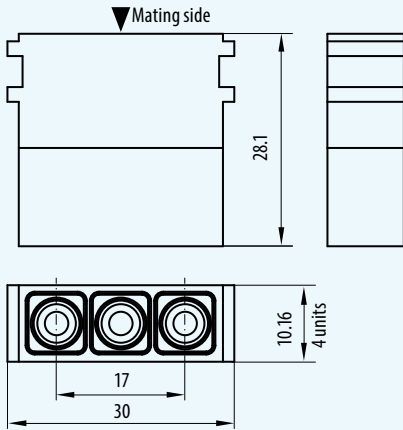

Insulator pin

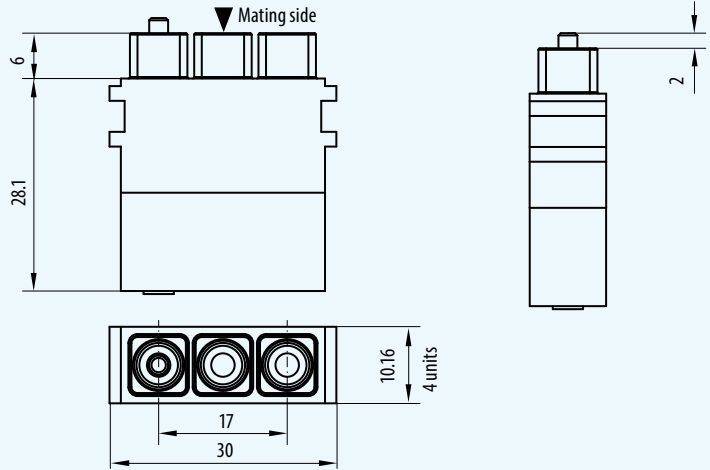

Socket

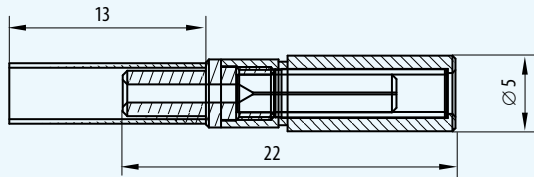

Pin

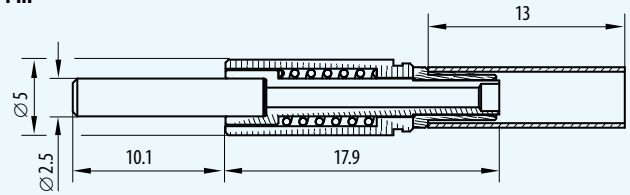

	Part number	Part number crimp die	LWL fibre	
Insulator pin piece	611.162.103.923.000	082.000.039.102.000	50 / 125 µm; 62.5 / 125 µm 9 / 125 µm	
Insulator socket piece	610.162.103.923.000			
Pin contact	196.603.002.901.000			
Pin contact	196.603.004.901.000			
Socket contact	196.603.001.901.000			
Socket contact	196.603.003.901.000			
Crimping tool for shielding	080.000.039.000.000			

Multi-Position Module (2 to 10 Positions), Shielded Implementation, Size 0 (e.g., for Use in Bus Systems)

Technical data

The inserts listed here for shielded implementations are optimally suitable for all common bus systems with transfer rates up to 10 MHz. For example, Profibus, USB1.1, RS485, Flexray, CAN-Bus and RS233.

Selected inserts are suitable and qualified for data rates up to 480 MBit/s. For example, Fast-Ethernet, USB2.0, IEEE 1394.

Mating cycles: min. 5,000.



Assembly instruction (pin piece)

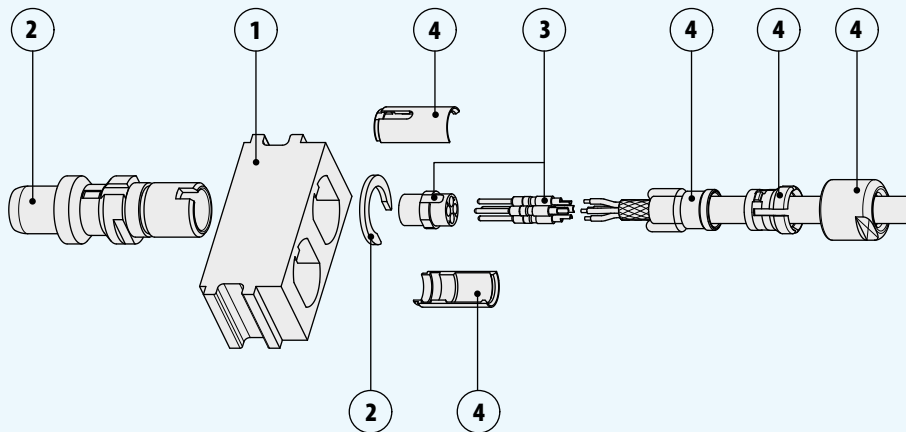

Assembly set

Picture number	Basis parts	Part number
1	Insulator	611.148.102.923.000
2	Socket housing cpl.	653.001.001.304.000
2	Pin housing cpl.	653.001.002.304.000
	Sealing plug	021.341.182.300.000
3	Insert cpl.	see next page
4	Assembly set	see table

Cable Ø mm	Part number
1.5–2.0	653.001.001.304.020
2.0–2.5	653.001.001.304.025
2.5–3.0	653.001.001.304.030
3.0–3.5	653.001.001.304.035
3.5–4.0	653.001.001.304.040
4.0–4.5	653.001.001.304.045
4.5–5.0	653.001.001.304.050

Multi-position module (2 to 10 positions), shielded implementation, size 0 (e.g., for use in bus systems)

Insulator pin and socket

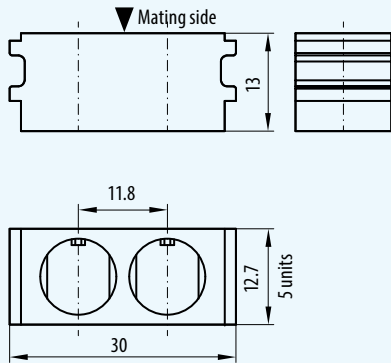

Pin

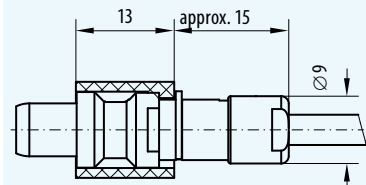

Socket

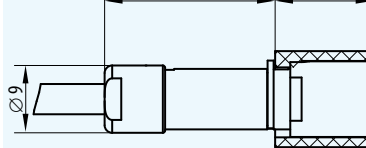

Stripping length

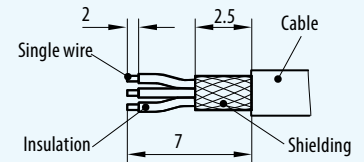

Contact arrangements

Pin

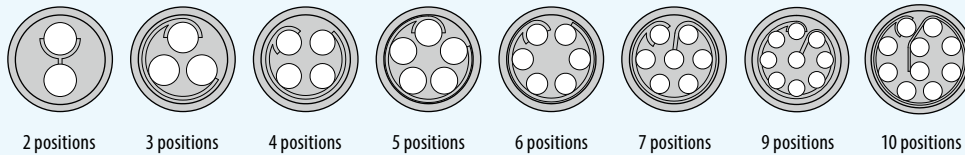

Socket

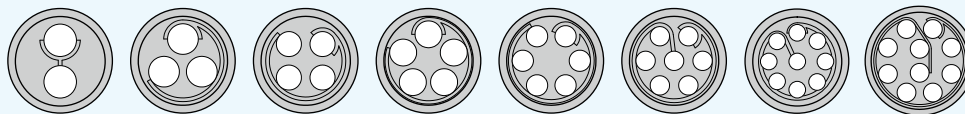

Number of pos.	Contact diameter mm	Termination cross-section AWG	Rated voltage ¹⁾ V	Rated impulse voltage ¹⁾ kV	Pollution degree ¹⁾ acc. VDE 110	Nominal voltage ²⁾ V AC	Version	Category ³⁾	Insert cpl. ⁴⁾ part number	Mating force N	Demating force N
2	0.9	22	10	2.0	3	500	Pin		700.849.724.002.200	20	15
			32	2.0	2		Socket		700.749.724.002.200		
3	0.9	22	32	1.5	2	400	Pin		700.849.724.003.200	20	15
							Socket		700.749.724.003.200		
4	0.7	26	32	1.5	2	300	Pin	CAT-5	700.848.724.004.200	22	17
							Socket	CAT-5	700.748.724.004.200		
4	0.7	22	32	1.5	2	300	Pin	USB 2.0	700.848.724.404.221	22	17
							Socket	USB 2.0	700.748.724.404.200		
5	0.7	26	32	1.5	2	366	Pin		700.848.724.005.200	22	17
							Socket		700.748.724.005.200		
6	0.5	28	32	1.5	2	300	Pin		700.841.724.006.200	23.5	18
							Socket		700.741.724.006.200		
7	0.5	28	32	1.5	2	300	Pin		700.841.724.007.200	23.5	18
							Socket		700.741.724.007.200		
9	0.5	28	10	1.2	2	200	Pin		700.841.724.009.200	23.5	18
							Socket		700.741.724.009.200		
10	0.5	28	10	1.2	2	200	Pin		700.841.724.010.221	23.5	18
							Socket		700.741.724.010.221		

¹ Acc. to DIN EN 60664.1 : 2007 (VDE 0110 Teil 1), see page 118

² Acc. to MIL SAE AS13441/IEC 60512-2

³ Classification to IEC 11801 : 2010

⁴ Insert in crimp model on request.

Multi-Position Module (2 to 14 Positions), Shielded Implementation Size 1 (e.g., for Use in Bus Systems)

Technical data

The inserts listed here for shielded implementations are optimally suitable for all common bus systems with transfer rates up to 10 MHz. For example, Profibus, RS485, Flexray, CAN-Bus and RS233.

Selected inserts are suitable and qualified for data rates up to 1 GBit/s. For example, Gigabit-Ethernet, Fast-Ethernet, IEEE 1394, Firewire S400, Firewire S800.

Mating cycles: min. 5,000.



Assembly instruction (pin piece)

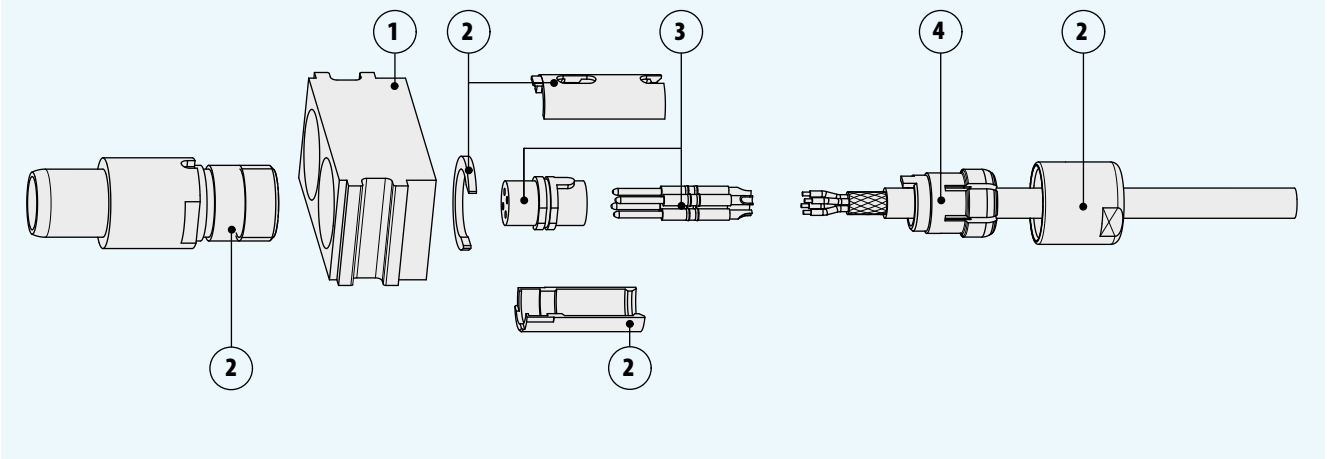

Cable collets

Picture number	Basis parts	Part number
1	Insulator	611.167.102.923.000
2	Socket housing cpl.	653.002.001.304.000
2	Pin housing cpl.	653.002.002.304.000
	Sealing plug	021.341.182.300.000
3	Insert cpl.	see next page
4	Cable collets	see table

Cable Ø mm	Part number
1.5 – 2.1	751.020.188.304.022
2.0 – 3.2	751.020.188.304.032
3.0 – 4.2	751.020.188.304.042
4.0 – 5.2	751.020.188.304.052
5.0 – 6.2	751.020.188.304.062
6.0 – 7.2	751.020.188.304.072
7.0 – 7.7	751.020.188.304.077

Multi-position module (2 to 14 positions), shielded implementation, size 1 (e.g., for use in bus systems)

Insulator pin and socket

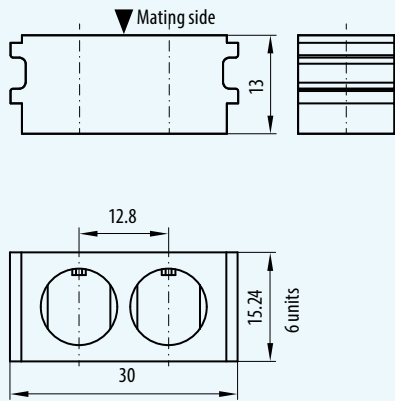

Pin

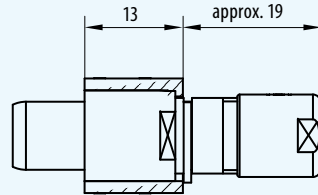

Socket

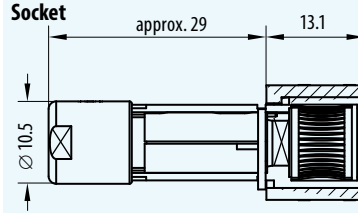

Stripping length

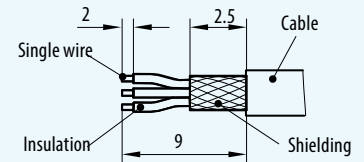

Contact arrangements

Pin

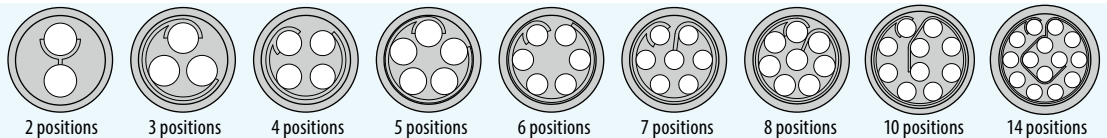

Socket

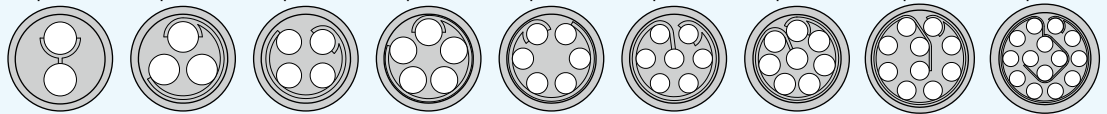

Number of pos.	Contact diameter	Termination cross-section	Rated voltage ¹⁾	Rated impulse voltage ¹⁾	Pollution degree ¹⁾ acc. VDE 110	Nominal voltage ²⁾	Version	Category ³⁾	Insert cpl. ⁴⁾ part number	Mating force	Demating force
	mm	AWG									
2	1.3	20	32	2	3	550	Pin Socket		701.844.724.002.200	8.5	7.5
			80						701.744.724.002.200		
3	1.3	20	16	2	3	500	Pin Socket		701.844.724.003.200	8.5	7.5
			40						701.744.724.003.200		
4	0.9	22	10	2	3	500	Pin Socket	CAT-5 CAT-5	701.849.724.004.200	10.5	9.0
			32						701.749.724.004.200		
5	0.9	22	32	1.5	2	450	Pin Socket		701.849.724.005.200	10.5	9.0
									701.749.724.005.200		
6	0.7	22	32	1.5	2	400	Pin Socket		701.848.724.406.200	13.0	10.0
									701.748.724.406.200		
7	0.7	22	32	1.5	2	400	Pin Socket		701.848.724.407.200	13.0	10.0
									701.748.724.407.200		
8	0.7	22	32	1.5	2	333	Pin Socket		701.848.724.408.200	13.0	10.0
									701.748.724.408.200		
8	0.7	26	32	1.5	2	333	Pin Socket	CAT-5 CAT-5	701.841.724.408.D00	13.0	10.0
									701.741.724.408.D00		
10	0.5	28	25	1.5	2	333	Pin Socket		701.841.724.010.400	15.0	12.0
									701.741.724.010.200		
14	0.5	28	25	1.5	2	300	Pin Socket		701.841.724.014.400	15.0	12.0
									701.741.724.014.200		

Insert with ODU SPRINGTAC® (mating cycles: 60,000):

4	0.76	22	25	2	3	450	Pin Socket	CAT-5 CAT-5	701.842.724.004.700	7.5	7.0
			63						701.742.724.004.700		
5	0.76	22	25	1.5	3	400	Pin Socket		701.842.724.005.700	8.5	8.0
			63						701.742.724.005.700		

¹ Acc. to DIN EN 60664.1 : 2007 (VDE 0110 Teil 1), see page 118.

² Acc. to MIL SAE AS13441/IEC 60512-2

³ Classification to IEC 11801 : 2010

⁴ Insert in crimp model on request.

Multi-Position Module (4 and 8 Positions), Shielded Implementation Size 2 (e.g., for Use in Bus Systems)

Technical data

The inserts listed here for shielded implementations are optimally suitable for all common bus systems with transfer rates up to 10 MHz. For example, Profibus, RS485, Flexray, CAN-Bus and RS233.

Selected inserts are suitable and qualified for data rates up to 10 GBit/s. For example, 10 Gigabit-Ethernet, Gigabit-Ethernet, Fast-Ethernet, IEEE 1394, Firewire S400, Firewire S800.

Mating cycles: min. 5,000.



Assembly instruction (pin piece)

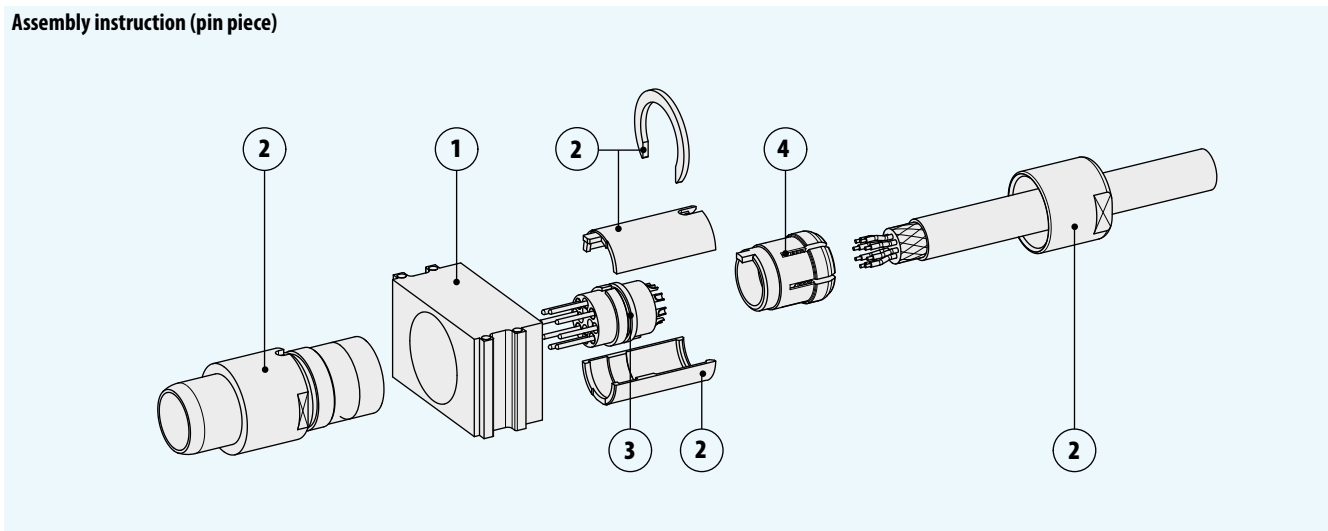

Cable collets

Picture number	Basis parts	Part number
1	Insulator	611.170.101.923.000
2	Socket housing cpl.	653.003.001.304.000
2	Pin housing cpl.	653.003.002.304.000
3	Insert cpl.	see next page
4	Cable collets	see table

Cable \varnothing mm	Part number
2.0 – 3.2	752.020.188.304.032
3.0 – 4.2	752.020.188.304.042
4.0 – 5.2	752.020.188.304.052
5.0 – 6.2	752.020.188.304.062
6.0 – 7.2	752.020.188.304.072
7.0 – 8.2	752.020.188.304.082
8.0 – 9.2	752.020.188.304.092
9.0 – 9.9	752.020.188.304.099

Multi-position module (4 and 8 positions), shielded implementation, size 2 (e.g., for use in bus systems)

Insulator pin and socket

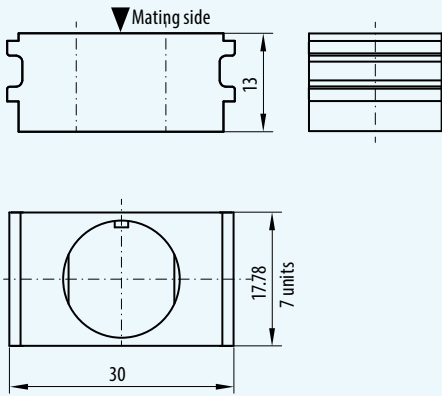

Pin

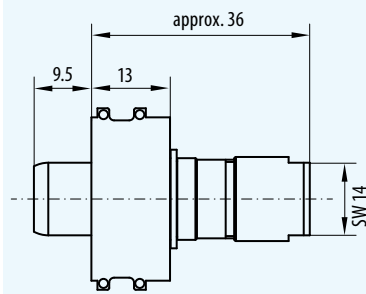

Socket

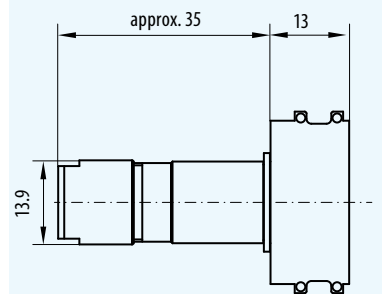

Contact arrangements

Pin

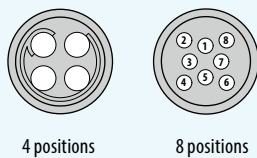

4 positions

8 positions

Socket

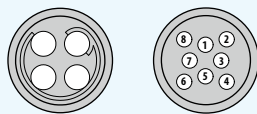

Stripping length

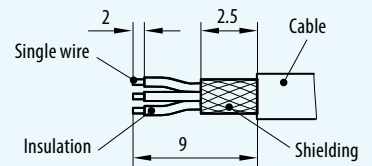

Number of pos.	Contact diameter mm	Termination cross-section AWG	Rated voltage ¹⁾ V	Rated impulse voltage ¹⁾ kV	Pollution degree ¹⁾ acc. VDE 110	Nominal voltage ²⁾ V AC	Version	Category ³⁾	Insert cpl. part number	Mating force N	Demating force N
8	0.9	22	20	2	3	500	Stift Buchse	CAT-6 _A	702.849.724.008.D00	14.7	12.6
			50		2				702.749.724.008.D00		
4	1.3	20	40	2.5	3	650	Stift Buchse	CAT-6 _A	702.844.724.004.200	8.5	8.0
			160		2				702.744.724.004.200		
Insert with ODU SPRINGTAC® (mating cycles: 60,000)											
8	0.76	22	16	2	3	550	Stift Buchse	CAT-5	702.842.724.008.D00	11.5	10.5
			40		2				702.742.724.008.D00		

¹ Acc. to DIN EN 60664.1 : 2007 (VDE 0110 Teil 1), see page 118.

² Acc. to MIL SAE AS13441/IEC 60512-2

³ Classification to IEC 11801 : 2010

Multi-Position Module (10 to 30 Positions), Shielded Implementation Size 3 (e.g., for Use in Bus Systems)

Technical data

The inserts listed here for shielded implementations are optimally suitable for all common bus systems with transfer rates up to 10 MHz. For example, Profibus, RS485, Flexray, CAN-Bus and RS233.

Selected inserts are suitable and qualified for data rates up to 10 GBit/s. For example, 10 Gigabit-Ethernet, Gigabit-Ethernet, Fast-Ethernet, IEEE 1394, Firewire S400, Firewire S800.

Mating cycles: min. 5,000.



Assembly instruction (pin piece)

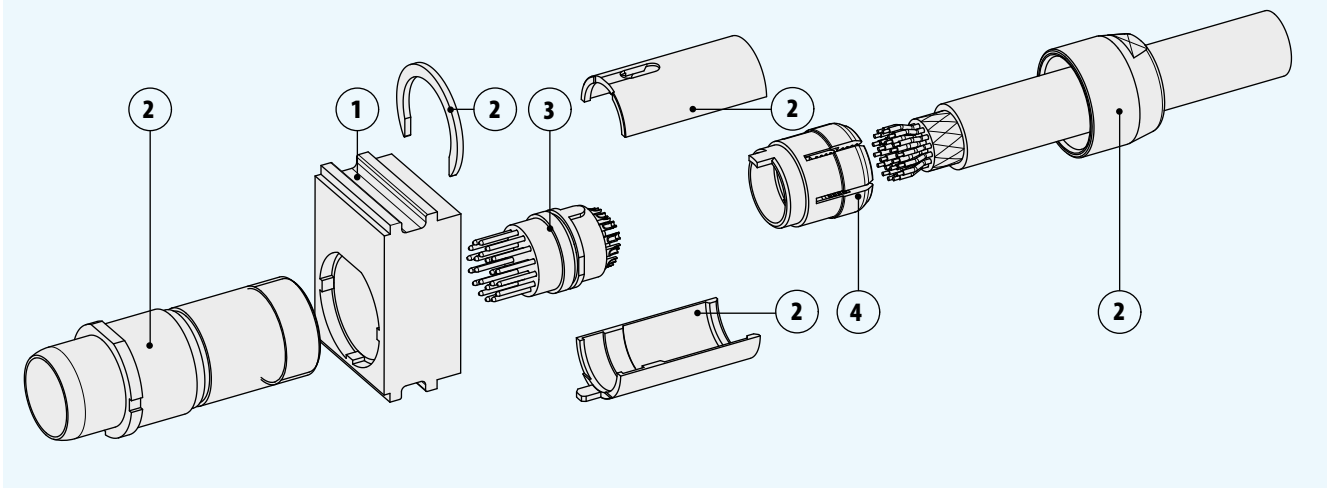

Picture number	Basis parts	Part number
1	Insulator	611.171.101.923.000
2	Socket housing cpl.	653.004.001.304.000
2	Pin housing cpl.	653.004.002.304.000
3	Insert cpl.	see next page
4	Cable collets	see table

Cable collets

Cable Ø mm	Part number
3.0 – 4.2	753.020.188.304.042
4.0 – 5.2	753.020.188.304.052
5.0 – 6.2	753.020.188.304.062
6.0 – 7.2	753.020.188.304.072
7.0 – 8.2	753.020.188.304.082
8.0 – 9.2	753.020.188.304.092
9.0 – 10.2	753.020.188.304.102

Multi-position module, shielded implementation, size 3 (e.g., for use in bus systems)

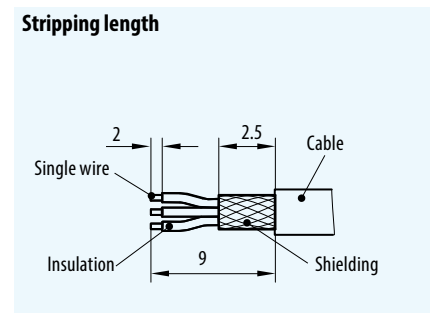
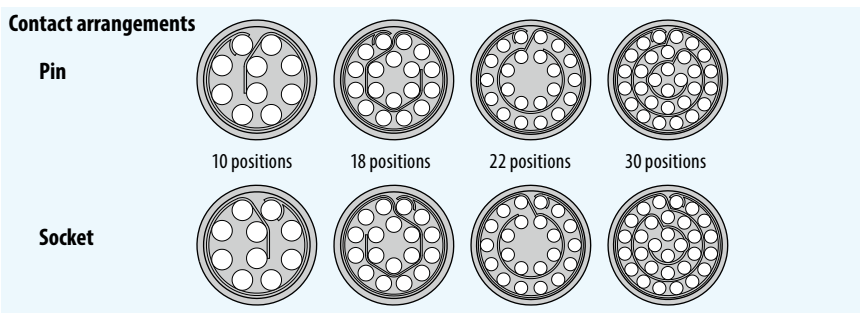
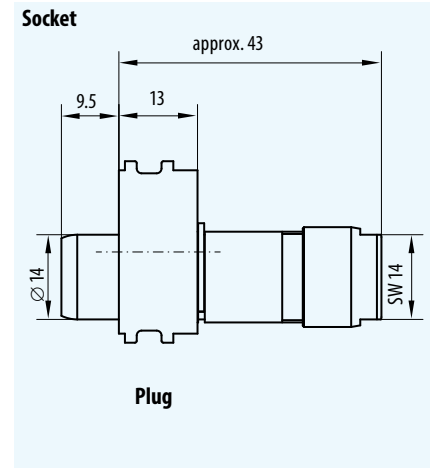
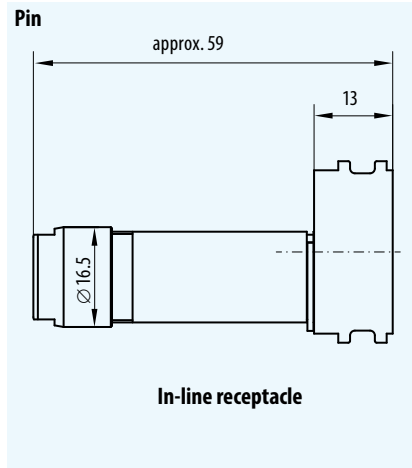
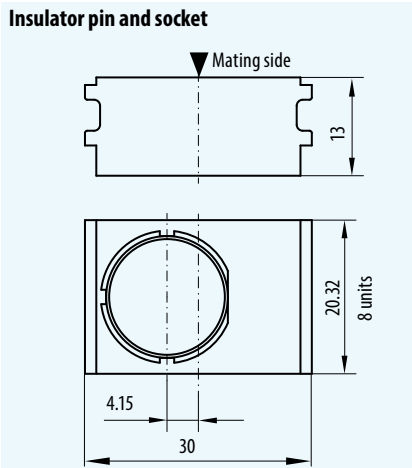

Number of pos.	Contact diameter	Termination cross-section	Rated voltage ¹⁾	Rated impulse voltage ¹⁾	Pollution degree ¹⁾ acc. VDE 110	Nominal voltage ²⁾	Version	Category ³⁾	Insert cpl. part number	Mating force	Demating force
	mm	AWG	V	kV		V AC					
10	1.3	20	20	2.0	3	450	Pin		703.844.720.010.200	21.6	19.1
			50	2.0	2		Socket		703.744.720.010.200		
18	0.9	22	10	2.0	3	450	Pin		703.849.720.018.200	22.3	20.8
			32	2.0	2		Socket		703.749.720.018.200		
22	0.7	26	32	1.5	2	366	Pin		703.848.720.022.200	21.7	19.7
			32	1.5	2		Socket		703.748.720.022.200		
30	0.7	26	32	1.5	2	300	Pin		703.848.720.030.200	28.1	24.5
			32	1.5	2		Socket		703.748.720.030.200		

¹ Acc. to DIN EN 60664.1 : 2007 (VDE 0110 Teil 1), see page 118.

³ Classification to IEC 11801 : 2010

² Acc. to MIL SAE AS13441/IEC 60512-2

Empty Modules

Modules

Technical data

Insulator

Thermoplast, polyester
fibre-glass reinforced
acc. UL-94

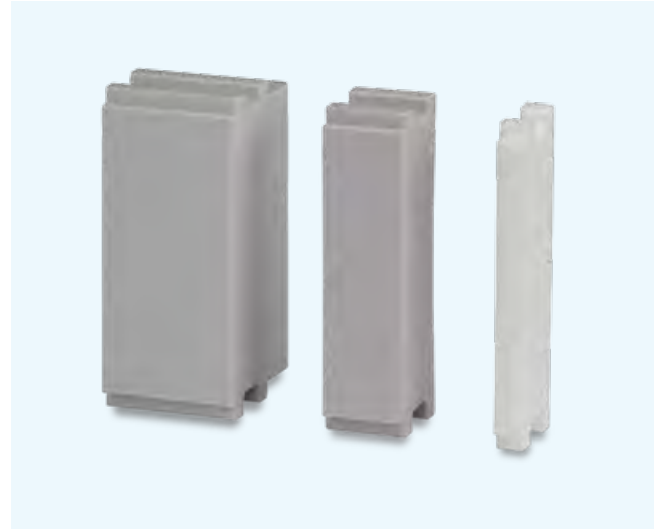

Units	Part number
1	611.122.113.923.000
3	611.130.113.923.000
5	611.128.113.923.000

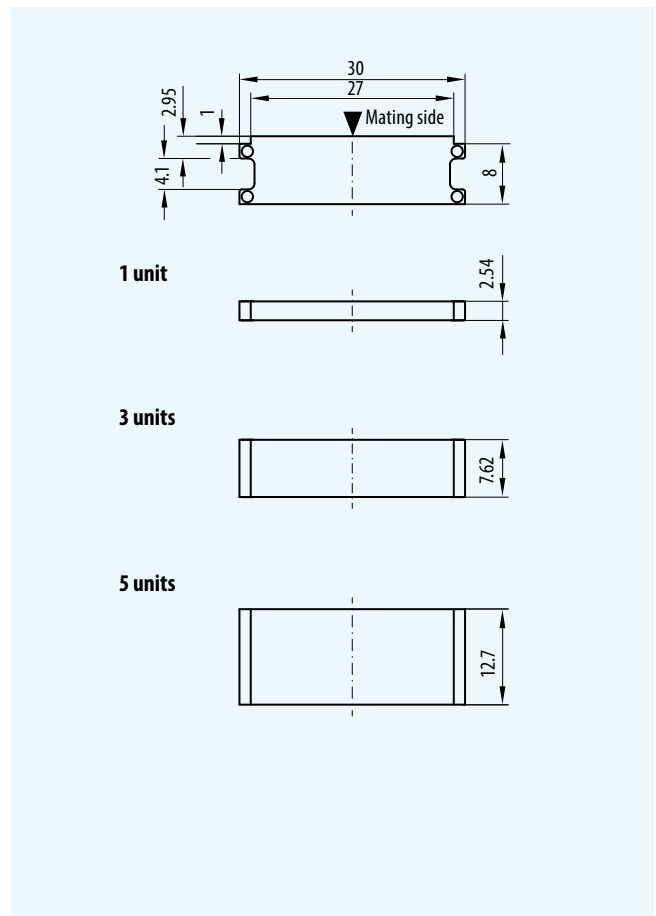

Coding Modules

Technical data

Insulator

Thermoplast, polyester
fibre-glass reinforced
acc. UL-94

Coding modules are arranged
between the insulators
in order to create a coded
connector.



Modules

Coding module – pin
1 unit (2.54 mm)
part number 611.161.101.923.000

Pin

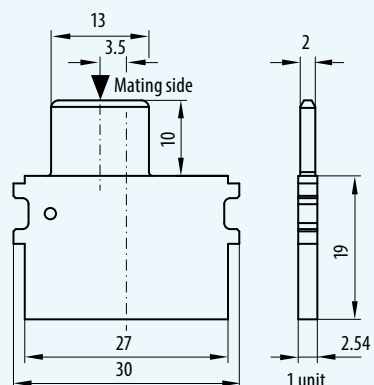

Coding module – socket
1 unit (2.54 mm)
part number 610.161.101.923.000

Socket

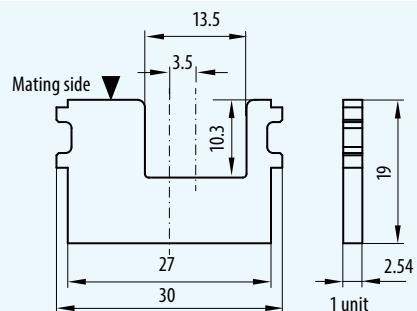

Pin Protection Modules

Technical data

Insulator

Thermoplast, polyester
fibre-glass reinforced
acc. UL-94

These modules are used to
protect the pins in connections
with small pin diameters.



Pin protection module – pin
1 unit (2.54 mm)
Part number 611.122.115.923.000

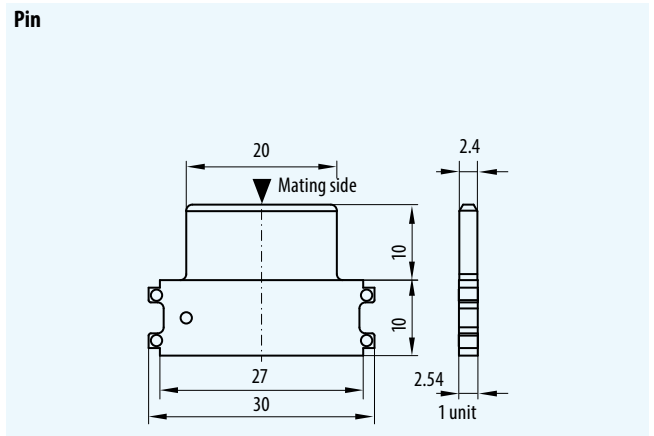

Pin protection module – socket
1 unit (2.54 mm)
Part number 610.122.115.923.000

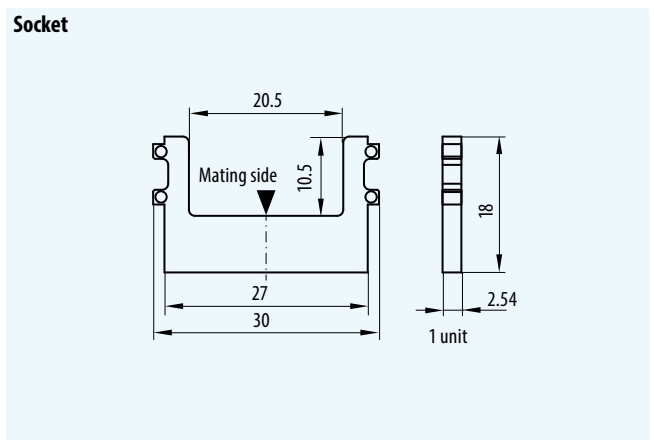

ODU-MAC in the Aluminium Frame

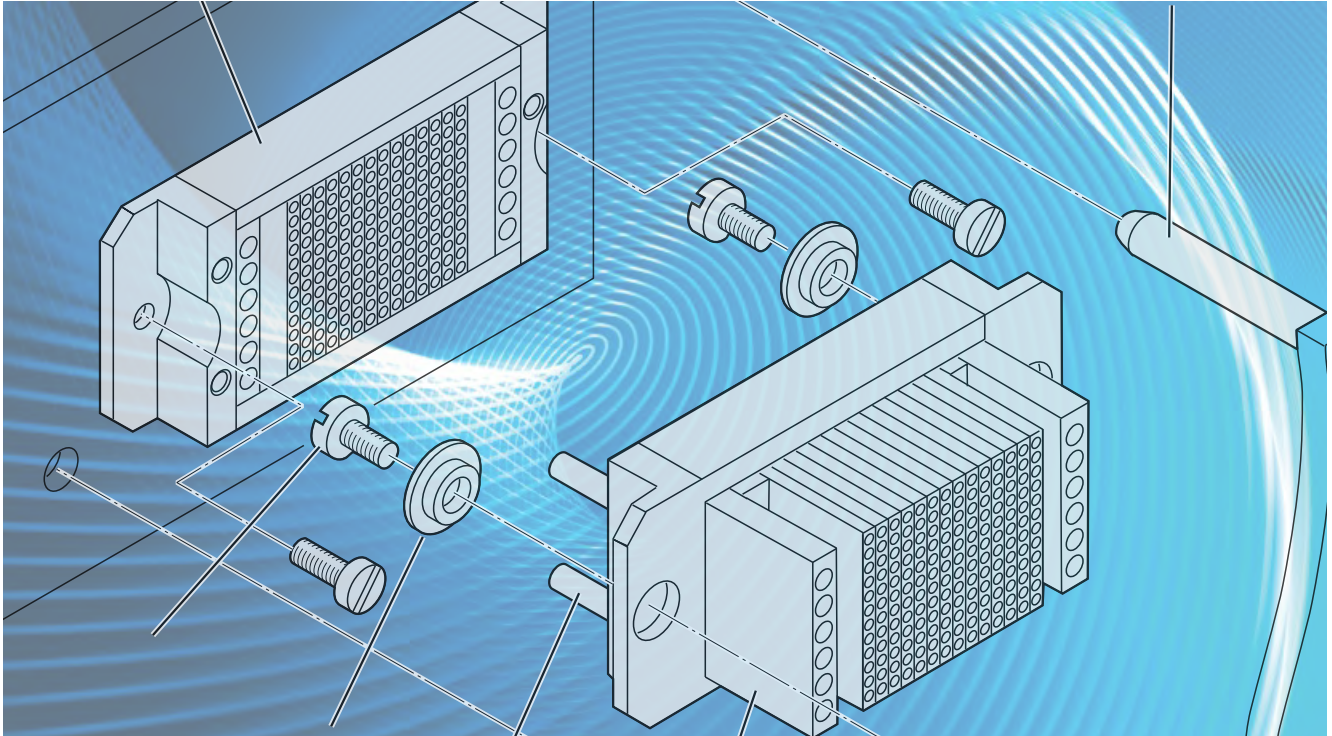

Aluminium Frame



The ODU-MAC in the aluminium frame is used exclusively for automatic docking. For manual mating, see ODU-MAC in the DIN housing, starting on page [91](#).



Part Number System for All Aluminium Frame Sizes

The part number for all frames is composed of the following information:

The first three digits indicate if the item is a pin frame or a socket frame.

Digits 4 to 6 indicate the frame model (type S, M, P, etc.).

Digits 7 to 9 indicate the number of units and consequently the frame length (total length of the modules).

The example shows a pin frame (611) in the standard model (020) with a length of 14 units (014).

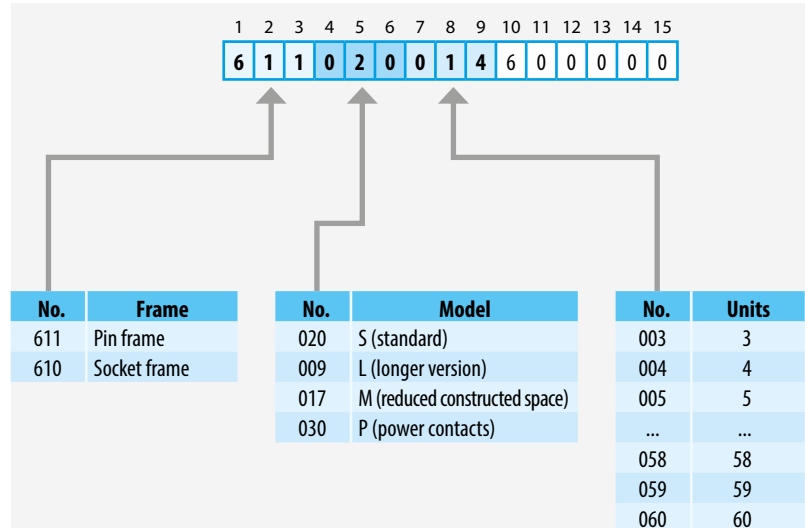

Height of the Pins for All Frame Sizes (Aluminium Frame and Solid Frame)

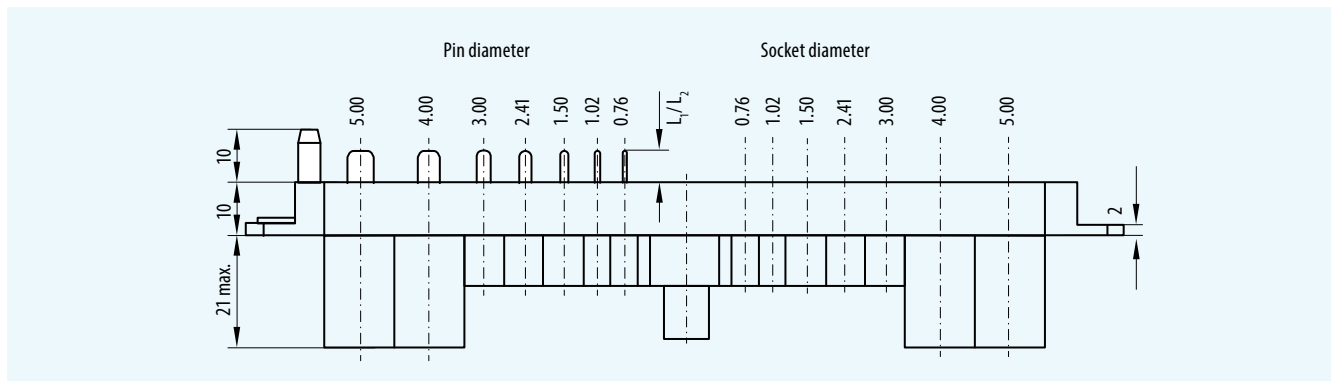

All pins project 6 mm (L_1).

Protruding earth pins have a projecting length of 8 mm (L_2).

The diameters of the pins or sockets are as follows:

- 0.76 mm 1.02 mm 1.50 mm
- 2.41 mm 3.00 mm 4.00 mm
- 5.00 mm

Other lengths and diameters are available in special modules (coaxial, power, etc.)!

Requirements for the Guidance and Tolerances Between Wall B and Wall S for ODU-MAC S (Standard Model)

The values apply to the mated state (pin S in B) and result from the axial play of the centring sockets.

The customer is responsible for the strain relief!

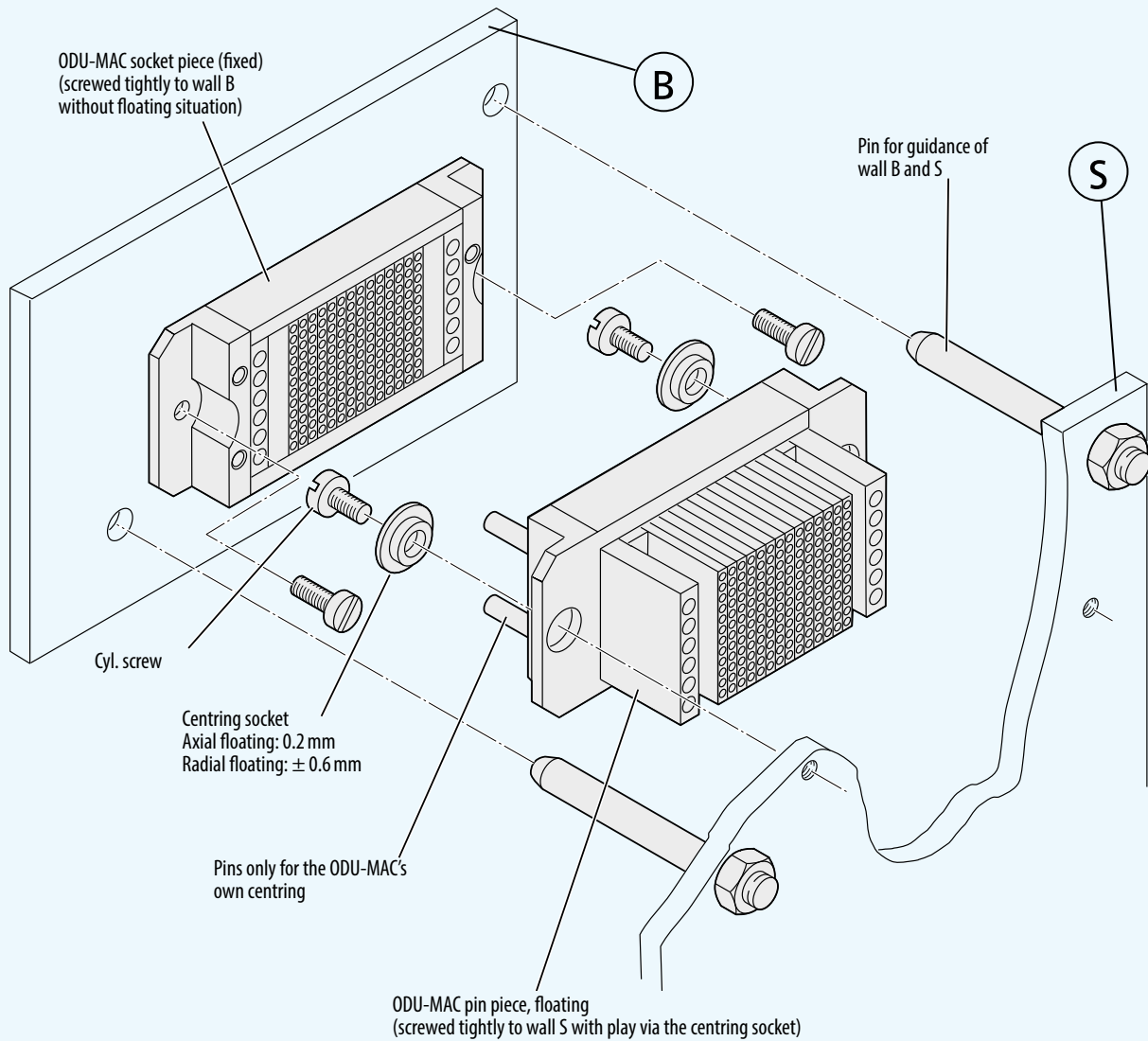

Aluminium Frame

Note: Automatic docking processes

- The pin piece of the ODU-MAC S is to be fastened to the accompanying centring sockets and consequently has a floating mounting.
- The guide system of the ODU-MAC does not provide any guidance for the overall slide-in module.
- There must be a certain advance guidance by means of the slide-in unit (e.g., by means of guidance rails, etc.). The max. permitted misalignment is, e.g., for the ODU-MAC S frame, less than ± 0.6 mm radial. A tilting of max. 4° in the connector's longitudinal direction and 2° in the connector's transverse direction is permissible.
- The max. permissible gap between the socket piece and the pin piece is 0.5 mm.

ODU-MAC S Aluminium Frame, Standard Version

Aluminium Frame

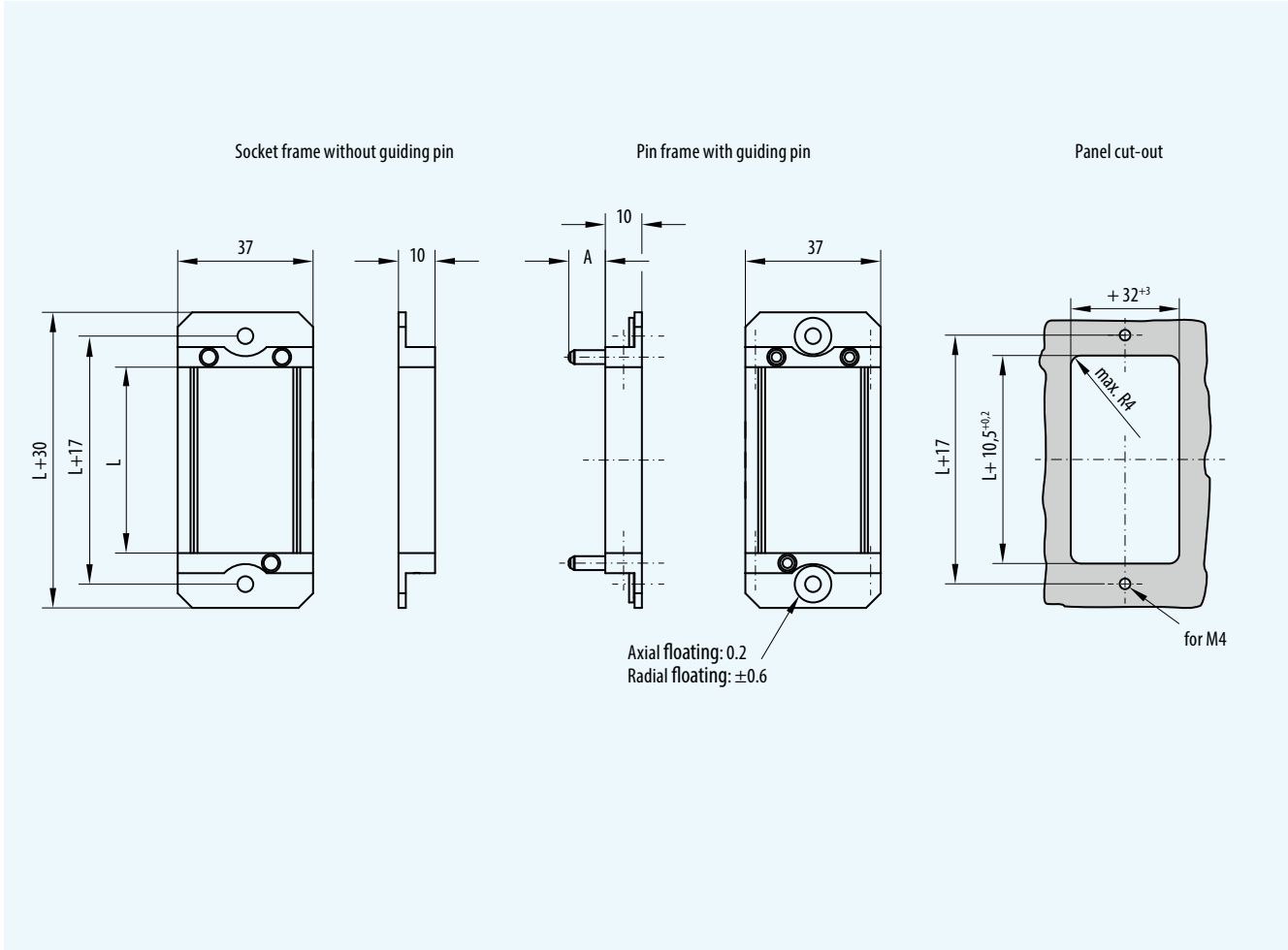

	Part number	Dimension A mm	Notice	Order information
Pin frame	611.020 OXX 600.000	10		L = Number of units × 2.54 XX = for entering the number of required units (03 – 60)
Socket frame	610.020 OXX 600.000			
Pin frame	611.021 OXX 600.000	12.5		
Socket frame	610.021 OXX 600.000			
Pin frame	611.025 OXX 600.000	21	For spindle locking	
Socket frame	610.025 OXX 600.000			
Pin frame	611.050 OXX 600.000	10	With labelling	
Socket frame	610.050 OXX 600.000			

ODU-MAC L Aluminium Frame Special Model with Elongated Guiding Pins and Guiding Sockets for Greater Radial Floating

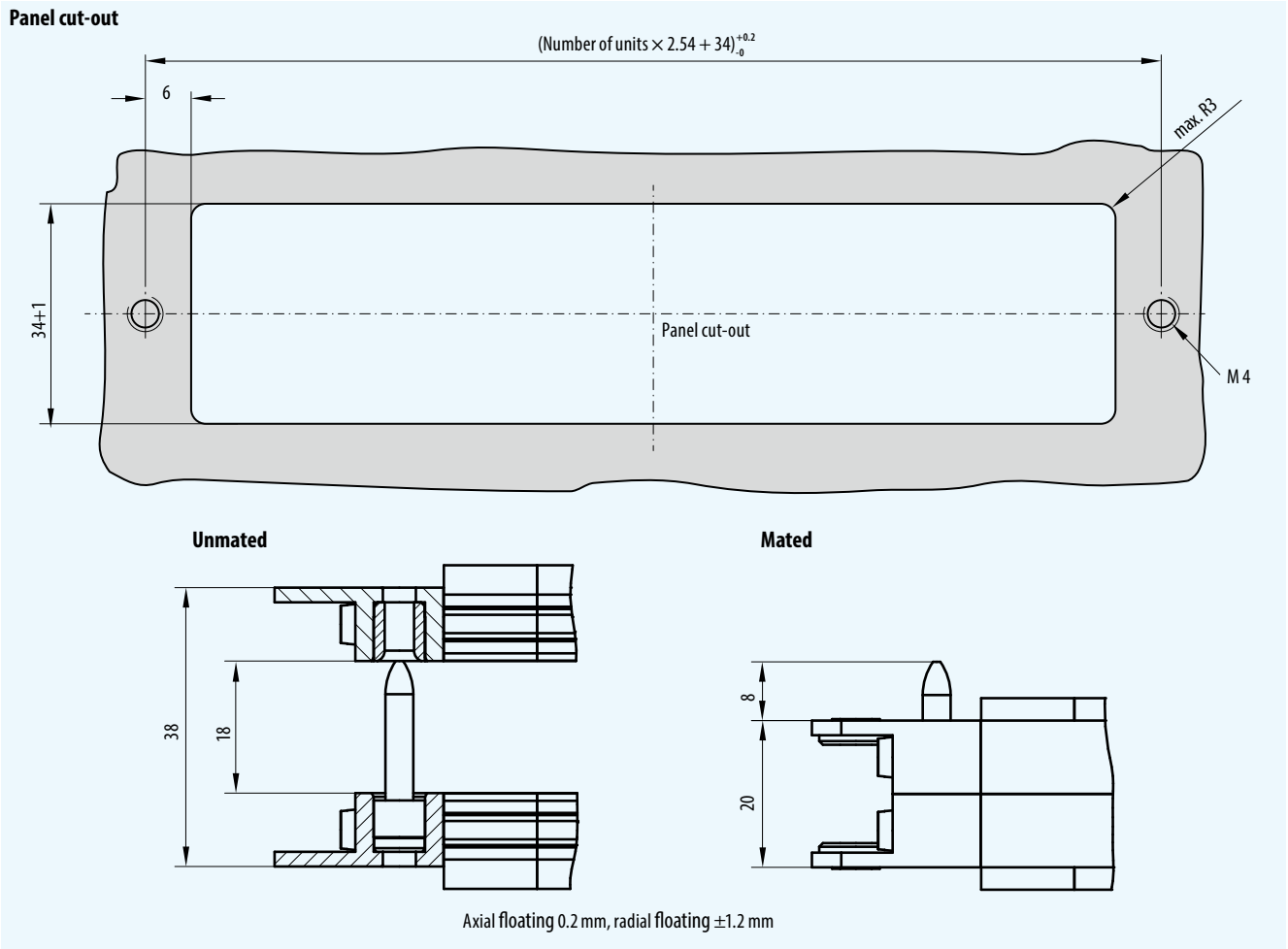

Aluminium Frame

Equipping example

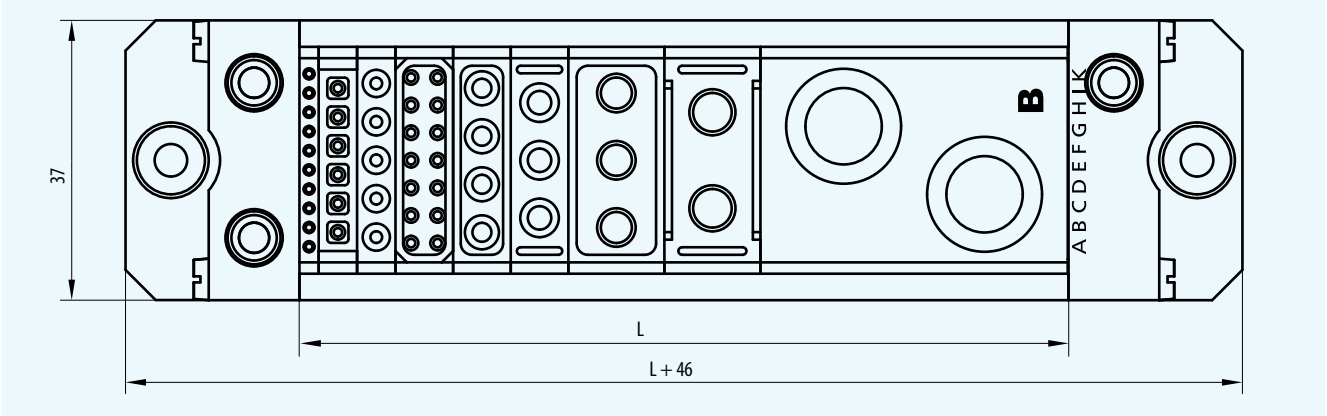

	Part number	Order information
Pin frame	611.009 OXX 600.000	L = number of units \times 2.54
Socket frame	610.009 OXX 600.000	XX = for entering the number of required units

32 coding positions are possible on request.

ODU-MAC M Pin Frame and Socket Frame for More Compact Spaces

Aluminium Frame

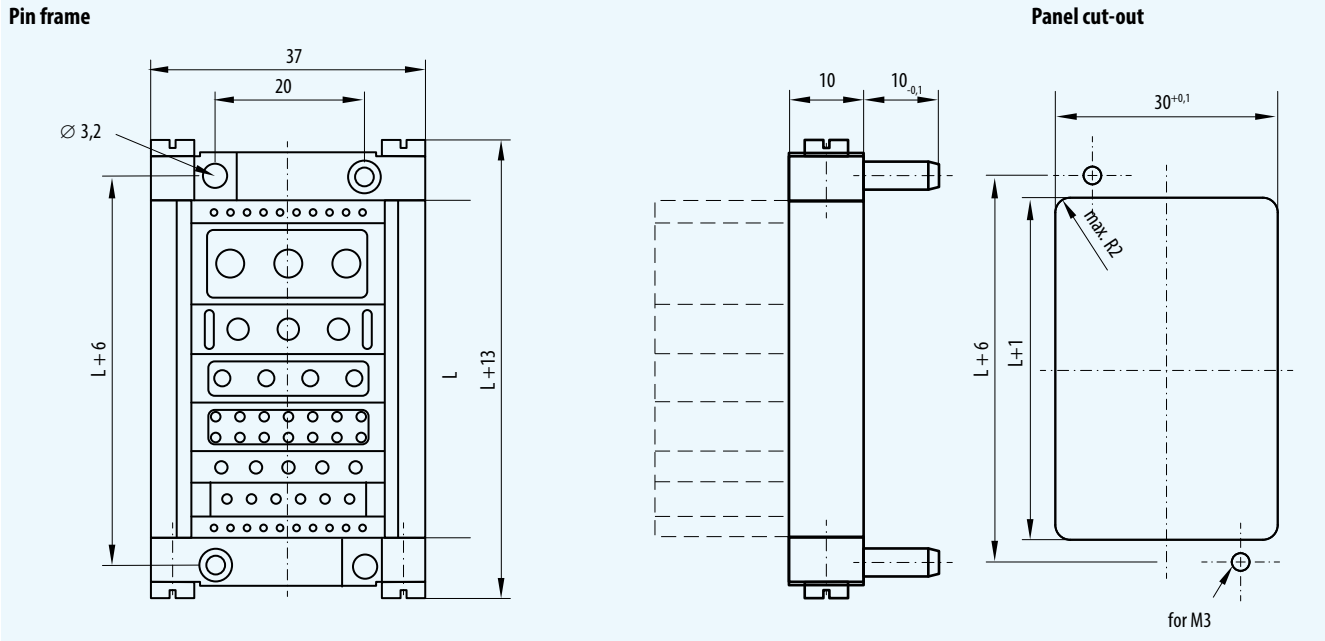

	Part number	Order information
Pin frame	611.017 OXX 600.000	L = number of units \times 2.54 XX = for entering the number of required units

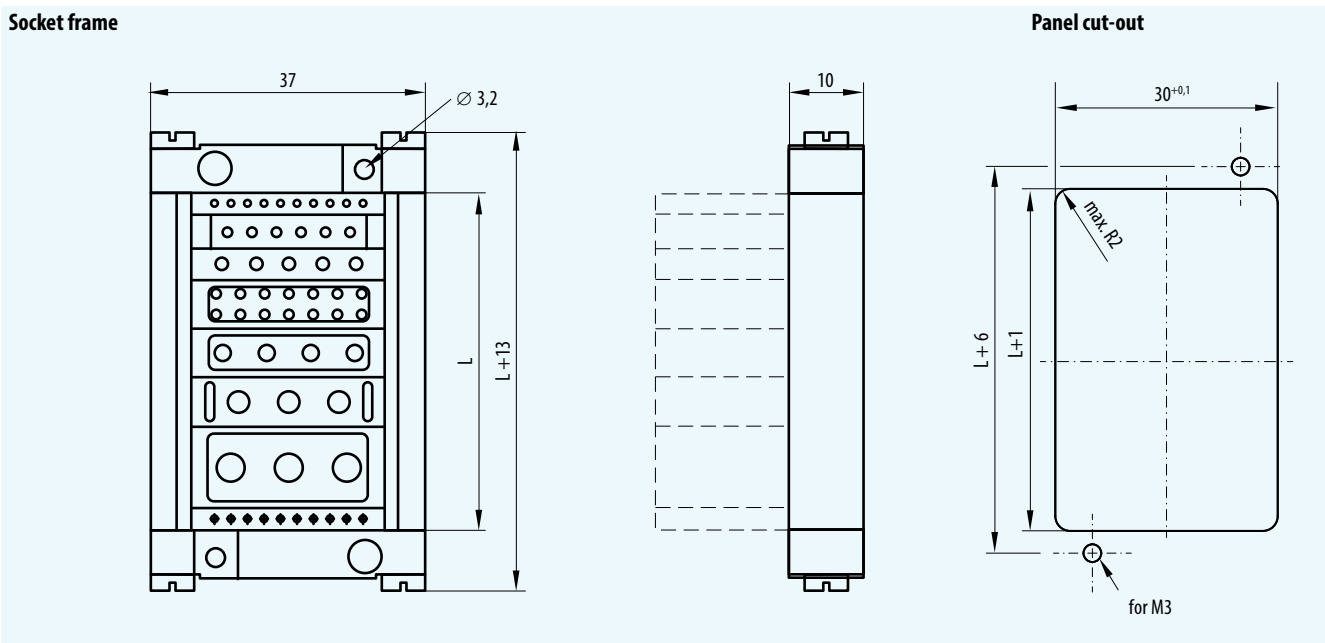

	Part number	Order information
Socket frame	610.017 OXX 600.000	L = number of units \times 2.54 XX = for entering the number of required units

ODU-MAC P Pin Frame and Socket Frame for Power Contacts and More Stringent Mechanical Requirements

Pin frame

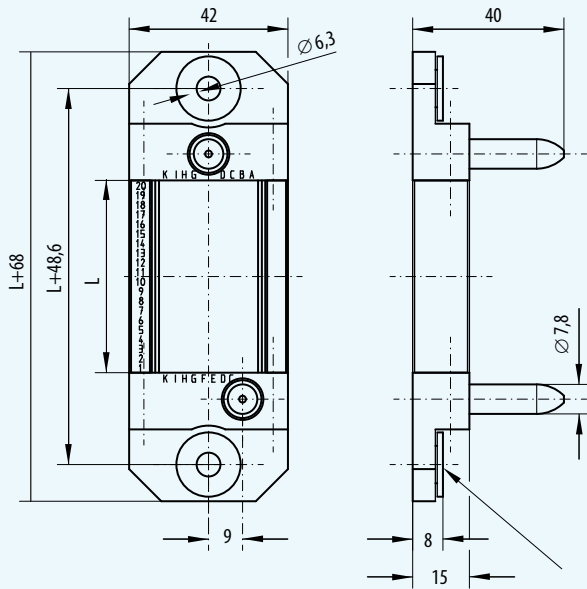

Socket frame

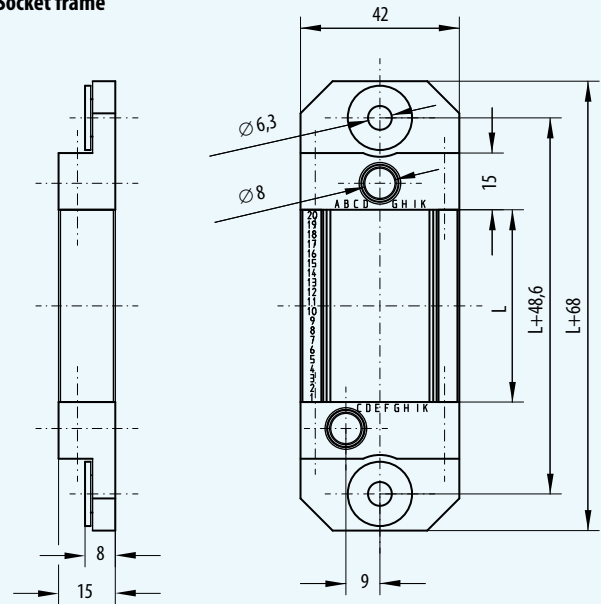

Axial floating 0.5 mm – Radial floating +/- 1.25 mm
 Floating mounting – reliable offset of pin piece and socket piece 2.5 mm

Aluminium Frame

	Part number	Order information
Pin frame	611.030 0XX 600.000	L = Number of units × 2.54 XX = for entering the number of required units (05 – 60)
Socket frame	610.030 0XX 600.000	

Special use, if a number of power contacts are installed within an ODU-MAC connector. This frame is recommended for a contact diameter of 5 mm or more. This frame must be used for a contact diameter of 8 mm or more.

- Units: from 5 to 60
- Longer and thicker guiding pins:
 Ø 7.8 mm / 25 mm long
- Attachment with M6 screws
- With labelling

Panel cut-out

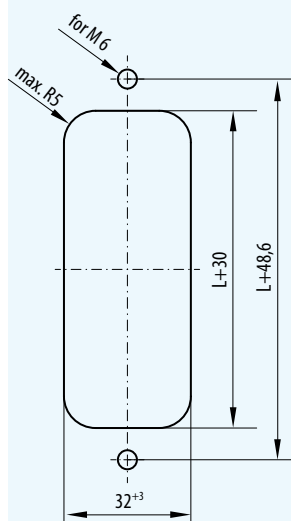

ODU-MAC Transverse Frame

Aluminium Frame



Part number pin frame	Part number socket frame	Dimension L mm	Units
611.055.029.103.600	610.055.029.103.600	7.75	3 × 2
611.055.029.104.600	610.055.029.104.600	10.30	4 × 2
611.055.029.105.600	610.055.029.105.600	12.85	5 × 2
611.055.029.106.600	610.055.029.106.600	15.40	6 × 2
611.055.029.107.600	610.055.029.107.600	17.90	7 × 2
611.055.029.108.600	610.055.029.108.600	20.45	8 × 2
611.055.029.109.600	610.055.029.109.600	23.00	9 × 2
611.055.029.110.600	610.055.029.110.600	25.45	10 × 2

Pin and socket frame

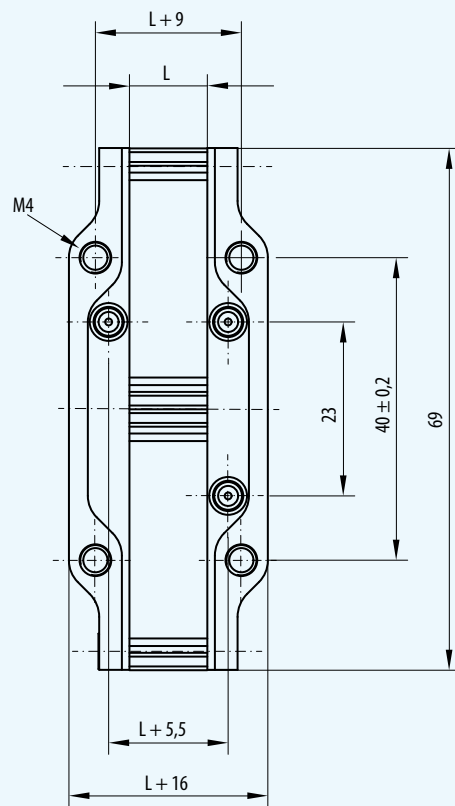

ODU-MAC in the DIN Housing



DIN Housing



The ODU-MAC in the DIN housing is used exclusively for the manual mating procedure. For automatic docking, see ODU-MAC in the aluminium frame starting on page [83](#).



ODU-MAC Frame for Housing in Accordance with DIN with Housing Earthing System

DIN Housing

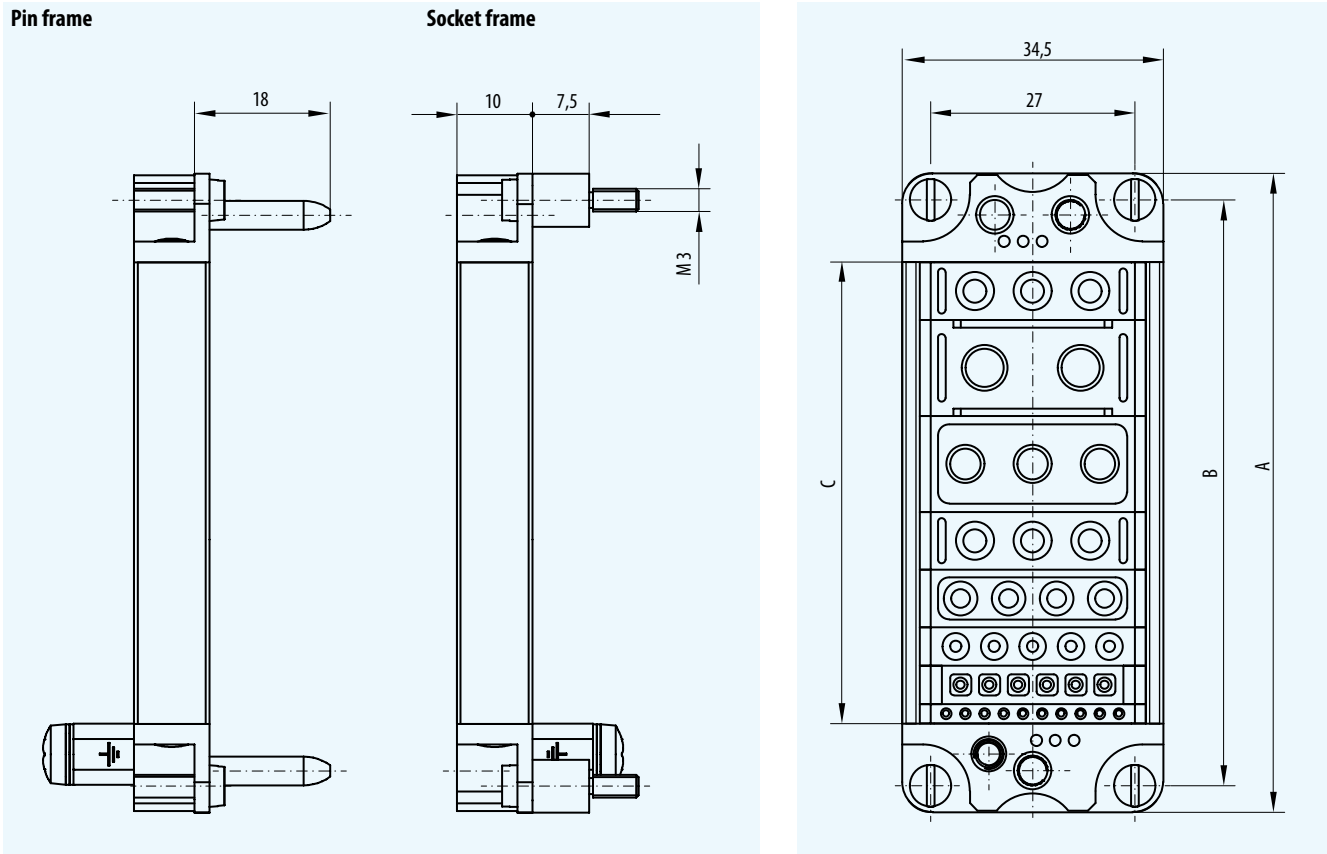

Sockets in bulkhead mounted housing or surface mounted housing. Pins in cable hood. See next page for coding possibilities. Delivery without modules.

The same dimensions for the height of the pins apply as for those of the aluminium frame (see page 84).

Size	Part number socket frame	Part number pin frame	Max. units à 2.54 mm	Dimension A mm	Dimension B mm	Dimension C mm
1	610.190.000.600.000	611.190.000.600.000	10	51.0	44.0	25.5
2	610.191.000.600.000	611.191.000.600.000	16	64.0	57.0	40.8
3	610.192.000.600.000	611.192.000.600.000	24	84.5	77.5	61.1
4	610.193.000.600.000	611.193.000.600.000	34	111.0	104.0	86.5

Coding Possibilities for Solid Frame in DIN Housing

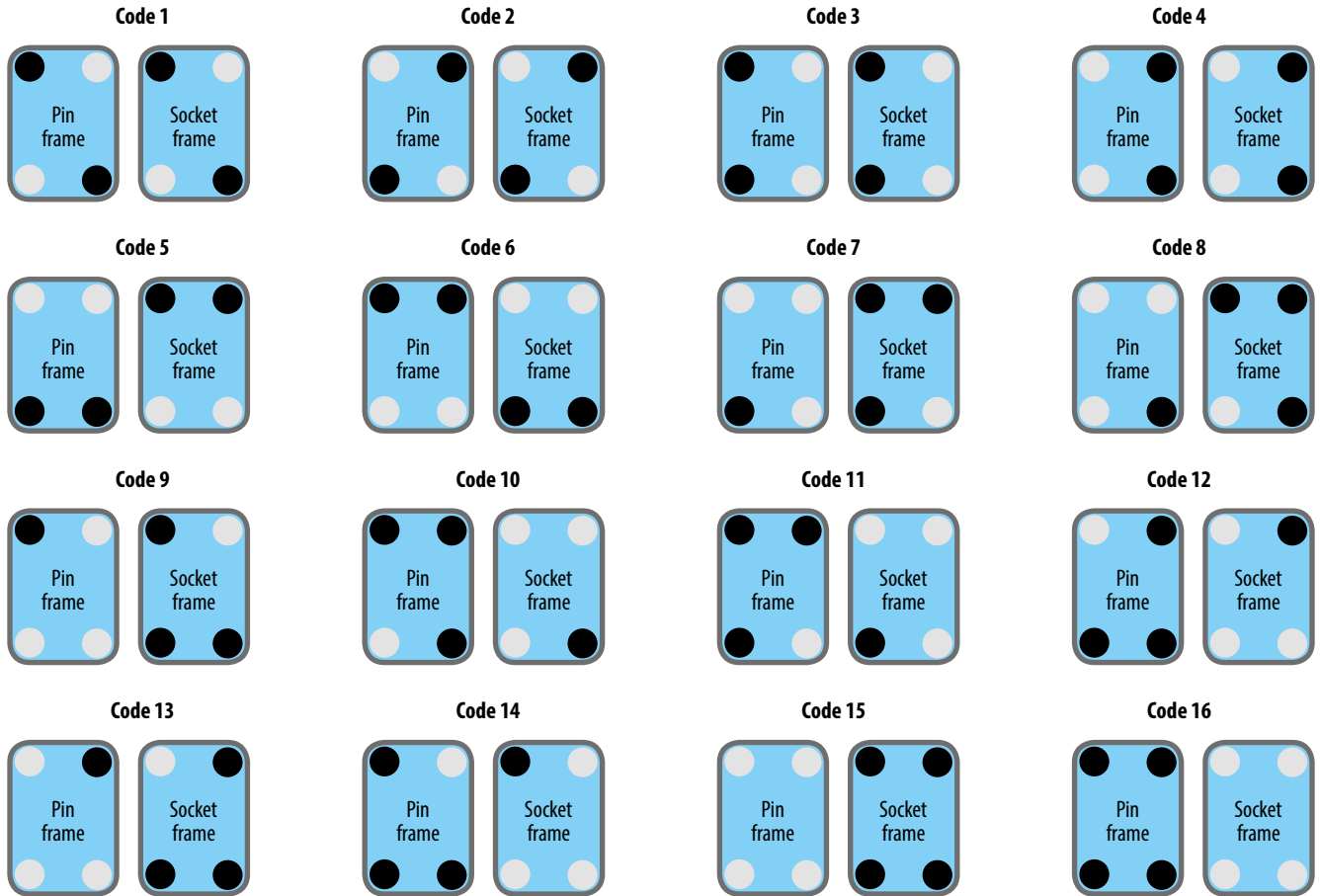

DIN Housing

Frame	Part number	Coding	
		● Pin	● Socket
Pin	611.19X.000.600.000	611.090.301.704.000 	610.090.302.704.000
		611.090.302.704.000 	610.090.301.704.000
Socket	610.19X.000.600.000		

Coding upon special order.
 Replace cylinder screws with coding sockets or coding pins.
 Part number for assembly tool: 611.090.098.700.000

ODU-MAC DIN Housing Bulkhead Mounted Housing with Lever Locking

Colour of housing:
grey (standard)

Protection class:
IP 65 in mated condition

Material:
Aluminium pressure die casting

Sealing:
NBR



DIN Housing

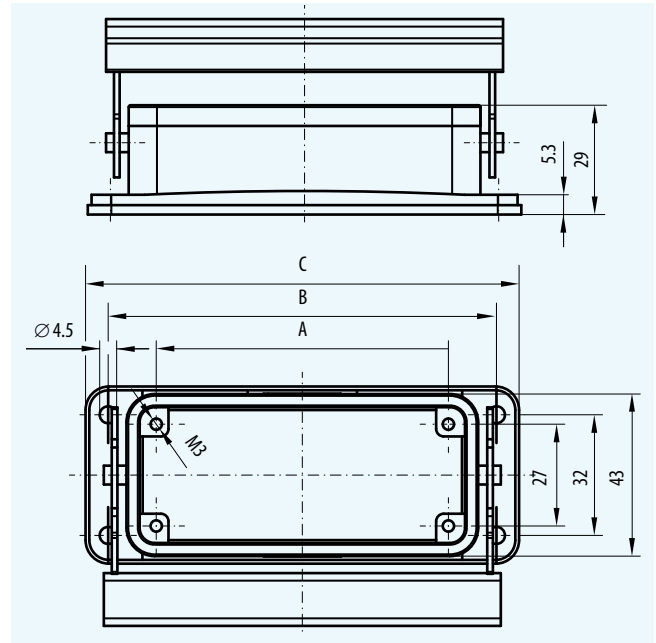
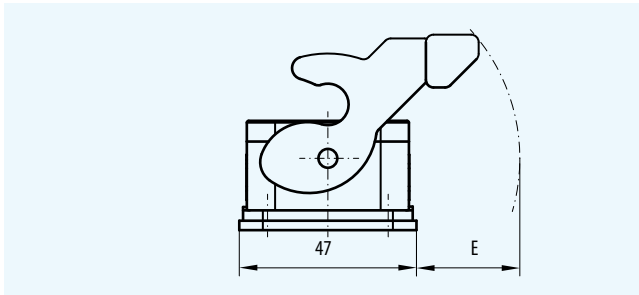

Panel cut-out

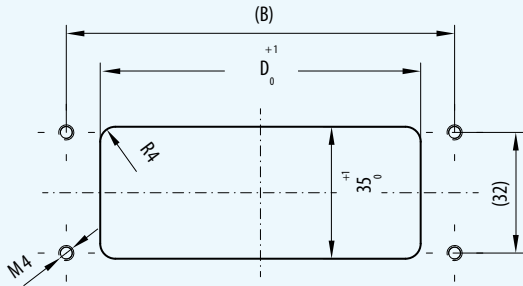

Size	Part number bulkhead mounted housing	Part number bulkhead mounted housing with protective cover	Dim. A mm	Dim. B mm	Dim. C mm	Dim. D Panel cut-out mm	Dim. E mm
1	490.130.400.644.000	490.131.400.644.000	44.0	70	82	52.2	~21
2	491.130.400.644.000	491.131.400.644.000	57.0	83	95	65.2	~28
3	492.130.400.644.000	492.131.400.644.000	77.5	103	115	85.5	~28
4	493.130.400.644.000	493.131.400.644.000	104.0	130	143	112.2	~28

Cable Hood with Top and Side Entry for Lever Locking

Colour of housing:
grey (standard)

Protection class:
IP 65 in mated condition
(depends on cable clamp used)

Material:
Aluminium pressure die casting

Sealing:
NBR

Cable clamp:
see page [101](#)

Adapter for PG gland:
see page [102](#)

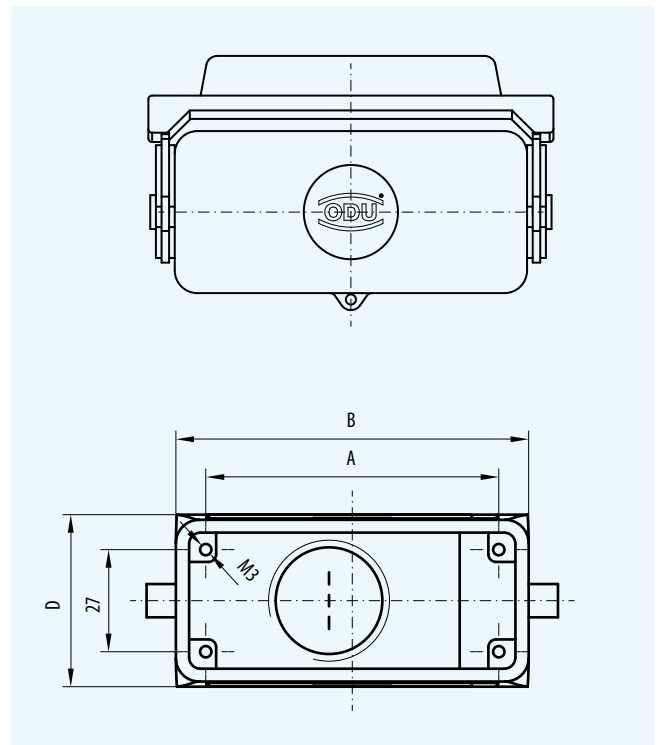
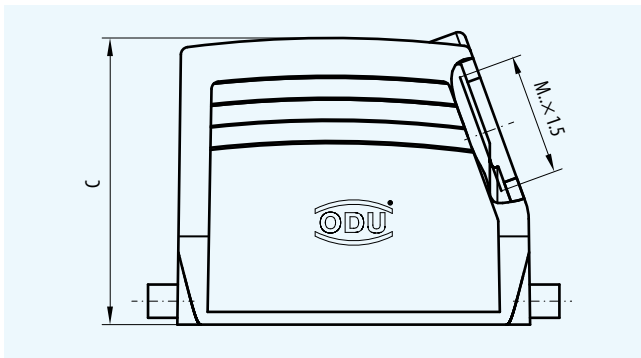
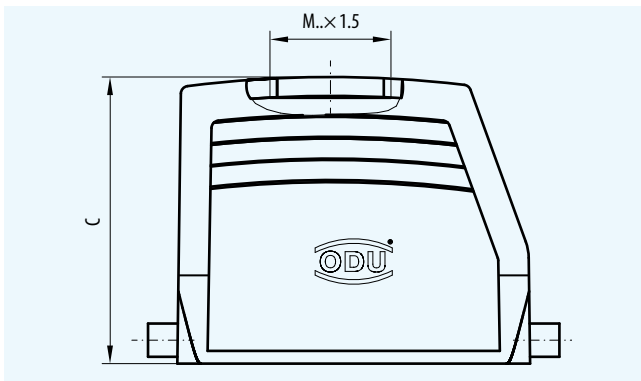
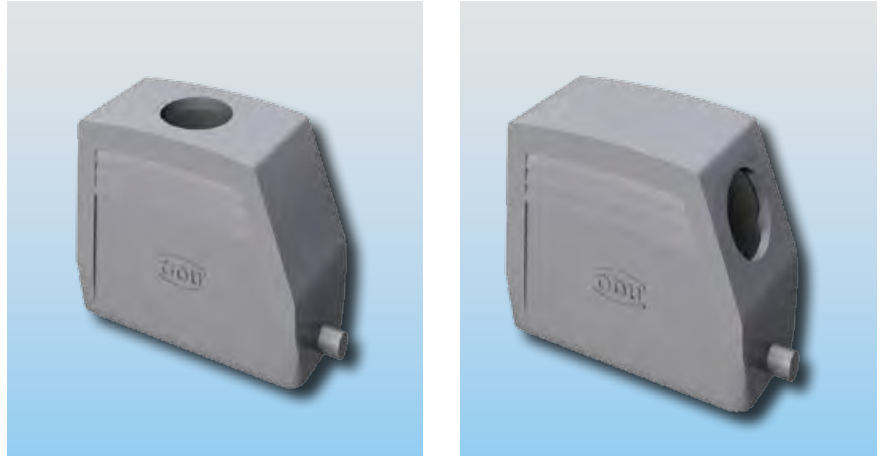

DIN Housing

Size	Part number right angled exit	Part number straight exit	Dim. A	Dim. B	Dim. C	Dim. D	Dim. M Exit	Part number Protective cover
			mm	mm	mm	mm		
1	490.414.450.644.102	490.214.450.644.102	44.0	60.0	52.0	43.0	M 25 × 1.5	490.097.500.644.000
	490.415.450.644.102	490.215.450.644.102			72.0		M 32 × 1.5	
2	491.414.450.644.102	491.214.450.644.102	57.0	73.0	52.0	43.0	M 25 × 1.5	491.097.212.644.000
	491.415.450.644.102	491.215.450.644.102			72.0		M 32 × 1.5	
3	492.415.450.644.102	492.215.450.644.102	77.5	93.5	76.0	45.5	M 32 × 1.5	492.097.214.644.000
4	493.415.450.644.102	493.215.450.644.102	104.0	120.0	76.0	45.5	M 32 × 1.5	493.097.214.644.000

Surface Mounted Housing with Two Side Cable Entries for Lever Locking – with or without Protective Cover

- Colour of housing:
grey (standard)
- Protection class:
IP 65 in mated condition
(depends on cable clamp used)
- Material:
Aluminium pressure die casting
- Sealing:
NBR
- Sealing plug, cable clamp
and adapter for PG:
see page [102](#)



DIN Housing

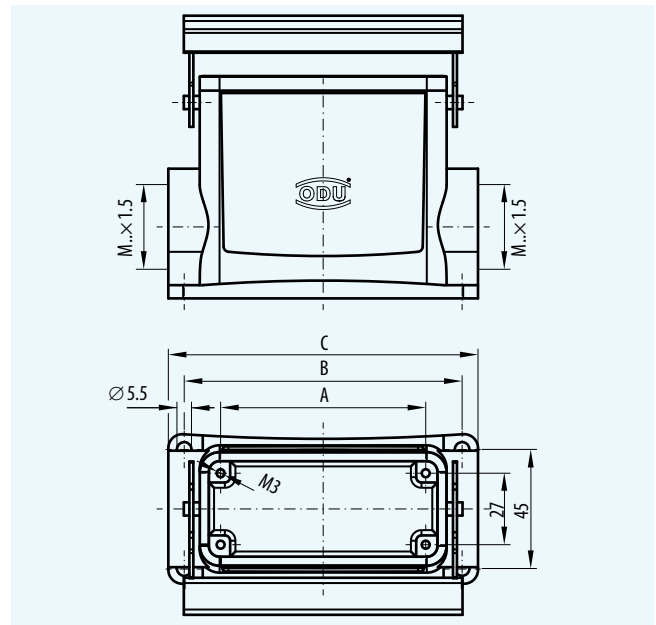
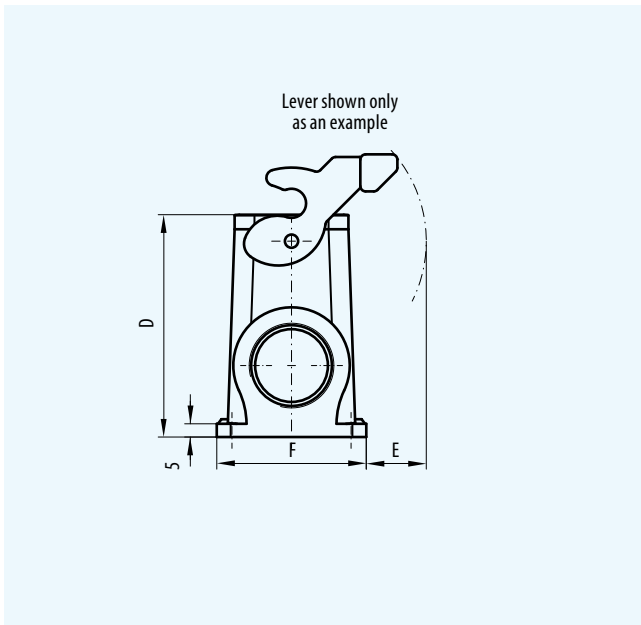

Size	Part number without protective cover	Part number with protective cover	Dim. A	Dim. B	Dim. C	Dim. D	Dim. E	Dim. F	Dim. M Exit
			mm	mm	mm	mm	mm	mm	
1	490.133.450.644.102	490.135.450.644.102	44	70	82	74	~ 17	55.5	
2	491.133.450.644.102	491.135.450.644.102	57	82	92.5	74	~ 23	55.5	32×1.5
3	492.133.450.644.102	492.135.450.644.102	77.5	105	117	84	~ 23	56.5	
4	493.133.450.644.102	493.135.450.644.102	104	132	144	84	~ 23	58	

ODU-MAC DIN Housing with Spindle Locking

Colour of housing grey (standard) or white
 Material Aluminium pressure die casting
 Sealing NBR
 Cable clamp see page [101](#)
 Surface mounted housing on request

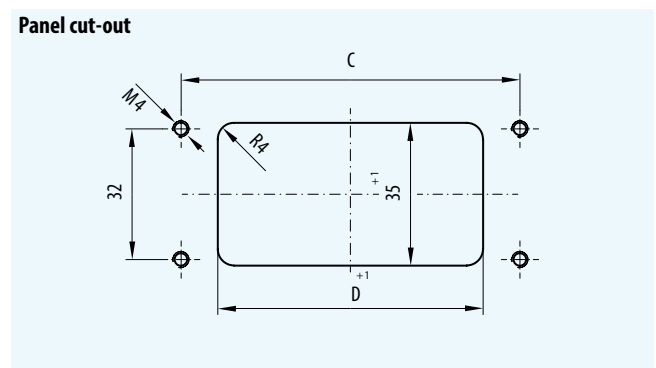
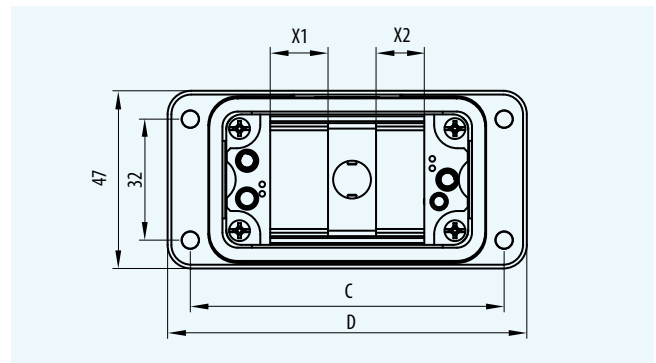
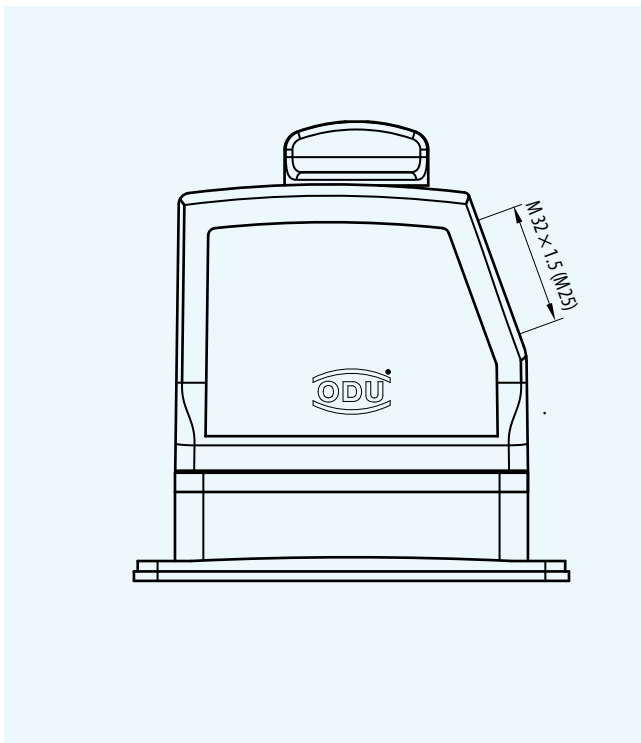

DIN Housing

Size	Part number cable hood	Part number bulkhead mounted housing	Dim. A mm	Dim. B mm	Dim. C mm	Dim. D Panel cut-out mm	X1 mm	X2 mm	M Exit	Spindle head
Colour of housing white:										
2	613.091.513.653.203	612.091.010.653.000	52	73	83	60	6	5	M 25 × 1.5	white
2	613.091.514.653.203	612.091.010.653.000	72	73	83	60	6	5	M 32 × 1.5	
3	613.092.514.653.203	612.092.010.653.000	76	93.5	103	82	10	9	M 32 × 1.5	
4	613.093.514.653.203	612.093.010.653.000	78	120	130	108	15	14	M 32 × 1.5	
Colour of housing grey:										
2	613.091.513.644.208	612.091.010.644.000	52	73	83	60	6	5	M 25 × 1.5	black
2	613.091.514.644.208	612.091.010.644.000	72	73	83	60	6	5	M 32 × 1.5	
3	613.092.514.644.208	612.092.010.644.000	76	93.5	103	82	10	9	M 32 × 1.5	
4	613.093.514.644.208	612.093.010.644.000	76	120	130	108	15	14	M 32 × 1.5	

Cable to Cable Hood with Top Cable Entry

For setting up a cable to cable connection.
Suitable for the cable hood (page 95).

Protection class IP 65 in mated condition
Material Aluminium pressure die casting
Sealing NBR

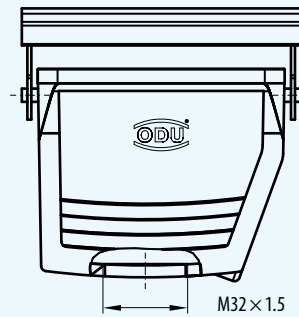
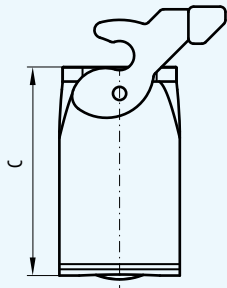

Protective cover

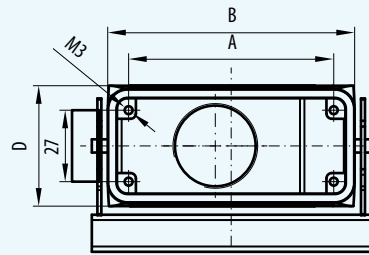
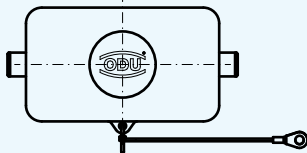

DIN Housing

Size	Part number cable to cable hood	Dim. A	Dim. B	Dim. C	Dim. D	Part number Protective cover
1	490.331.450.644.102	44	60	75	43.0	490.097.500.644.001
2	491.331.450.644.102	57	73	75	43.0	491.097.133.644.000
3	492.331.450.644.102	77.5	93.5	79	45.5	492.097.133.644.000
4	493.331.450.644.102	104	120	79	45.5	493.097.133.644.000

Spindle Locking

Version 1 for socket in bulkhead mounted or surface mounted housing and pin in cable hood

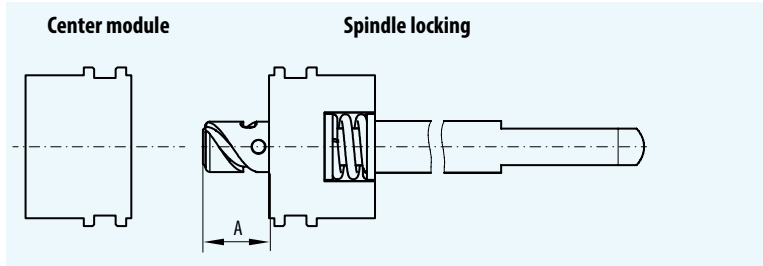

Max. number of mating cycles 30,000¹⁾
 Space requirement 5 units
 (5 × 2.54 mm)
 Special version on request

Size	Part number center module for bulkhead mounted and surface mounted housing	Part number spindle locking for cable hood	Rotational angle	Dim. A mm
2 (52 mm height)	614.090.001.304.000	615.091.003.200.000	180°	12.0
2 (72 mm height)	614.090.001.304.000	615.091.001.200.000	180°	12.0
3/4	614.090.001.304.000	615.092.021.200.003	360°	21.5

¹⁾ Up to 30,000 cycles, depending on the mating force of the modules used. Replacement set available on request.

DIN Housing

Version 2 for pins in bulkhead mounted or surface mounted housing and socket in cable hood

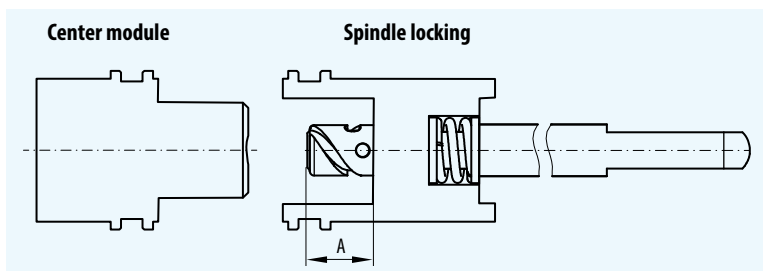
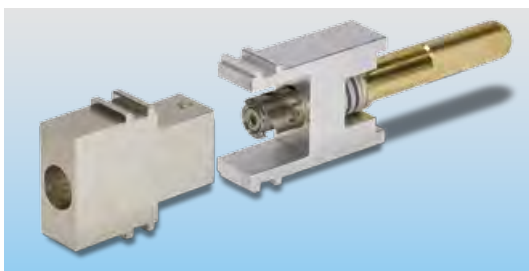

Max. number of mating cycles 30,000¹⁾
 Space requirement 5 units
 (5 × 2.54 mm)
 Special version on request

Size	Part number center module for bulkhead mounted and surface mounted housing	Part number spindle locking for cable hood	Rotational angle	Dim. A mm
2 (52 mm height)	614.090.002.304.000	615.091.004.200.000	180°	12.0
2 (72 mm height)	614.090.002.304.000	615.091.002.200.000	180°	12.0
3/4	614.090.002.304.000	615.092.022.200.003	360°	21.5

¹⁾ Up to 30,000 cycles, depending on the insertion force of the modules used. Replacement set available on request.

EMC Housing / Corrosion Protection Housing (available on request!)

EMC model

- Electrically conductive surface
- Internal sealing
- Housing of die-cast aluminium alloy
- Temperature range: -50°C to +120°C
- Shielding attenuation approx. 65 dB

Corrosion protection model

- Screw and lever locking
- Pressure-sealed > 5 bar
- Corrosion protection - colour: black
- IP 68, DIN EN 60529
- IP 69K, DIN 40050 Part 9
- Sealing: silicone

Application areas

Used for sensitive interfaces that have to be shielded from electromagnetic fields.

New: IP 68 housing with enhanced corrosion protection and outstanding EMC properties

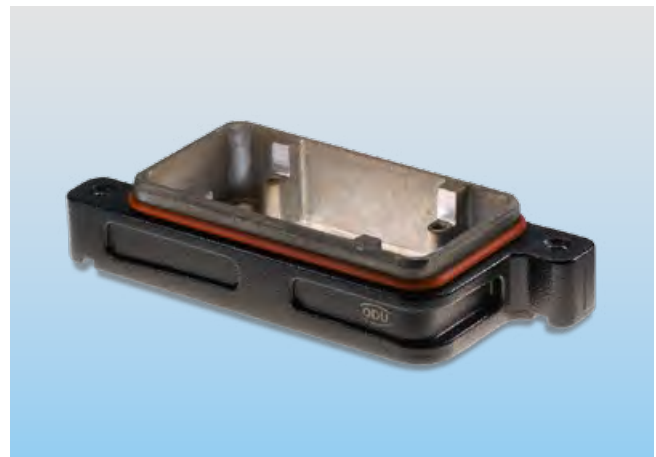

DIN Housing

Insertion loss

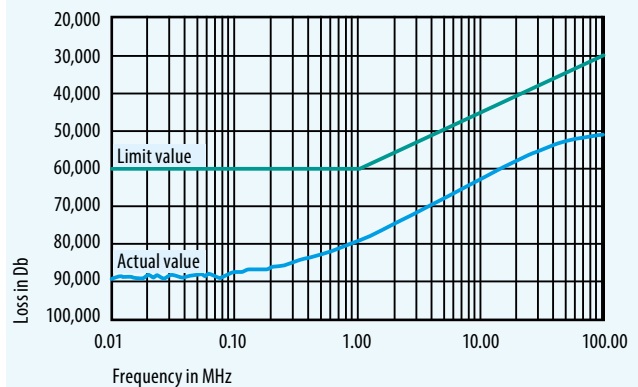

Cable Clamp for DIN Housing in Accordance with EN 50262

Temperature range -40° C to +100° C

Protection class IP 68 up to 5 bar

Material

- Body PA
- Sealing NBR

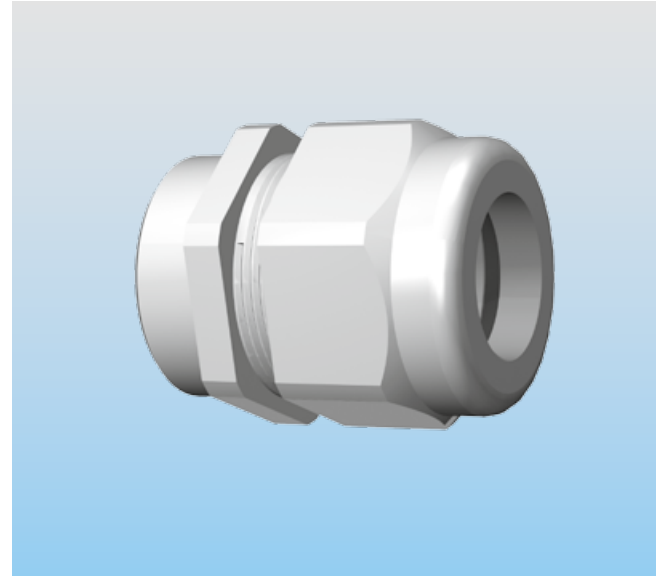

Part number	Thread	Colour	Width across flats	Tightening torque	Cable diameter	
					mm	min.
027.825.060.130.007	M 25 × 1.5	grey	30	8	6	13
027.825.090.170.007					9	17
027.832.070.150.007	M 32 × 1.5		36	10	7	15
027.832.110.210.007					11	21
027.825.060.130.003	M 25 × 1.5	white	30	8	6	13
027.825.090.170.003					9	17
027.832.070.150.003	M 32 × 1.5		36	10	7	15
027.832.110.210.003					11	21

DIN Housing

Protective Cover (Transport Cover)

Material Plastic

Size	Part number with holding roupe	Part number without holding roupe
1	490.097.900.924.000	490.097.900.924.101
2	491.097.900.924.000	491.097.900.924.101
3	492.097.900.924.000	492.097.900.924.101
4	493.097.900.924.000	493.097.900.924.101



Blind Grommet for Surface Mounted Housing

Material PA, fibre-glass reinforced
Colour grey

Part number	Protection class	Thread
921.000.006.000.279	IP 54	M 32 × 1.5
921.000.006.000.268	IP 54	M 32 × 1.5



DIN Housing

Adapter Ring

For cable clamps with PG thread

Material nickel-plated brass
Sealing NBR

Part number	External thread	Internal thread
921.000.006.000.254	M 25 × 1.5	PG 21
921.000.006.000.255	M 32 × 1.5	PG 29



Application Specific Solutions



Application Specific Solutions Based on the ODU-MAC



One-piece insulators equipped with standard ODU-MAC contacts. Customers install this insulator block into their own housing.

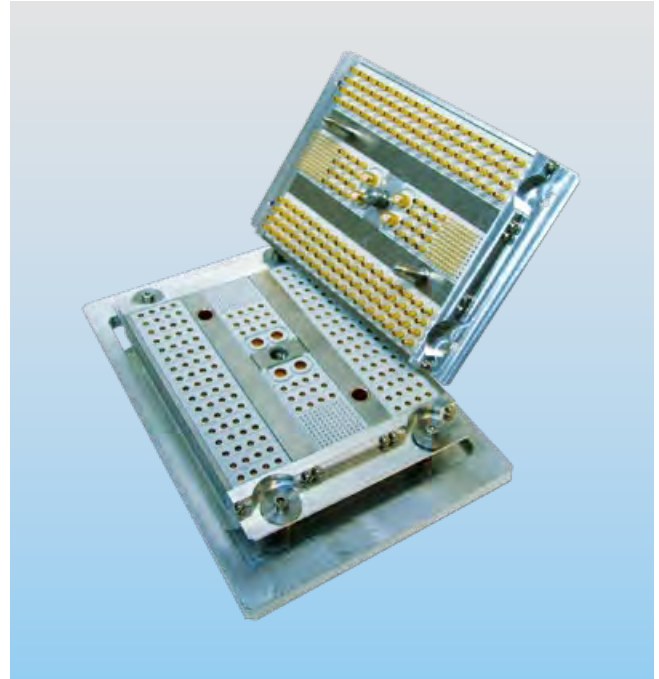

Complete docking unit. Three ODU-MAC series units, including special spindle locking, are assembled into a special frame made of stainless steel.

Application Specific Developments



The MRI device features an ergonomic design and gentle diagnostic procedures without side-effects. The interface between the MRI device and the individual body coils is formed by an application specific connector based on the ODU-MAC.

Advantages

- At least 50,000 mating cycles
- 64 coding possibilities
- Non-magnetic
- 1 GHz
- High packing density



The interface between the MRI device and the individual body coils is formed by an insulator developed for this specific application and equipped with coaxial and signal contacts. The customer integrates the insulator into a special housing.

Advantages

- At least 50,000 mating cycles
- Non-magnetic
- 1 GHz
- High packing density

ODU-MAC Quick-Change Head (Aluminium Frame)

With mixed inserts, in quick-change head version for extremely high number of mating cycles, exchangeable connector piece

The quick-change head consists of 4 frames. Plug-in frames and socket frames are separated or connected by dismantling or connecting at the interface between the second and third frame.

Parts 1 and 2 always remain together, as do parts 3 and 4.



In the event of wear on the contacts, the two interchangeable parts 2 and 3 are pulled off of part 1 and 4. They can then be replaced with the new interchangeable parts quickly and easily without any assembly effort.

The connection is ready for use again within seconds.



Tools, Crimp Information, Processing Instructions



Crimp Information

Contact diameter	Termination cross section		Stripping length	8 pt. crimp tool 080.000.051.000.000	6 pt. crimp tool	6 pt. crimp tool 080.000.026.000.000	Hand crimp tool stamped contacts	Hand crimp tool for spool stamped contacts
	AWG	mm ²		Without positioner Positioner 080.000.051.101.000				
mm			mm	Position		Crimping jaws		
0.76 1.02 1.5	24/28	0.08/0.25	4 ^{+0.5}	1 2 3				
0.7	26/28						080.000.040.000.000	080.000.041.000.000
0.7	22/24						080.000.040.000.000	080.000.041.000.000
0.76	22	0.38	4 ^{+0.5}	1 3				
1.02 1.5 2.41 3	20/22	0.38/0.50	4 ^{+0.5} 5 ^{+0.5}	2 3 4 5				
1.5 2.41 3	18	1	4 ^{+0.5} 5 ^{+0.5}	3 4 5				
1.5	16		4 ^{+0.5}	3				
1.5 2.41 3	14	1.5	4 ^{+0.5} 5 ^{+0.5}	3 4 5				
2.41	12		5 ^{+0.5}		080.000.012.000.000			
2.41 3		2.5	5 ^{+0.5}	4 5				
3 5		4	4 ^{+0.5} 6 ^{+0.5}		080.000.011.000.000			
3		6	6 ^{+0.5}		080.000.011.000.000			
5		10	9 ^{+0.5}			080.000.026.110.000		
8		16	9 ^{+0.5}			080.000.026.116.000		
8								
10 12		25	16 ^{+0.5}			080.000.026.125.000		
10 12		35	16 ^{+0.5}			080.000.026.135.000		
12		50	16 ^{+0.5}			080.000.026.150.000		

Tools

Crimping Tools and Contact Processing

Contact processing for the production of connection lines by means of crimping creates a permanent, corrosion-free connection with stable contact. This time-saving termination can also be carried out by non-experts.

The cold pressing (crimping) compresses the conductor and contact material at the compression points so much that a gas-tight connection results that corresponds to the conductor material and that cannot be pulled apart. There is no need to reinforce the conductor material at the joint, such as occurs during soldering.

Crimping is suitable for the smallest and largest cross-sections.

For small cross-sections (0.08 – 2.5 mm²), the 8-point crimping tools are chosen, and the hexagonal tools are used for the larger cross-sections. When pressing larger cross-sections, gradual deformation with flowability that corresponds to the material is required; this avoids brittle tearing.

The assembly instructions can be downloaded from our website:

www.odu.de/downloadcenter.html



Side-view
8-point crimping



Cross-section
8-point crimping

Adjusting the crimping tool depending on the cable cross-section

1. Before using the hand press, you must insert the appropriate crimping jaws. Open the crimping jaw holder by pressing.
2. Then lay the halves of the insert into the crimping jaw holder and press them into the attachment bolt. Then close the holder.
3. Pump to build up the hydraulic pressure.
4. An audible "click" signals that the final pressure has been reached. The pressing procedure has been completed, and the tool can be returned to its starting position with the reset lever. The crimp termination is released.

Crimping Tool for Turned Contacts

8-point crimping tool

for conductor connections from 0.08 – 2.5 mm², with user-friendly digital display.

Part number:
080.000.051.000.000

Positioner for contact diameters from 0.76 – 3 mm has to be ordered separately

Part number:
080.000.051.101.000



Hexagonal crimping tool

for cross-sections (AWG12), 4.0 – 6.0 mm² with blocking system.

Part number for cross-section:
– AWG12:
080.000.012.000.000
– 4.0 – 6.0 mm²:
080.000.011.000.000

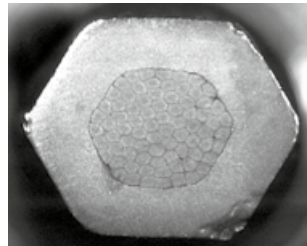

Cross-section
Hexagonal crimping

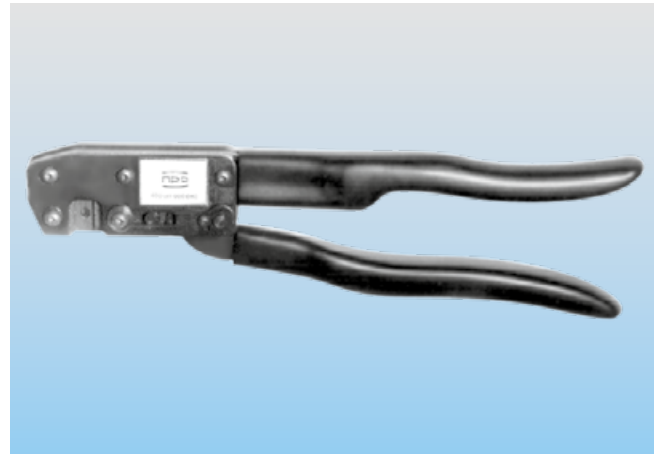

Hydraulic crimping tool

For 10 mm² cross-section with safety valve, which opens automatically once the pressure needed for perfect compacting has been reached.

Part number: 080.000.026.000.000

Part number for crimp die:
– 10 mm²: 080.000.026.110.000
– 16 mm²: 080.000.026.116.000
– 25 mm²: 080.000.026.125.000
– 35 mm²: 080.000.026.135.000
– 50 mm²: 080.000.026.150.000

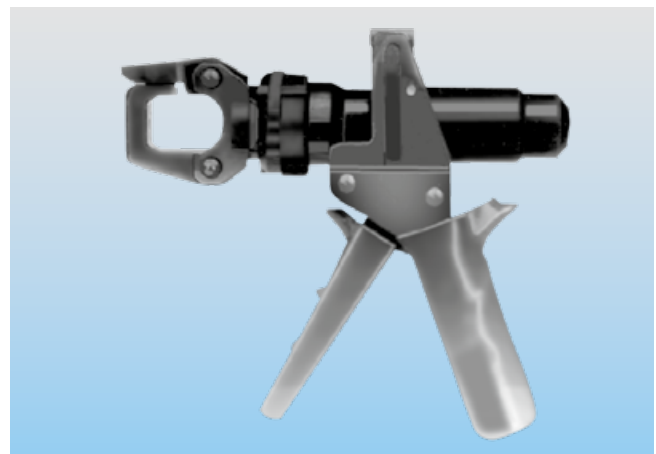

Crimping Tool for Turned Contacts

Hexagonal crimping tool
for coaxial contacts
with blocking system

Coaxial cable	Crimp dies
RG 178; RG 196; RG 174; RG 188; RG 316; RG 179; RG 187	082.000.039.101.000 082.000.039.102.000
G 00232 D	082.000.039.103.000
RG 122; 2YCY 0.4 / 2.5	082.000.039.104.000
RG 58; G03233 (H&S)	082.000.039.106.000
RG 223	082.000.039.108.000
RG 59	082.000.039.109.000

Part number:
080.000.039.000.000

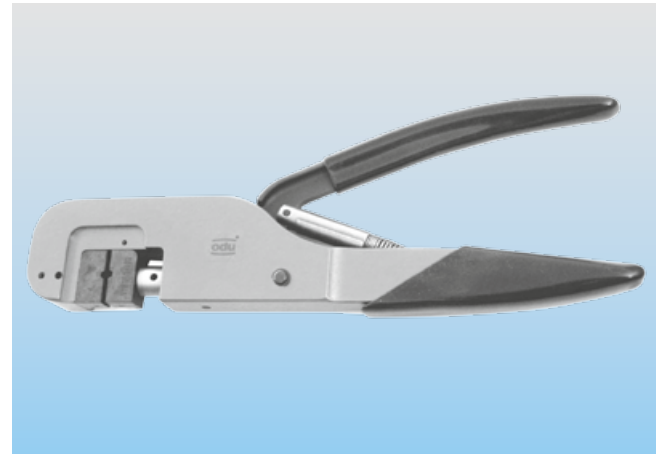

Hand crimping tool for single crimp contacts

Here single contacts are positioned in the tool manually and crimped.

Part number: 080.000.040.000.000

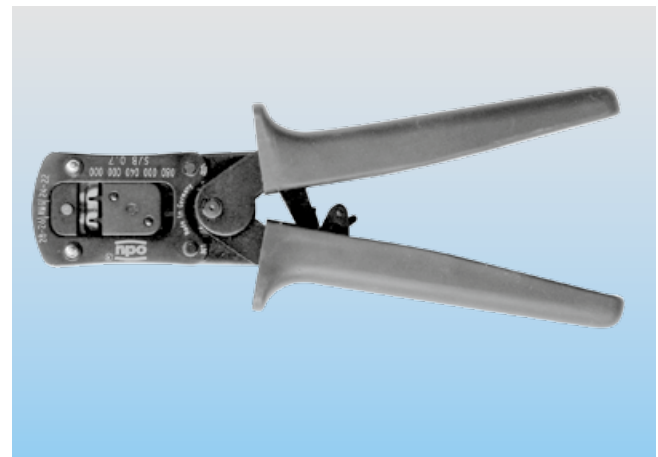

Hand-held crimping tool with roll fur spool goods

The contact is fed on a spool for the hand-held crimping tool and separated automatically during crimping. Manual activation produces the feeding.

Part number: 080.000.041.000.000.

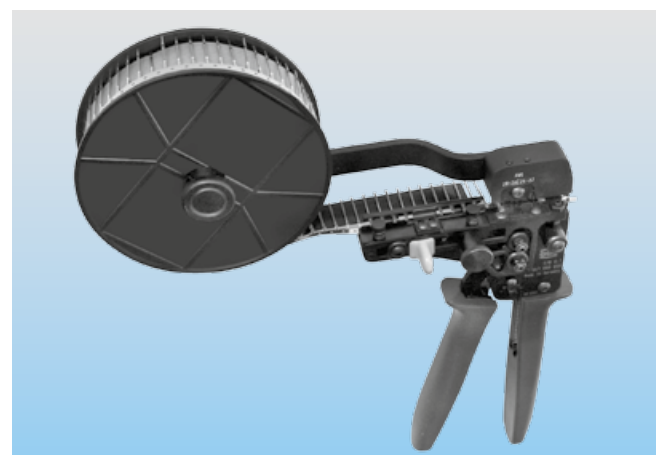

Crimp Termination According to DIN IEC 352

Pull-out force diagram for a crimp termination depending on the conductor cross-section (extract from DIN IEC 352 Part 2).

Example:
A 2.5 mm² conductor must have a minimum pull-out force of at least 320 N.

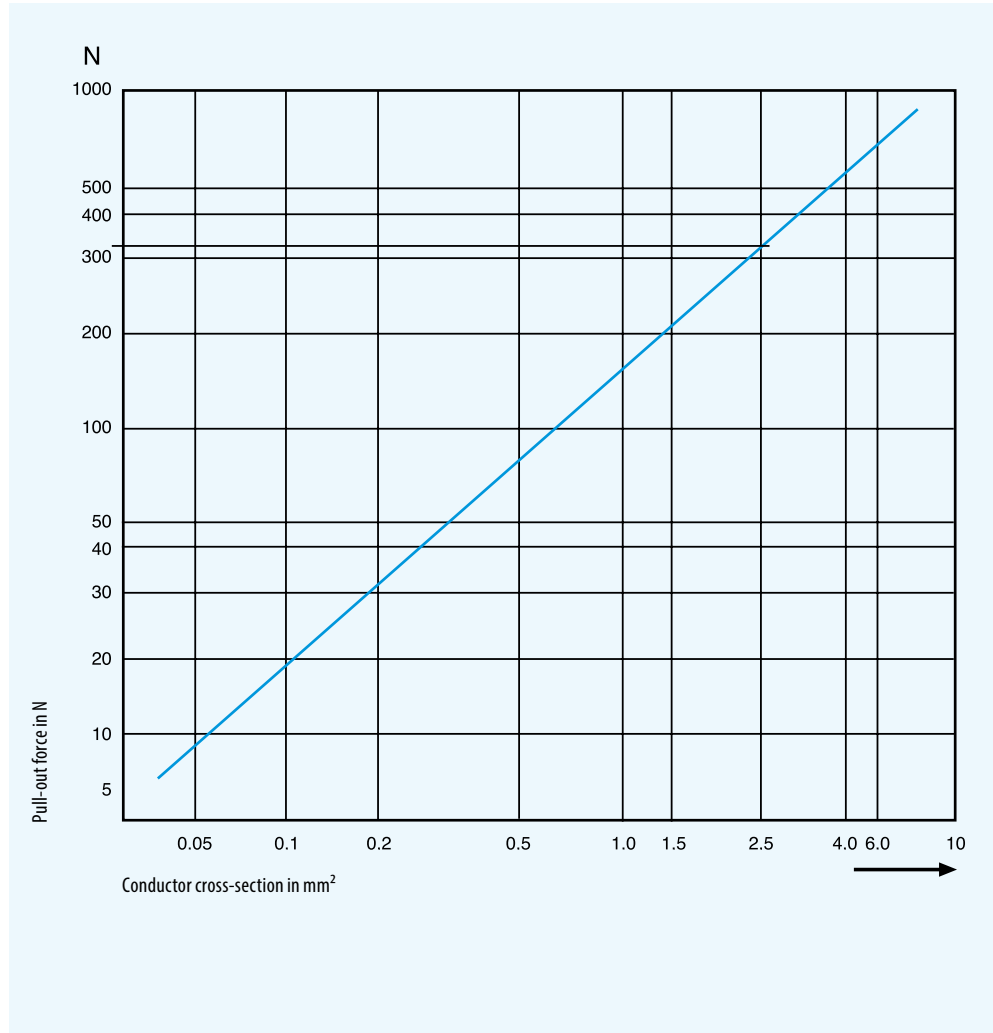

Contact Removal

Removal tool I

Removal of the already-assembled contact (including cable):

Press the removal tool into the insulator from the back until you hear a soft "click". You can remove the contact from the insulator by pulling on the cable.



Removal tool II

Removal of contacts that have not been assembled yet (without cable – it may be necessary to cut off the cable):

Press the removal tool into the insulator from the back until you hear a soft "click". Press lightly on the contact to remove it from the insulator.

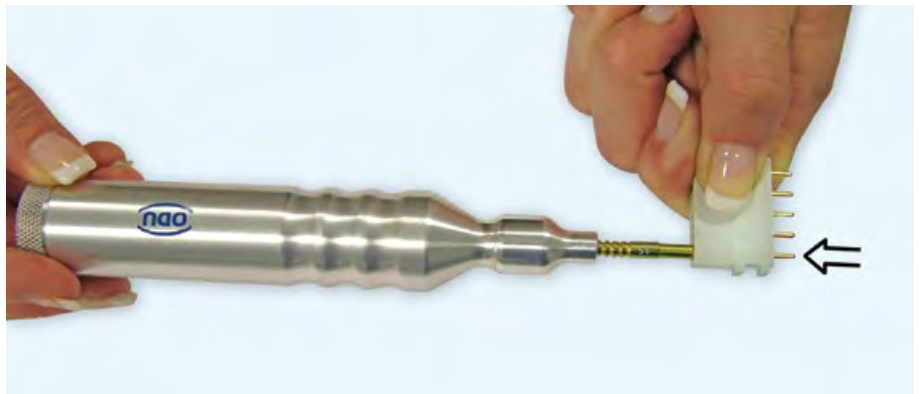

Coaxial Contact Assembly

For coaxial contacts 122.120

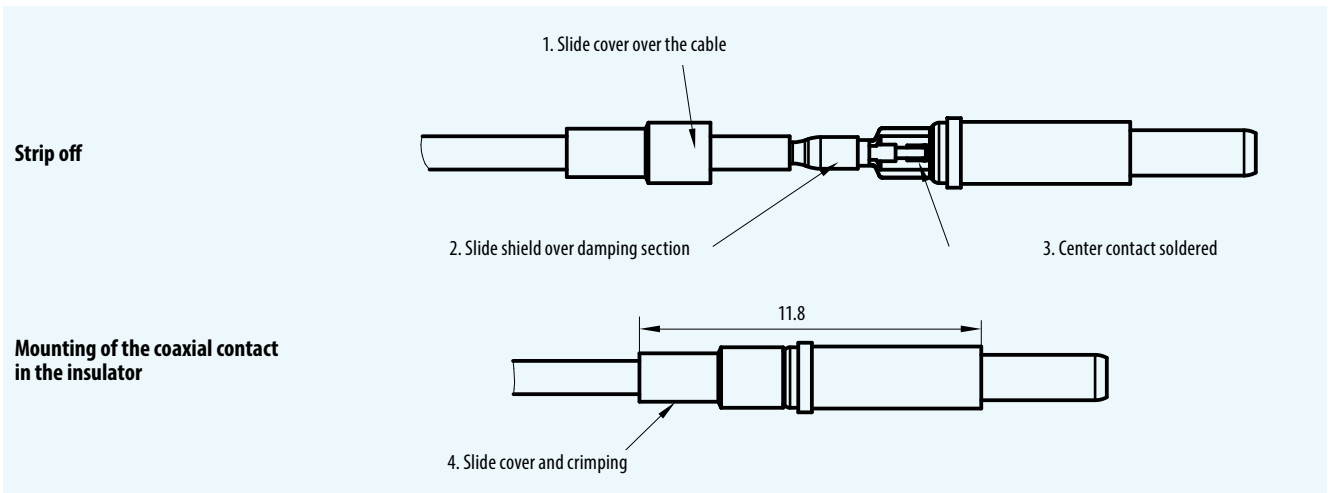
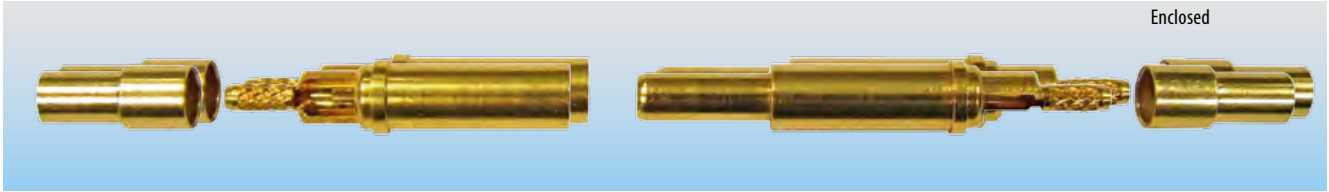

For coaxial contacts 122.126

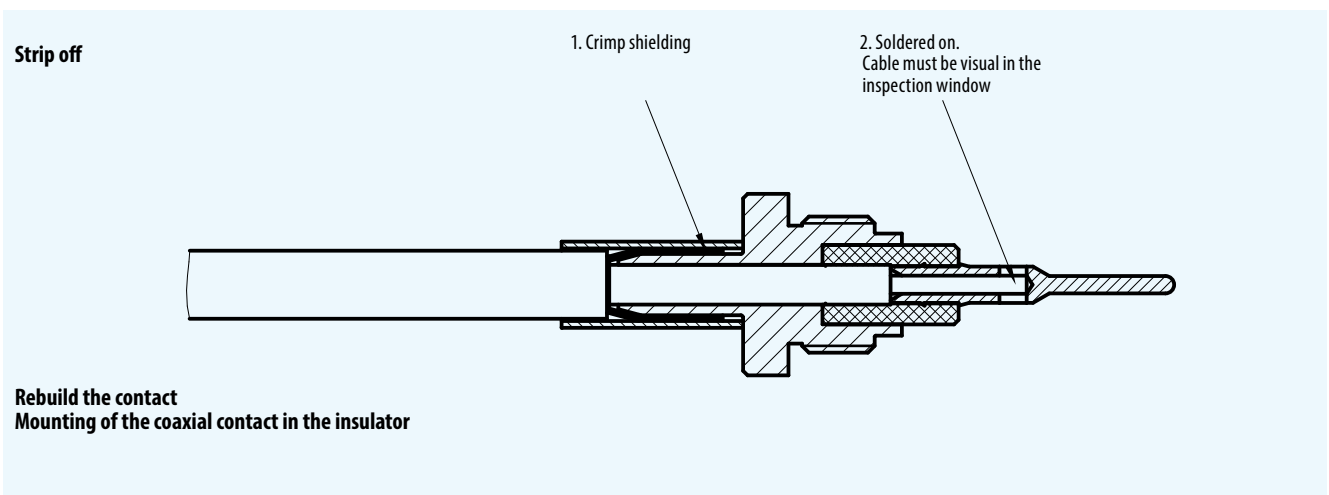
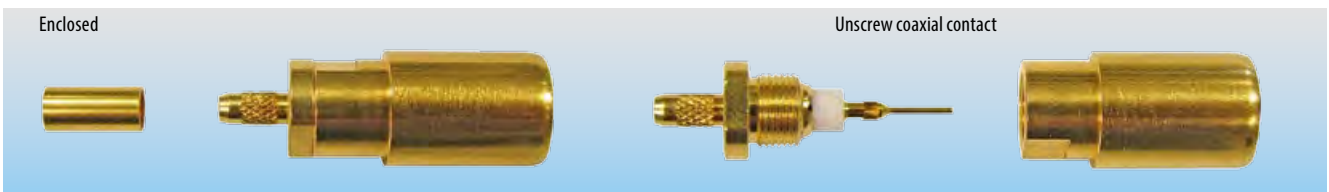

Detailed assembly instructions for all special contacts (coaxial, fibre optic, etc.) are available on request.

Maintenance Kit for Springwire and Lamella Contacts

Contact lubrication improves the mechanical characteristics of contact systems. We recommend that the contact surfaces also be cleaned before being lubricated in order to remove impurities. With proper care, it is possible to minimize significantly the wear caused by frequent matings and reduce the insertion forces. The cleaning and lubrication interval must be adapted individually to the conditions, and these steps should be carried out only with products recommended by the contact manufacturer.

ODU has put together a maintenance kit for this step so that lubrication can be carried out directly at your site. A cleaning brush and a special cleaning towel, together with precise instructions, allow optimal care of the contacts. The maintenance kit can be used for all ODU contacts and connectors as long as no other specifications apply.

Part number: 170.000.000.000.100

The technical characteristics of the maintenance kit are given on our website:
http://www.odu.de/fileadmin/template/pdf/einzel/Wartungspaket_Englisch.pdf



Cleaning information

Part number for maintenance instructions
 003.170.000.000.000
 Part number for maintenance kit
 170.000.000.000.100

Further information

Never immerse the connector in a fluid. Do not use the connector again until you have ensured that it has dried completely.

Make sure that contact pins have not been bent or otherwise damaged. The connector is not permitted to be used if damage or other signs of wear are visible. To avoid damage to the contacts, do not clean with compressed air above 2.5 bar.

Recommended cleaning agents

Soaps: watery soap based on bicarbonate of soda or potassium.

Alcohols: Ethanol 70%, isopropyl 70%.

Technical Information

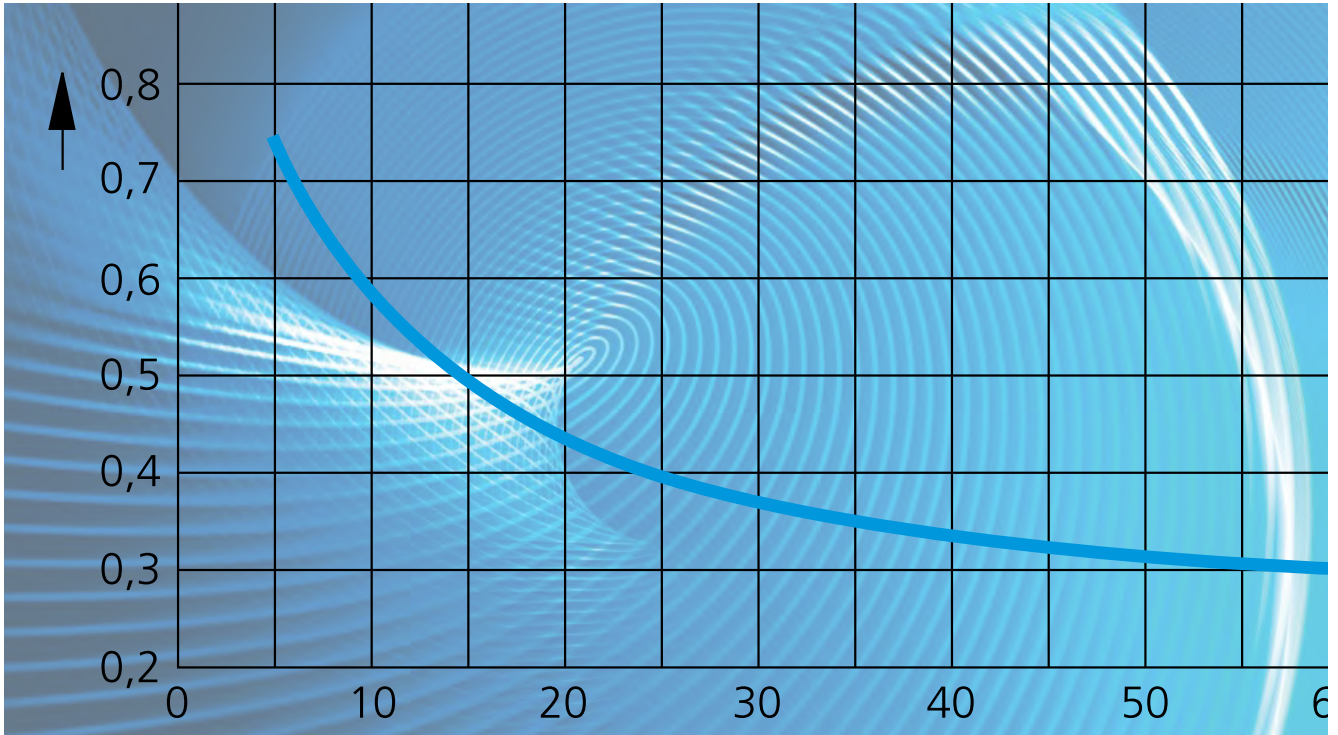

Explanations and Information in Compliance with VDE

Standards applied

DIN EN 60664-1 (VDE 0110 – part 1) and
 DIN EN 61984 (VDE 0627)
 (Original DIN EN 60664-1:2007 and DIN EN 61984:2009
 remain authoritative for all technical information given).

General information

A connector cannot be chosen by taking into consideration only functionality, number of contacts and current or voltage characteristics. The consideration of the place where it will be used and the installation conditions that prevail there are essential. Depending on the installation conditions and local conditions, the connector can be used in different voltage and current ranges, according to the standardization.

All voltage information listed in this catalog refers to use of insulators in ODU MAC massive frame for DIN housings or ODU MAC aluminium frames.

The most important influencing quantities and the electrical characteristics tuned to them are explained in more detail in the following. If you have further questions, we would be happy to provide support.

The following texts and tables are excerpts from the specified standards. The originals, DIN EN 60664-1 from Nov. 2003 and DIN EN 61984 from Sep. 2002, remain authoritative for all technical information given.

Overvoltage category

Using the overvoltage category, the necessary rated impulse voltage is defined according to table F.1 and the nominal voltage used. The particular overvoltage category for the device, depending on the installation location, is selected according to the criteria listed below.

– Overvoltage category I

Devices for connection to electric circuits in which measures have been taken to limit transient overvoltages to a suitable low level.

For example: Connectors for the power supply of computer hardware that is permanently connected to a power pack with electronic overvoltage limiting.

– Overvoltage category II

Devices that consume energy and that are supplied from the fixed wiring system.

For example: Household appliances, portable tools and similar devices.

– Overvoltage category III

(= standard, if no special overvoltage category is given).
 Devices in fixed wiring systems and for those cases in which particular demands are placed on the reliability and availability of the devices.

For example: Switches in fixed wiring systems and devices for industrial use with permanent connection to the fixed wiring system.

– Overvoltage category IV

Devices for use at the wiring system connecting point.
 For example: Electric meters and primary overvoltage protective devices

DIN EN 60664-1: Table F.1 – Rated impulse voltage for devices that are fed directly from the low-voltage system.

Nominal voltage of the electric power supply system according to IEC 60038		Voltage line to neutral, derived from nominal voltages a.c. or d.c. up to and including	Rated impulse voltage			
Three-phase-system	Single-phase-system		Overvoltage category			
V	V	V	I	II	III	IV
			V	V	V	V
		50	330	500	800	1500
		100	500	800	1,500	2,500
	120 – 240	160	800	1500	2,500	4,000
230/400 277/480		300	1,500	2,500	4,000	5,000
400/692		600	2,500	4,000	6,000	8,000
1,000		1,000	4,000	6,000	8,000	12,000

Pollution degree

Combined with moisture, any pollution that may arise can influence the insulating property on the surface of the connector. For defining the different rated values, a pollution degree must be selected for the device, according to the criteria listed below. For a connector with a degree of protection of at least IP 54 (to IEC 60529), the insulating parts inside the encapsulation may be measured for a lower pollution degree according to the standard. This also applies to inserted connectors where the encapsulation is ensured by the connector housing and that are detached only for testing and maintenance purposes.

– Pollution degree 1

There is either no pollution or only dry, non-conductive pollution; the pollution has no influence.
For example: Measuring instruments and hardware in computer systems.

– Pollution degree 2

Only non-conductive pollution occurs. Transient conductivity caused by dewfall must be expected occasionally, however.
For example: Devices in laboratories and in living areas and sales and other commercial areas.

– Pollution degree 3

(= standard, if no special pollution degree is given).
Conductive pollution occurs or dry, non-conductive pollution that becomes conductive because of dewfall must be expected.
For example: Devices in industrial, commercial and agricultural operations, unheated storage areas and workshops.

– Pollution degree 4

Continuous conductivity occurs, caused by conductive dust, rain or wetness.
For example: Devices in open-air plants and on construction machines.

Operating voltage (VDE: Rated voltage)

The level of a voltage that is specified by the manufacturer for a component, device or piece of equipment and to which the operating and performance parameters apply. The rated voltage depends on the connector's insulating material group and the respective creepage distances between the separate contacts, according to the specified pollution degree. By using empty modules and by differing the positioning of the contacts in the insulators, it is possible to influence the rated voltage considerably.

Devices are permitted to have more than one value for

the rated voltage or to have a range of rated voltages) (see table F.4 in DIN EN60664-1:2007).

Nominal voltage

A suitable rounded voltage level, which is specified for a device by the manufacturer for labeling or identification. In these explanations, the term nominal voltage is used for the value of the output voltage specified by the power company or the manufacturer of the voltage source for classification of the overvoltage category.

Rated impulse voltage

Value of the impulse test voltage that is specified by the manufacturer for a device or a part thereof and that indicates the defined staying power of its accompanying insulation against transient (short-term, lasting a few milliseconds) overvoltages. The impulse test voltage here is the highest level of the impulse voltage of a defined shape and polarity that is not permitted to lead to any insulation disruptive discharge under defined conditions.

The rated impulse voltage depends on the clearance distance between the separate contacts, according to the specified pollution degree. By using empty modules and by differing the positioning of the contacts in the insulators, it is possible to influence the rated impulse voltage considerably (see table F.2 in DIN EN60664-1:2007).

In the most recent version of DIN EN 60664-1:2009, resources that are not connected directly to the low voltage supply should be designed for the minimum clearance distance according to the possible continuous voltage, the temporary overvoltages or the periodic peak voltage (see table F.7 in DIN EN 60664-1:2007).

Impulse test voltage / power-frequency test voltage

Highest value of the impulse voltage of a defined shape and polarity that is not permitted to lead to any insulation disruptive discharge or sparkover under defined conditions.

Clearance distance

Shortest distance between two conductive parts, through the air.

Creepage distance

Shortest distance between two conductive parts, along the surface of an insulating material. The creepage distance is influenced by the pollution degree used.

Test voltage

The connector's electric strength is tested to the standard according to the specified rated impulse voltage by applying the test voltage (impulse test voltage or power-frequency test voltage according to table F.5) over a defined time period.

DIN EN 60664-1: Table F.5 – Test voltages for testing clearance distances at different altitudes
 (The voltage levels are valid only to verify the clearance distances)

Rated impulse voltage	Test impulse voltage		
	At sea level (NN)	at 200 m elevation	at 500 m elevation
\hat{u} kV	\hat{u} kV	\hat{u} kV	\hat{u} kV
0.33	0.357	0.355	0.350
0.5	0.541	0.537	0.531
0.8	0.934	0.920	0.899
1.5	1.751	1.725	1.685
2.5	2.920	2.874	2.808
4.0	4.923	4.874	4.675
6.0	7.385	7.236	7.013
8.0	9.847	9.648	9.950
12.0	14.770	14.471	14.025

Explanations of Voltage Information According to MIL

General information

The values according to SAE AS 13441 method 3001.1 correspond to those of MIL-Std 1344 method 3001. The specified values were determined in accordance with IEC 60512-2, Test 4a.

The inserts were each tested when inserted, whereby the test voltage was applied to the male insert.

All tests were conducted at normal room climate and are valid to an altitude of 2000 meters.

If there are deviations, the reduction factors according to the relevant standards should be taken into consideration.

Test voltage

The test voltage is defined as 75% of the disruptive discharge voltage established according to the standard.

Test voltage =

$$\text{Disruptive discharge voltage} \\ (\text{breakdown voltage}) \times 0.75$$

Operating voltage

According to the standard, 1/3 of the established test voltage is defined as the operating voltage.

Operating voltage =

$$\text{Disruptive discharge voltage} \\ (\text{breakdown voltage}) \times 0.75 \times 0.33$$

Please note

For some applications, the safety requirements for electric devices are very strict with regard to the operating voltage. In these cases, the operating voltage is defined according to the clearance and creepage distances between parts that are exposed. When making selections for these connectors, please contact us and inform us of the safety standard with which the product must comply.

Standards applied

SAE AS 13441-method 3001.1

MIL-Std 1344-method 3001

IEC 60512-2, Test 4a

Principles of Current Carrying Capacity

Derating measurement procedure (DIN EN 60512-5-2 : 2002)

Structure of the basis current carrying capacity curve

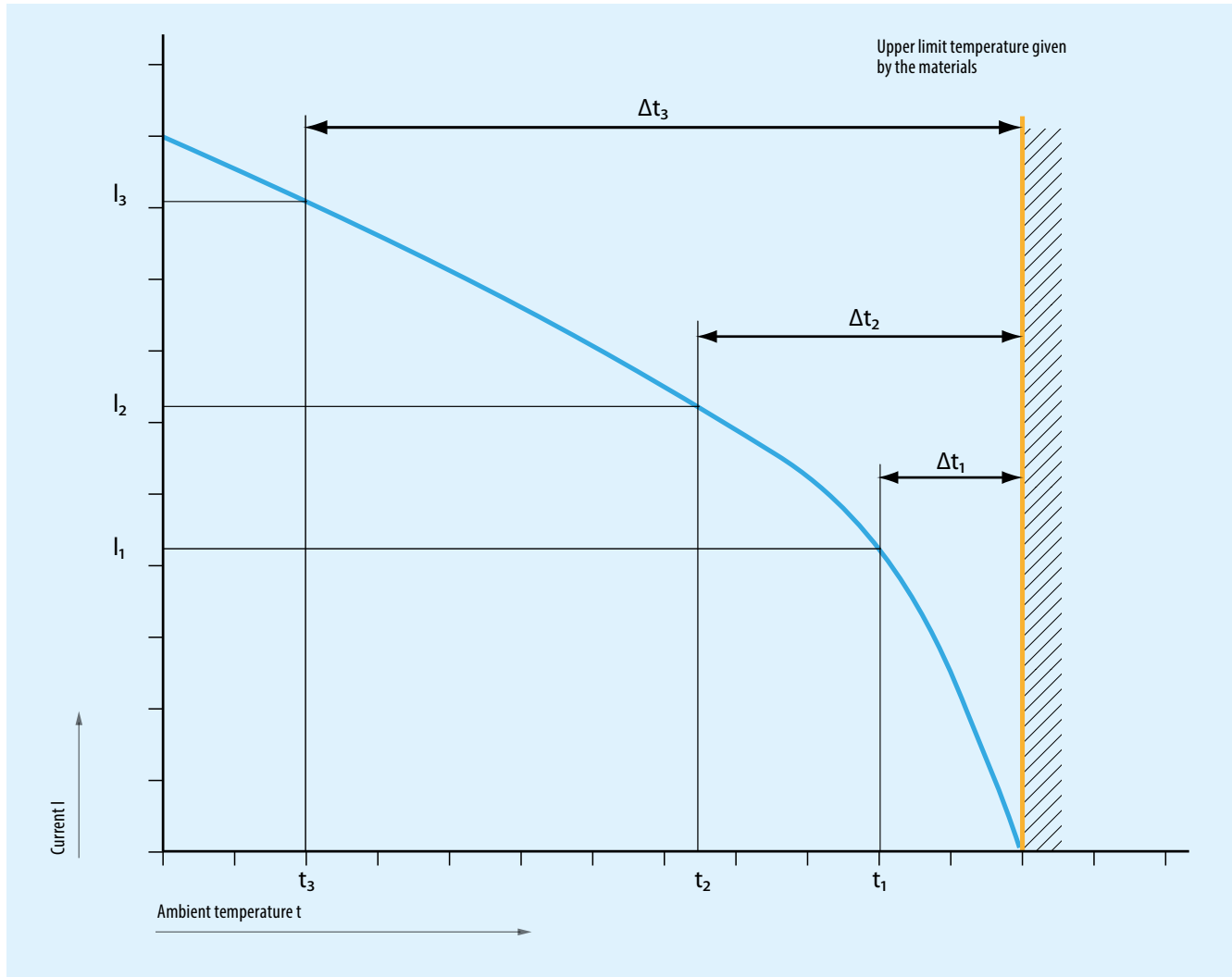

A connector's current carrying capacity is determined by measurement. It is determined by taking into account the self-heating due to Joule heat and the ambient temperature, and is limited by the thermal properties of the contact materials used; the upper limit temperatures of these materials should not be exceeded.

The relationship between current, the temperature increase caused as a result of the power dissipation at the contact resistor and the ambient temperature is depicted in a curve. The curve is drawn in a linear coordinate system with the current "I" as the ordinate and the temperature "t" as the abscissa. The upper limit temperature is used as a limit for the diagram.

In three measurements, the temperature rise due to Joule heat (Δt) is determined at different currents in at least three connectors and the points determined in this process are connected into a parabolic basis curve.

The corrected current carrying capacity curve (derating curve) can be derived from the basis curve. The safety factor ($0.8 \times I_n$) can be used to give consideration to such values as manufacturing tolerances as well as uncertainties in the temperature measurement and in the measurement setup.

Current Load

The heating in multi-position connectors and cables is greater than the heating in single contacts. A **reduction factor** is therefore used in the calculation. There is no direct regulation for connectors in this regard. For this reason, the reduction factors for multi-wire cables as given in DIN 57 298 Part 2 / VDE 0298 Part 2 are used. The reduction factor applies for 5 or more loaded wires (cf. also DIN 41 640, Part 3).

The nominal current is the current intensity that leads to a contact temperature increase of 45 K in a contact. Nominal current refers to individually loaded contacts.

Example

A cable with 24 wires (24 positions) is used. The nominal cross-section of a wire is 6 mm².

A reduction factor (e.g. cable laid in air) of 0.4 is to be applied for the load reduction depending on the number of loaded cable wires.

According to the current carrying capacity, a 6 mm² Cu line can be used for 44 amperes.

The 24 positions cable can accordingly be loaded with a max. 17.6 A/wire (0.4 × 44 A).

Technical information / application examples

Example: Termination cross-sections

The current load curve for the contact diameter 3 mm refers to a termination cross-section of 6 mm². If the contact (∅ 3 mm) is connected to a cable with a cross-section of 2.5 mm², the max. permissible current intensity is limited by the conductor. To determine the max. permissible current intensity, a smaller contact with corresponding cross-section is then selected.

Contact ∅ 3 mm with 6 mm²

= max. nominal single contact current load 50 A

Contact ∅ 3 mm with 2.5 mm² (with ∅ 2 mm)

= max. nominal single contact current load 40 A

Reduction factors

Multi-wire cable with the conductor cross-sections from 1.5 to 10 mm² when laid in air.

Cable in air

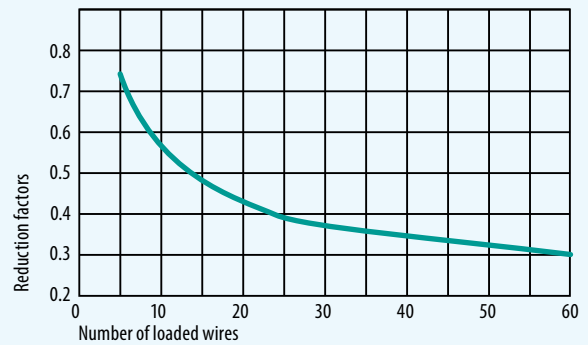

Load reduction factors

For plastic cable from 1.5 – 10 mm² when laid in air.

Number of loaded wires	Reduction factors
5	0.75
7	0.65
10	0.55
14	0.50
19	0.45
24	0.40
40	0.35
61	0.30

Current Carrying Capacity Diagram for Single Contact

Measurement made in accordance with DIN EN 60512-5-2 (derived basis curve shown = 0.8 × basis curve).

Upper limit temperature +120°C.

Termination with nominal cross-section.

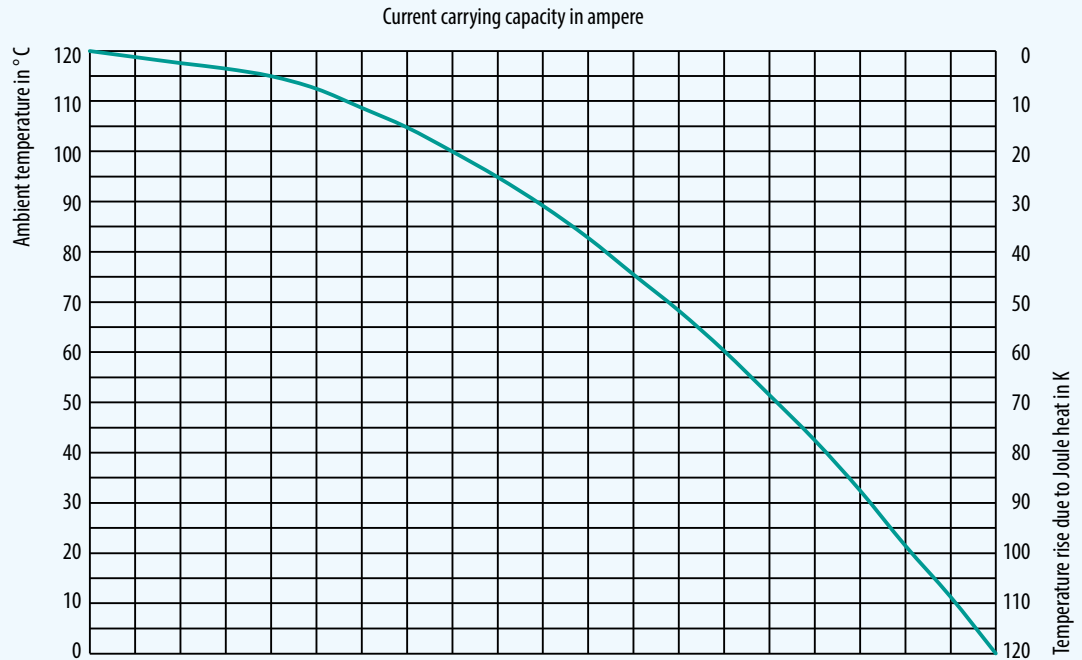

Contact Ø mm	Termination cross section	Contact type	0	1	2	3	4	5	6	7	8	9	10	
0.76	0.25 mm ²	ODU SPRINGTAC®	0	1	2	3	4	5	6	7	8	9	10	
	0.38 mm ²		0	1.5	2.5	3.5	5	6	7.5	8.5	9.5	11	12	
1.02	0.25 mm ²		0	1	2	3	4	5	6	7	8	9	10	
	0.5 mm ²		0	1.5	3	4.5	6	7.5	9	10.5	12	13.5	14.5	
1.5	0.25 mm ²		0	1	2	3	4	5	6	7	8	9	10	
	0.5 mm ²		0	1.5	3.5	5	6.5	8	10	11.5	13	15	16.5	
	1 mm ²		0	2.5	5	7.5	10	12.5	15	17.5	19.5	22.5	24.5	
	AWG16		0	3	6	9	12	15	18	21	24	27	29.5	
2.41	1.5 mm ²		0	3	6	9	12	15	18	21	24	27	29.5	
	2.5 mm ²		0	4	8	12	16	20	24	27.5	31.5	35.5	39	
	AWG12		0	4.5	9	13.5	18.5	23	28	32	36.5	41	45	
	0.5 mm ²		0	2	4	5.5	7.5	9.5	11.5	13	15	17	18.5	
3	1 mm ²		0	2.5	5.5	8	11	13.5	16.5	19	21.5	24.5	27	
	1.5 mm ²		0	3	6	9	12	15.5	19	22	25	28	31	
	2.5 mm ²		0	4	8	12	16	20	25	29	33	37	41	
	4 mm ²		0	6	13	19	25	32	39	45	51	58	64	
5	6 mm ²		0	6	13	19	25	32	39	45	51	58	64	
	4 mm ²		0	6	13	19	25	32	39	45	51	58	64	
	10 mm ²		0	11	21	32	42	53	65	75	85	97	106	
	16 mm ²		0	13	26	39	52	65	80	93	106	119	130	
8	16 mm ²		0	12.5	25	37	49	62	75	87	99	111	123	
	25 mm ²		0	18	36	52	68	84	100	114	128	142	155	
8	16 mm ²		0	15	29	44	59	74	90	104	118	133	147	
	25 mm ²		0	17	34	52	69	87	105	121	137	154	171	
10	25 mm ²	0	18	36	54	72	90	110	127	144	163	180		
	35 mm ²	0	20	39	59	79	99	120	139	158	179	196		
12	25 mm ²	0	19	38	57	75	95	115	133	152	172	188		
	35 mm ²	0	22	44	66	89	111	135	156	178	200	220		
	50 mm ²	0	24	48	72	96	120	145	170	195	220	240		
													Nominal current	Maximum continuous current

Technical Information

Measurement made in acc. with DIN EN 60512-5-2 (derived basis curve shown = 0.8 × basis curve).
Upper limit temperature +120°C. Termination with nominal cross-section.

Current Carrying Capacity Diagram for Fully Equipped Module

Measurement made in acc. with DIN EN 60512-5-2 (derived basis curve shown = 0.8 × basis curve).

Upper limit temperature +120°C.

Termination with nominal cross-section.

Values for 4 positions HV module correspond to values for 5 positions module

Values for 3 positions HV module correspond to values for 3 positions module

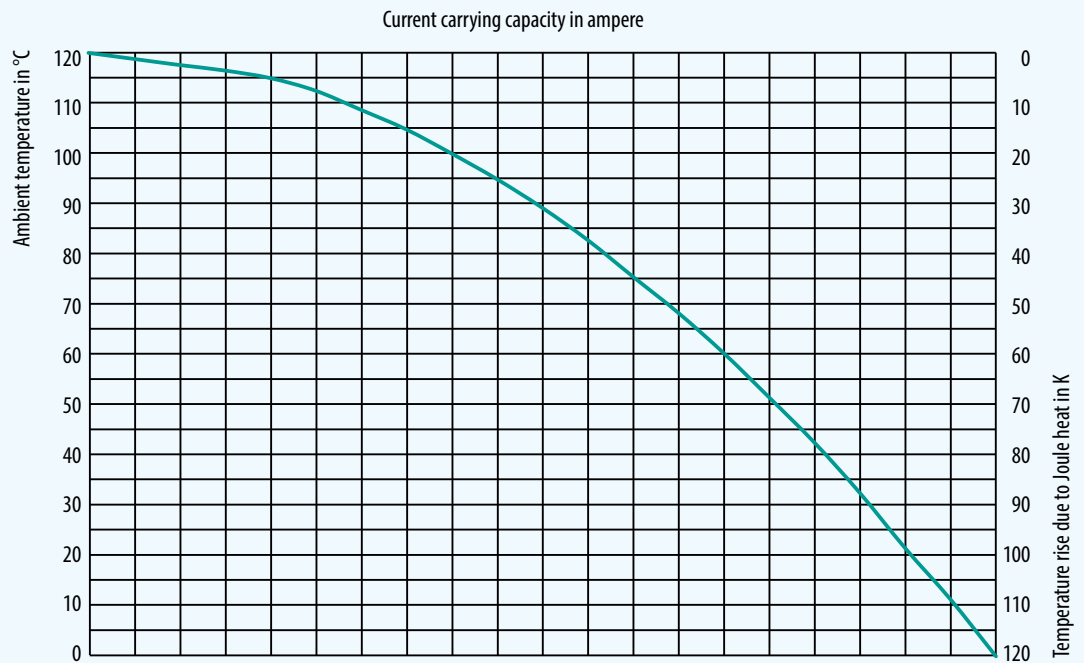

Module	Contact Ø mm	Termination cross section	Contact type	Current carrying capacity in ampere																		
10 pos.	0.76	0.25 mm ²	ODU SPRINGTAC®	0	1	2	3	3.5	4	5	6	7	8	8.5								
		0.38 mm ²		0	1	2	3	4	5	6	7	8	9	10								
6 pos.	1.02	0.25 mm ²		0	1	2	3	4	5	6	7.5	8.5	9.5	10.5								
		0.5 mm ²		0	1.5	3	4.5	6	7	8	9.5	11	12.5	14								
14 pos.	1.02	0.25 mm ²		0	1	2	3	3.5	4.5	5	6	7	8	9								
		0.5 mm ²		0	1.5	2.5	4	5	6	7	8.5	9.5	11	12								
5 pos.	1.5	0.25 mm ²		0	1	2	3	4	5	6	7.5	8.5	10	11								
		0.5 mm ²		0	1.5	2.5	4	5	6.5	8	9	10.5	11.5	13								
		1 mm ²		0	2	4.5	6.5	9	11	13	15	17.5	20	22								
		AWG 16		0	2.5	5	7.5	10	12.5	14.5	17.5	20	22.5	25								
4 pos.	2.41	1.5 mm ²		0	2.5	5	7.5	10	12.5	14.5	17.5	20	22.5	25								
		1 mm ²		0	1.5	3	4	5.5	7	8	9.5	11	12.5	14								
		1 mm ²		0	2.5	5	7	9	11	13	15.5	18	20.5	23								
		1.5 mm ²		0	2.5	5	7.5	10	12.5	15	18	21	24	27								
3 pos.	3	AWG 12		0	3.5	7	10	13	16	19	22.5	26	29.5	33								
		0.5 mm ²		0	4	8	12.5	16.5	20.5	25	29	33	37	41								
		1 mm ²	0	2	3.5	5	6.5	8	9.5	10.5	12	13	14.5									
		1 mm ²	0	2.5	5	7	9.5	12	14	16.5	19	21.5	24									
		1.5 mm ²	0	2.5	5.5	8	11	13.5	16	19	21.5	24.5	27									
2 pos.	5	2.5 mm ²	0	3.5	7	10.5	14	17.5	21	25	29	33	37									
		4 mm ²	0	5	10	15	20	25	30	35.5	41	46.5	52									
		6 mm ²	0	5	10	15	20	25	30	35.5	41	46.5	52									
		4 mm ²	0	5.5	11	17	22.5	28	34	39.5	45	50.5	56									
		10 mm ²	0	9.5	19	28	37.5	47	56.5	66	75	84.5	94									
2 pos.	8	16 mm ²	0	11.5	23	34.5	46	58	70	81	92	103	114									
		25 mm ²	0	11.5	23	34	46	58	70	81	92	103	114									
2 pos.	8	16 mm ²	0	16	32	48	64	79	95	111	128	144	160									
		25 mm ²	0	16	32	48	64	79	95	111	128	144	160									
2 pos.	8	16 mm ²	ODU	0	14	28	42	55.5	70	85	98	111	126	139								
		25 mm ²	LAMTAC®	0	16	33	49	65	82	100	116	132	149	164								
				Nominal current										Maximum continuous current								

Technical Information

Measurement made in accordance with DIN EN 60512-5-2 (derived basis curve shown = 0.8 × basis curve). Upper limit temperature +120°C. Termination with nominal cross-section.

Line Current Load

Laid	Exposed in air	Or on surfaces		
	Single-wire lines PVC, PE, PUR, TPE heat resistant	Multi-wire highly flexible lines for hand-held devices, wire/sheath cold-resistant, PVC insulated		Multi-wire movable lines standard program harmonized series
Number of loaded wires	1	2	3	2 or 3
Nominal cross-section of copper conductor in mm ²	Current load in A			
0.14	3			2
0.25	5			4
0.34	8			6
0.5	12	3	3	9
0.75	15	6	6	12
1	19	10	10	15
1.5	24	16	16	18
2.5	32	25	20	26
4	42			36
6	54			44
10	73			62
16	98			81
25	129			108
35	158			135
50	198			168
Current load according to	DIN VDE 0100 T.523 1981-06 group 3	following the principles of HD21S2T.1 based on H05VV-F VDE 0281		DIN VDE 0100T523 1981-06 group 2 DIN VDE 0298 T4 table 9

Permissible loads on insulated lines up to 30°C
Ambient temperature following the principles of
VDE 0100 part 523, 0298 part 4 and 0891 part 1.

Current load, flexible lines with nominal voltages up to
1,000V at ambient temperature +30°C.

International Protection (IP) Classes DIN EN 60529 (Respectively IEC 529 / VDE 0470T1)

Code letters (International Protection)		First code number (Protection against solid foreign bodies)		Second code number (Protection against water)			
IP		6		5			
Code number	Extent of protection		Code number	Extent of protection			
0	No protection		No protection against contact, no protection against solid foreign bodies	0	No protection against water	No protection against water	
1	Protection against large foreign bodies		Protection against large-surface contact with the back of the hand, protection against foreign bodies $\varnothing \geq 50$ mm	1	Protection against dripping water		Protection against vertically falling water drops
2	Protection against medium-sized foreign bodies		Protection against contact with the fingers, protection against foreign bodies. $\varnothing \geq 12$ mm	2	Protection against dripping water when tilted		Protection against falling water drops when tilted (any angle up to 15° from the vertical)
3	Protection against small foreign bodies		Protection against contact with tools, wires, or the like with $\varnothing \geq 2.5$ mm, protection against foreign bodies $\varnothing \geq 2.5$ mm	3	Protected against spraying water		Protection against water spraying at any angle up to 60° from the vertical
4	Protection against granular foreign bodies		The same as 3, except $\varnothing \geq 1$ mm	4	Protection against splashing water		Protection against splashing water from all directions
5	Protection against dust deposits		Protection against contact, protection against harmful dust deposit in the interior	5	Protection against water jet		Protection against water jet (nozzle) from any angle
6	Protection against dust ingress		Protection against foreign bodies $\varnothing \geq 1$ mm, protection against dust ingress	6	Protection against powerful water jet		Protection against powerful water jet from any angle
				7	Protection against immersion		Protection against water ingress during temporary immersion
				8	Protection against continuous immersion		Protection against pressurized water during continuous immersion
				9k¹	Protection against high pressure		Protection against water from high-pressure/ steam jet cleaners.

¹ IP x9k is not included in EN 60529 or IEC 60529, but is included in DIN 40 050-9.

AWG – Cross-Section Conversions (AWG = American Wire Gauge)

The AWG system describes the cross section of a wire using a gauge number for every 26% increase in conductor cross section. As the wire diameter increases, the AWG gauge number decreases; as the wire size decreases, the AWG gauge number increases.

This is only valid for solid conductors.

Most wires are made with **stranded conductors**. Compared to solid conductors stranded wires offer higher durability, higher flexibility and better performance under bending and vibration.

Stranded wires are made from wires with smaller gauge sizes (higher AWG gauge number). The AWG gauge number of the stranded wire is equal to that of a solid conductor of the same size wire. The cross section of the stranded conductor is the sum of cross sections of the single conductors.

For example, a AWG-20 stranded wire of 7 AWG-28 conductors has a cross section of 0.563 mm²; an AWG-20 stranded wire with 19 AWG-32 conductors has a cross section of 0.616 mm².

Conversion table AWG/mm²

AWG	Circular wire				
	Diameter		Cross section mm ²	Weight kg/km	Max. resistance Ω/km
	Inch	mm			
10 (1)	0.1020	2.5900	5.2700	47.000	3.45
10 (37/26)	1.1090	2.7500	4.5300	43.600	4.13
12 (1)	0.0808	2.0500	3.3100	29.500	5.45
12 (19/25)	0.0895	2.2500	3.0800	28.600	6.14
12 (37/28)	0.0858	2.1800	2.9700	26.300	6.36
14 (1)	0.0641	1.6300	2.0800	18.500	8.79
14 (19/27)	0.0670	1.7000	1.9400	18.000	9.94
14 (37/30)	0.0673	1.7100	1.8700	17.400	10.50
16 (1)	0.0508	1.2900	1.3100	11.600	13.94
16 (19/29)	0.0551	1.4000	1.2300	11.000	15.70
18 (1)	0.0403	1.0200	0.8200	7.320	22.18
18 (19/30)	0.0480	1.2200	0.9600	8.840	20.40
20 (1)	0.0320	0.8130	0.5200	4.610	35.10
20 (7/28)	0.0366	0.9300	0.5600	5.150	34.10
20 (19/32)	0.0384	0.9800	0.6200	5.450	32.00
22 (1)	0.0252	0.6400	0.3240	2.890	57.70
22 (7/30)	0.0288	0.7310	0.3540	3.240	54.80
22 (19/34)	0.0307	0.7800	0.3820	3.410	51.80
24 (1)	0.0197	0.5000	0.1960	1.830	91.20
24 (7/32)	0.0230	0.5850	0.2270	2.080	86.00
24 (19/36)	0.0252	0.6400	0.2400	2.160	83.30
26 (1)	0.1570	0.4000	0.1220	1.140	147.00
26 (7/34)	0.0189	0.4800	0.1400	1.290	140.00
26 (19/38)	0.0192	0.4870	0.1500	1.400	131.00
28 (1)	0.0126	0.3200	0.0800	0.716	231.00
28 (7/36)	0.0150	0.3810	0.0890	0.813	224.00
28 (19/40)	0.0151	0.3850	0.0950	0.931	207.00
30 (1)	0.0098	0.2500	0.0506	0.451	374.00
30 (7/38)	0.0115	0.2930	0.0550	0.519	354.00
30 (19/42)	0.0123	0.3120	0.0720	0.622	310.00
32 (1)	0.0080	0.2030	0.0320	0.289	561.00
32 (7/40)	0.0094	0.2400	0.0350	0.340	597.10
32 (19/44)	0.0100	0.2540	0.0440	0.356	492.00
34 (1)	0.0063	0.1600	0.0201	0.179	951.00
34 (7/42)	0.0083	0.2110	0.0266	0.113	1,491.00
36 (1)	0.0050	0.1270	0.0127	0.072	1,519.00
36 (7/44)	0.0064	0.1630	0.0161	0.130	1,322.00
38 (1)	0.0040	0.1000	0.0078	0.072	2,402.00
40 (1)	0.0031	0.0800	0.0050	0.043	3,878.60
42 (1)	0.0028	0.0700	0.0038	0.028	5,964.00
44 (1)	0.0021	0.0540	0.0023	0.018	8,660.00

Source: Gore & Associates, Pleinfeld

Technical Terms / Definitions / Information

AWG

See page [128](#).

Basis curve

Metrologically determined current carrying capacity curve for connectors according to the measurement method described in DIN EN 60512-5-2:2002, depending on the permissible limit temperature of the materials.

Crimping

Termination technology in which a non-detachable, solderless, electrical and mechanical connection is produced by means of compressive deformation or compressive forming of the termination sleeve around the conductor.

Current carrying capacity (nominal current and maximum continuous current)

The information refers to sufficiently dimensioned connection cable in accordance with DIN VDE 0295 (DIN EN 60228) in class 5, so that no stronger temperature increase is caused from this source. The specified temperature increase takes place through the contact. The information provided refers to average values.

Derating curve

The corrected current carrying capacity curve, derived from the determined basis curve ($0.8 \times I_n$). It takes into account manufacturing tolerances as well as uncertainties in the temperature measurement and the measurement setup.

Derating measurement procedure (DIN EN 60512-5-2)

Measurement method for determining the current carrying capacity of connectors while taking into account the maximum permissible limit temperature.

Mating or demating force

For lamella contacts, the information refers to lubricated contacts (condition at delivery) and after approximately 30 mating cycles. The forces are higher for new contacts (lubricated).

For springwire contacts, the information refers to unlubricated contacts (condition at delivery) and new contacts. The information refers to silver-plated surfaces. The provided values are averages with a possible deviation of $\pm 50\%$.

Limit temperature

The highest temperature at which a connector is permitted to be operated. It includes the contact heating due to the current carrying capacity. For contacts with standard springwires, it amounts to $+120^\circ\text{C}$ and for contacts with standard lamella it is $+140^\circ\text{C}$.

[For high temperature applications up to \$500^\circ\text{C}\$ and higher, please contact ODU.](#)

Lubrication

All standard contacts are lubricated at the factory. For re-application of lubricant, we recommend the ODU maintenance kit (see page [116](#)).

Materials (standard model)

Pins and carriers of the sockets are manufactured from CuZn alloy and are silver-plated. The lamellas are made of CuBe alloy and are likewise silver-plated. The wires of the springwire contacts are made of CuSn alloy and are also silver-plated.

Mating cycles

Mechanical activation of connectors and plugging devices by means of insertion and withdrawal (mating and demating).

A mating cycle consists of one insertion and one withdrawal. The standard value for lamella contacts is 10,000 mating cycles, for ribbon cable connectors 50,000 mating cycles and for springwire contacts 100,000 mating cycles.

These figures are valid only under the following conditions:

- Clean environment,
- Suitable radial guide,
- Flawless counterpins.

Maximum continuous current

The metrologically determined current intensity at room temperature (approx. 20°C) that leads to an increase in the contact temperature to the limit temperature.

Nominal current

The metrologically determined current intensity that leads to an increase of 45 Kelvin in the contact temperature. The nominal current is determined according to the derating measurement procedure (DIN EN 60512-5-2:2002) and is derived from the basis curve.

Technical Terms / Definitions / Information

Soldered connections

Termination technology in which a melted added metal (solder), whose melting temperature is less than that of the base metals to be connected, is used to join two metallic materials.

Impulse current

One-time power pulse current with a load period of 10 ms.

Termination cross-section

The specified cross-sections correspond to DIN VDE 0295 (DIN EN 60228) Class 5.

Termination techniques

Methods for the termination of lines at the electromechanical components, for example, solderless connections in accordance with DIN EN 60352: crimped, press-in connection etc. or soldered connection.

Volume resistance

Total resistance from termination to termination. The contact resistance here is considerably less than the volume resistance. The values given are average values.

Suitable safety precautions must be taken in order to ensure that personnel do not come into contact with live conductors during installation and operation. All entries were reviewed with maximum care before this catalogue was printed.

ODU reserves the right to make changes in accordance with the current state of the art without advance notice, and without being obligated to provide replacement deliveries or to continue production of older designs.

Company Information



Quality Management

ODU has had a powerful quality management system in place for years. ODU has been successfully certified to ISO 9001 since 1994. In addition, the automotive sector of the company group is certified to ISO TS 16949. The certification process was carried out by the internationally active BVQI (Bureau Veritas Quality International) company.

ODU is also certified according to the medical standard ISO 13485:2003 + AC:2007.

Additional to this ODU is certificated to DIN EN ISO 14001:2009 as well as to different certifications: VDE, UL, UL wiring harness, SCA, VG, MIL.



Your Partner in Many Application Areas



ODU stands for quality, flexibility and reliability. This is why customers working in many application areas rely on ODU products in markets such as the following:

- Medical
- Industrial
- Measuring and testing
- Military and security
- Energy
- Automotive.



The Complete ODU Product Range

<p>Single contacts (round or flat)</p>			
<p>High current connectors</p>			
<p>Circular connectors with Push-Pull locking</p>			
<p>Modular rectangular connectors</p>			
<p>PCB connectors</p>			
<p>Robust connectors</p>			
<p>Disposable Systems</p>			
<p>Application specific solutions</p>			
<p>AMC – Advanced Military Connector</p>			
<p>Cable assembly</p>			

Everything From One Source

Each connection needs its individual cable. Make no compromises when it comes to the quality of the complete connection system. ODU gives you the complete system solution from one source, with no intermediary suppliers.

Cable assembly is a very complex subject. It requires equal measures of expertise in the areas of connectors, cables and assembly. ODU meets all these requirements in full.

Our competent assembly team tests the complete system according to your specifications. Our assembly service promises you the same quality found in our connectors – without compromises.

ODU offers you all from one source

- 100 % final inspections
- Production in clean room acc. to EN ISO14644-1 possible
- Automatic processes (cutting, stripping, attaching)
- Extrusion possible with a hot-melt and high pressure/temperature process
- Ultrasound welding
- EMC-compatible assembly
- Application specific labeling
- Widest range of potting possibilities for sealed systems
- Extruded cable crossovers.

Advantages for the customer

- Modern manufacturing facilities in Mühldorf (Germany), Shanghai (China) and Sibiu (Romania)
- Reliability thanks to our company-wide quality strategy
- Products with durability and functional reliability
- Production according to UL (file: E333666) possible
- Inspections, such as crimp force monitoring, during production.



Application Specific Connectors



Innovative, dynamic markets call for innovative connectors.

“As an expert for special applications and requirements, we develop forward-looking, appropriate connectors attuned to your needs!”

In spite of the global trend toward standardized connectors, there are always applications that call for an application specific solution. We accept this challenge and

develop innovative products for our customers based on our many years of extensive know-how, our creativity and, not least, our high level of vertical integration. Technology access and technology mastery, combined with intensive cooperation with the user, form the basis for achieving success together.

Design-to-cost is joined by design-for-application for the customer's benefit.

Order Information



Module Overview

for ODU-MAC in the DIN housing and ODU-MAC in the aluminium frame

Description	Units	Page	Module number	Description	Units	Page	Module number
10 positions for turned contacts	1	20	1	2 positions for 75 Ω coaxial contacts	5	56	19
10 positions for stamped contacts	1	22	2	Module for 2 compressed air valves	5	58	20
6 positions for turned contacts	2	24	3	Module for 1 compressed air valve	8	60	21
14 positions for turned contacts	3	26	4	Module for 2 compressed air valves	16	60	22
5 positions for turned contacts	2	28	5	Module for fluid coupling plug	5	62	23
4 positions for turned contacts	3	30	6	2 positions fibre-optic contacts for plastic fibre	5	66	24
3 positions for turned contacts	3	32	7	5 positions fibre-optic contacts for plastic fibre	2	68	25
2 positions for turned contacts	5	34	8	3 positions fibre-optic contacts for fibre-glass	4	70	26
4 positions high voltage module with turned contacts	3	36	9	Module for multi-position, shielded implementation, insert size 0	5	72	27
3 positions power module with turned contacts	4	38	10	Module for multi-position, shielded implementation, insert size 1	6	74	28
2 positions power module ODU LAMTAC® with turned contacts	6	40	11	Module for multi-position, shielded implementation, insert size 2	7	76	29
2 positions power contacts ODU SPRINGTAC® with turned contacts	6	42	12	Module for multi-position, shielded implementation, insert size 3	8	78	30
1 position power contact ODU LAMTAC®	7	44	13	Empty modules	1, 3, 5	80	31
1 position for high voltage contacts	8	46	14	Coding modules	1	81	32
4 positions for 50 Ω coaxial contacts non-magnetic	3	48	15	Pin protection modules	1	82	33
2 positions for 50 Ω coaxial contacts	5	50	16				
2 positions for 50 Ω coaxial contacts SMA termination	5	52	17				
2 positions for 50 Ω coaxial contacts high voltage, non-magnetic	5	54	18				

Frame sizes ODU-MAC in the DIN housing

Please set up an ODU-MAC in a **DIN housing** according to your specifications with the help of the module numbers and the depictions.

Size 1
10 units

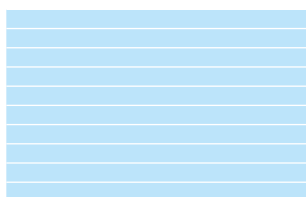

Size 2
16 units



Size 3
24 units

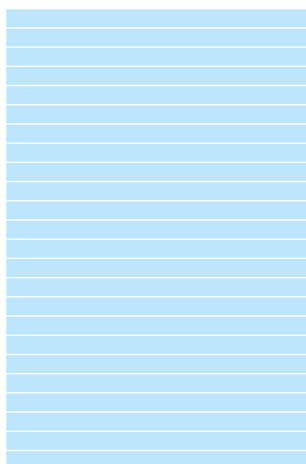

Size 4
34 units

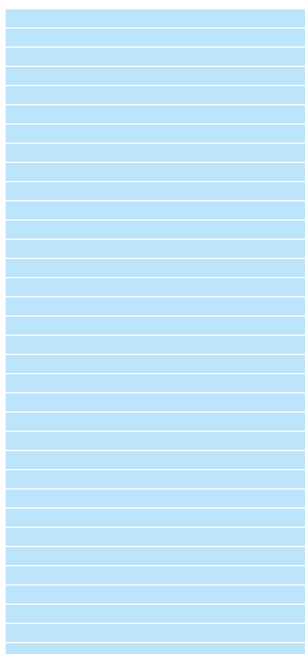

Pitch: 2.54 mm = 1 unit

Frame sizes ODU-MAC in the aluminium frame

Please set up an ODU-MAC in an **aluminium frame** according to your specifications with the help of the module numbers and the depictions.

Max. 60 units

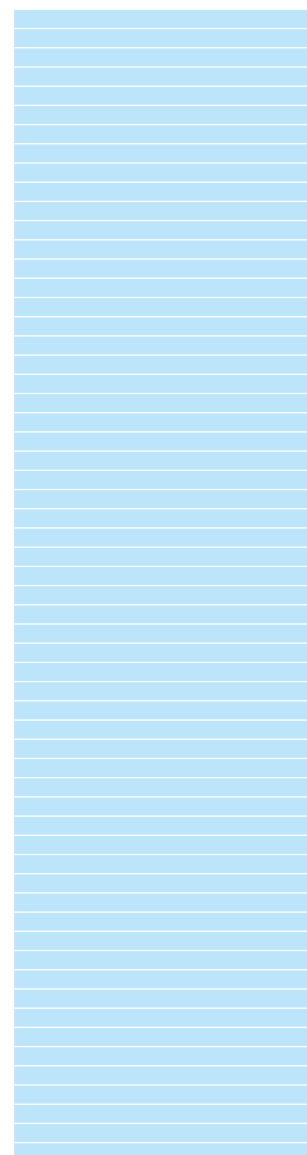

Pitch: 2.54 mm = 1 unit

