



### POWER SUPPLY

- 3AC 380-480V Wide-range Input
- Width only 110mm
- Efficiency up to 95.3%
- Excellent Partial Load Efficiency
- 150% (1440W) Peak Load Capability
- Easy Fuse Tripping due to High Overload Current
- Active Power Factor Correction (PFC)
- Active Filtering of Input Transients
- Minimal Inrush Current Surge
- Three Input Fuses Included
- Current Sharing Feature for Parallel Use
- Full Power Between -25°C and +60°C
- DC-OK Relay Contact
- Shut-down Input
- 3 Year Warranty

### GENERAL DESCRIPTION

The most outstanding features of the DIMENSION Q-Series DIN-rail power supplies are the extremely high efficiencies and the small sizes, which are achieved by a synchronous rectification and other technological designs.

Large power reserves of 150% support the starting of heavy loads such as DC-motors or capacitive loads. In many cases this allows the use of a unit from a lower wattage class which saves space and money.

High immunity to transients and power surges as well as low electromagnetic emission makes usage in nearly every environment possible.

The integrated output power manager, the three input fuses and near zero input inrush current make installation and usage simple. Diagnostics are easy due to the DC-ok relay, a green DC-OK LED and the red overload LED.

A large international approval package for a variety of applications makes this unit suitable for nearly every application.

### SHORT-FORM DATA

Output voltage	DC 48V	
Adjustment range	48 - 54V	
Output current	20 – 17.8A	continuous
	30 – 26.7A	for typ. 4s
Output power	960W	continuous
	1440W	for typ. 4s
Output ripple	< 150mVpp	20Hz to 20MHz
Input voltage	3AC 380-480V	-15%/+20%
Mains frequency	50-60Hz	±6%
AC Input current	1.65 / 1.35A	at 3x400 / 480Vac
Power factor	0.88 / 0.90	at 3x400 / 480Vac
AC Inrush current	typ. 4.5A peak	
Efficiency	95.4 / 95.2%	at 3x400 / 480Vac
Losses	46.3 / 48.4W	at 3x400 / 480Vac
Temperature range	-25°C to +70°C	operational
Derating	24W/°C	+60 to +70°C
Hold-up time	typ. 25 / 25ms	at 3x400 / 480Vac
Dimensions	110x124x127mm WxHxD	

### ORDER NUMBERS

Power Supply	<b>QT40.481</b>	48-54V Standard unit
Accessory	ZM2.WALL	Wall mount bracket
	UF20.481	Buffer unit

### MARKINGS



Marine, pending



EMC, LVD

### INDEX

	Page		Page
1. Intended Use .....	3	21. Fulfilled Standards.....	17
2. Installation Requirements.....	3	22. Used Substances .....	18
3. AC-Input.....	4	23. Physical Dimensions and Weight .....	18
4. DC-Input.....	5	24. Accessories .....	19
5. Input Inrush Current .....	5	25. Application Notes.....	20
6. Output .....	6	25.1. Repetitive Pulse Loading.....	20
7. Hold-up Time.....	8	25.2. Peak Current Capability .....	21
8. DC-OK Relay Contact .....	9	25.3. Back-feeding Loads .....	21
9. Shut-down Input .....	9	25.4. External Input Protection.....	21
10. Efficiency and Power Losses.....	10	25.5. Charging of Batteries .....	22
11. Reliability.....	11	25.6. Output Circuit Breakers.....	22
12. Front Side and User Elements.....	12	25.7. Using only 2 Legs of a 3-Phase System .....	23
13. Functional Diagram.....	13	25.8. Parallel Use to Increase Output Power....	24
14. Terminals and Wiring.....	13	25.9. Parallel Use for Redundancy .....	24
15. EMC.....	14	25.10. Daisy Chaining of Outputs .....	25
16. Environment.....	15	25.11. Series Operation .....	25
17. Protection Features .....	16	25.12. Inductive and Capacitive Loads.....	25
18. Safety Features .....	16	25.13. Use in a Tightly Sealed Enclosure .....	25
19. Dielectric Strength .....	16	25.14. Mounting Orientations .....	26
20. Approvals.....	17		

The information presented in this document is believed to be accurate and reliable and may change without notice. No part of this document may be reproduced or utilized in any form without permission in writing from the publisher.

### TERMINOLOGY AND ABBREVIATIONS

<b>PE and <math>\oplus</math> symbol</b>	PE is the abbreviation for <b>Protective Earth</b> and has the same meaning as the symbol $\oplus$ .
<b>Earth, Ground</b>	This document uses the term "earth" which is the same as the U.S. term "ground".
<b>T.b.d.</b>	To be defined, value or description will follow later.
<b>AC 400V</b>	A figure displayed with the AC or DC before the value represents a nominal voltage with standard tolerances (usually $\pm 15\%$ ) included. E.g.: DC 12V describes a 12V battery disregarding whether it is full (13.7V) or flat (10V)
<b>400Vac</b>	A figure with the unit (Vac) at the end is a momentary figure without any additional tolerances included.
<b>50Hz vs. 60Hz</b>	As long as not otherwise stated, AC 380V and AC 400V parameters are valid at 50Hz and AC 480V parameters are valid at 60Hz mains frequency.

### 1. INTENDED USE

This device is designed for installation in an enclosure and is intended for the general use such as in industrial control, office, communication, and instrumentation equipment.

Do not use this power supply in aircraft, trains and nuclear equipment where malfunction may cause severe personal injury or threaten human life.

### 2. INSTALLATION REQUIREMENTS

This device may only be installed and put into operation by qualified personnel.

This device does not contain serviceable parts. The tripping of an internal fuse is caused by an internal defect.

If damage or malfunction should occur during installation or operation, immediately turn power off and send unit to the factory for inspection.

Mount the unit on a DIN-rail so that the output and input terminals are located on the bottom of the unit. For other mounting orientations see de-rating requirements in this document. See chapter 25.14.

This device is designed for convection cooling and does not require an external fan. Do not obstruct airflow and do not cover ventilation grid (e.g. cable conduits) by more than 30%!

Keep the following installation clearances: 40mm on top, 20mm on the bottom, 5mm on the left and right sides are recommended when the device is loaded permanently with more than 50% of the rated power. Increase this clearance to 15mm in case the adjacent device is a heat source (e.g. another power supply).

**⚠ WARNING** Risk of electrical shock, fire, personal injury or death.

- Do not use the power supply without proper grounding (Protective Earth). Use the terminal on the input block for earth connection and not one of the screws on the housing.
- Turn power off before working on the device. Protect against inadvertent re-powering.
- Make sure that the wiring is correct by following all local and national codes.
- Do not modify or repair the unit.
- Do not open the unit as high voltages are present inside.
- Use caution to prevent any foreign objects from entering the housing.
- Do not use in wet locations or in areas where moisture or condensation can be expected.
- Do not touch during power-on, and immediately after power-off. Hot surfaces may cause burns.

### 3. AC-INPUT

AC input	nom.	3AC 380-480V	TN, TT, IT-mains networks, grounding of one phase is allowed except in UL 508 applications
AC input range	min.	3x 323-576Vac	continuous operation
Allowed Voltage Phase to Earth		500Vac	IEC 60664-1
Input frequency	nom.	50-60Hz	±6%
Turn-on voltage	typ.	3x 305Vac	steady-state value, see Fig. 3-1
Shut-down voltage	typ.	3x 275Vac	steady-state value, see Fig. 3-1

		3AC 400V	3AC 480V	
Input current	typ.	1.65A	1.35A	at 48V, 20A, symmetrical phase voltage, see Fig. 3-3
Power factor *)	typ.	0.88	0.90	at 48V, 20A, see Fig. 3-4
Start-up delay	typ.	500ms	600ms	see Fig. 3-2
Rise time	typ.	30ms	30ms	0mF, 48V, 20A, see Fig. 3-2
	typ.	40ms	40ms	20mF, 48V, 20A, see Fig. 3-2
Turn-on overshoot	max.	1V	1V	see Fig. 3-2

\*) The power factor is the ratio of the true (or real) power to the apparent power in an AC circuit.

Fig. 3-1 Input voltage range

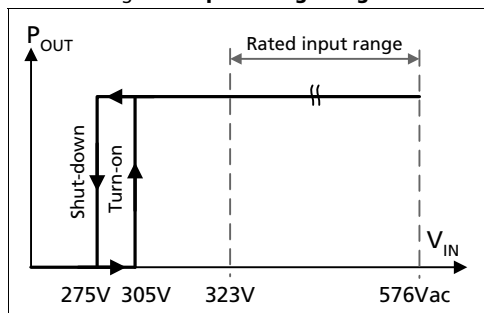


Fig. 3-2 Turn-on behavior, definitions

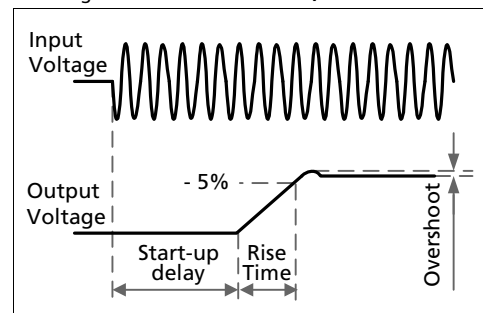


Fig. 3-3 Input current vs. output load at 24V

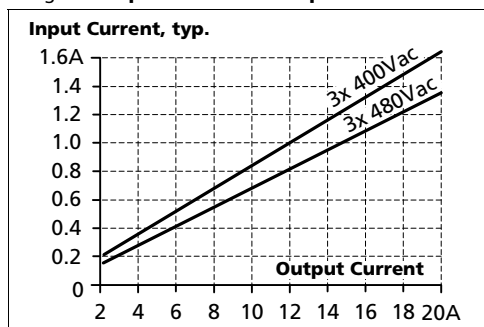
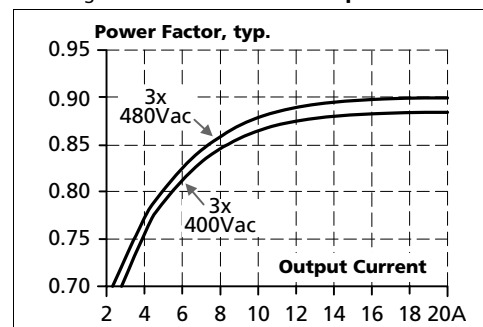


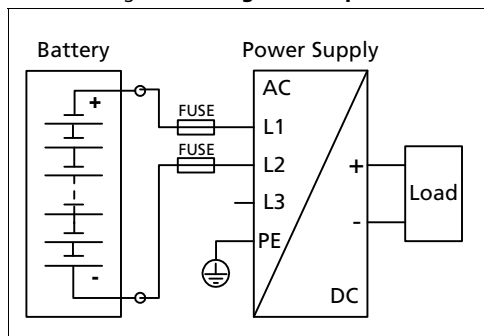
Fig. 3-4 Power factor vs. output load



### 4. DC-INPUT

DC input	nom.	<b>DC 600V</b>	
DC input range	min.	450-800Vdc	continuous operation
Allowed Voltage Line to Earth	max.	820Vdc	IEC 60664-1
DC input current	typ.	2.3A / 1.3A	450Vdc / 800Vdc, at 48V, 20A
Turn-on voltage	typ.	425Vdc	steady state value
Shut-down voltage	typ.	375Vdc	steady state value

Fig. 4-1 Wiring for DC Input



#### Instructions for DC use:

- Use a battery or similar DC source. For other sources contact PULS
- Connect +pole to L1 and -pole to L2.
- Terminal L3 remains unused, terminal screw of L3 must be securely tightened.
- Use appropriate external fuses in the + and - lines which are suitable for the DC-voltage.
- Connect the PE terminal to a earth wire or to the machine ground.
- DC-operation is not included in the UL approval. Additional testing might be necessary.

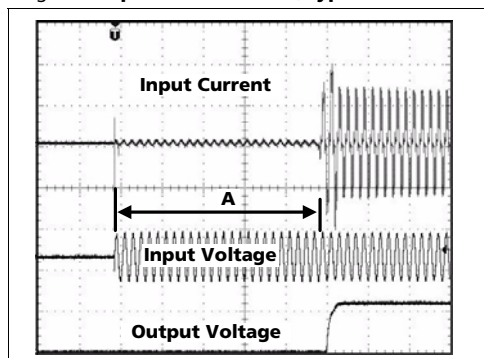
### 5. INPUT INRUSH CURRENT

An active inrush limitation circuit limits the input inrush current after turn-on of the input voltage and after short input voltage interruptions.

The charging current into EMI suppression capacitors is disregarded in the first microseconds after switch-on.

		<b>3AC 400V</b>	<b>3AC 480V</b>	
Inrush current	max.	6A <sub>peak</sub>	6A <sub>peak</sub>	-25°C to +70°C
	typ.	4.5A <sub>peak</sub>	4.5A <sub>peak</sub>	-25°C to +70°C
Inrush energy	max.	1.5A <sup>2</sup> s	1.5A <sup>2</sup> s	-25°C to +70°C
Inrush delay (A)	typ.	500ms	600ms	

Fig. 5-1 Input inrush current, typical behavior



- A Inrush delay
- Input: 3x 400Vac
- Output: 48V, 20A
- Ambient: 25°C
- Upper curve: Input current 2A / DIV
- Middle curve: Input voltage 1000V / DIV
- Lower curve: Output voltage 40V / DIV
- Time basis: 100ms / DIV

### 6. OUTPUT

Output voltage	nom.	48V	
Adjustment range	min.	48-54V	guaranteed
	max.	58V	at clockwise end position of potentiometer
Factory setting	typ.	48.0V	±0.2%, at full load, cold unit, in "single use" mode
	typ.	46.0V	±0.2%, at full load, cold unit, in "parallel use" mode
	typ.	48.0V	at no load, cold unit, in "parallel use" mode
Line regulation	max.	10mV	3x 323-576Vac
Load regulation	max.	50mV	in "single use" mode: static value, 0A → 20A, see Fig. 6-1
	typ.	2000mV	in "parallel use" mode: static value, 0A → 20A, see Fig. 6-2
Ripple and noise voltage	max.	150mVpp	20Hz to 20MHz, 50Ohm
Output capacitance	typ.	3 660µF	

#### Continuous output current and output power

Output current	nom.	20A	at 48V, see Fig. 6-1 and Fig. 6-2
	nom.	17.8A	at 54V, see Fig. 6-1 and Fig. 6-2
Output power	nom.	960W	
Short-circuit current	min.	20A	load impedance 50mOhm, see Fig. 6-1 and Fig. 6-2
	max.	22A	load impedance 50mOhm, see Fig. 6-1 and Fig. 6-2

#### Short term output current and output (BonusPower®)

The power supply is designed to support loads with a higher short-term power requirement without damage or shutdown. The short-term duration is hardware controlled by an output power manager. The BonusPower® is available on a repeated basis. Detailed information can be found in chapter 25.1.

Once BonusPower® has been suspended by the output power limiter, a timer disables the next BonusPower® capability. The recovery timer will start as soon as the output voltage reaches the adjusted value again, which usually happens after the load has been reduced.

Output current	nom.	30A	at 48V, see Fig. 6-1 and Fig. 6-2
	nom.	26.7A	at 54V, see Fig. 6-1 and Fig. 6-2
Output power	nom.	1440W	BonusPower®
Short-circuit current	min.	30A	load impedance 50mOhm, see Fig. 6-1 and Fig. 6-2
	max.	34A	discharge current of output capacitors not included
BonusPower® time	typ.	4s	at 48V, 30A
	min.	3.5s	duration until the output voltage dips
	max.	4.5s	see Fig. 6-3
BonusPower® recovery time	typ.	7s	Overload free time to reset power manager, see Fig. 6-4

#### Peak current capability (up to several milliseconds)

The power supply can deliver a peak current which is higher than the specified short term current. This helps to start current demanding loads or to safely operate subsequent circuit breakers.

The extra current is supplied by the output capacitors inside the power supply. During this event, the capacitors will be discharged and causes a voltage dip on the output. Detailed curves can be found in chapter 25.2.

Peak current voltage dips	typ.	from 48V to 39V	at 40A for 50ms, resistive load
	typ.	from 48V to 26V	at 100A for 2ms, resistive load
	typ.	from 48V to 18V	at 100A for 5ms, resistive load

Fig. 6-1 Output voltage vs. output current in "single use" mode, typ.

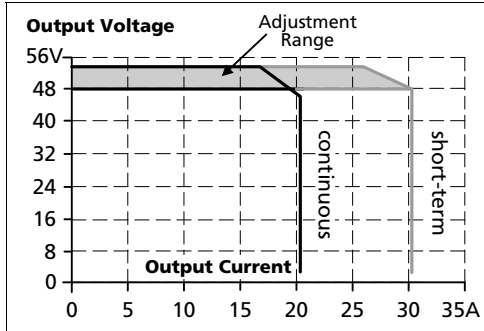


Fig. 6-2 Output voltage vs. output current in "parallel use" mode, typ.

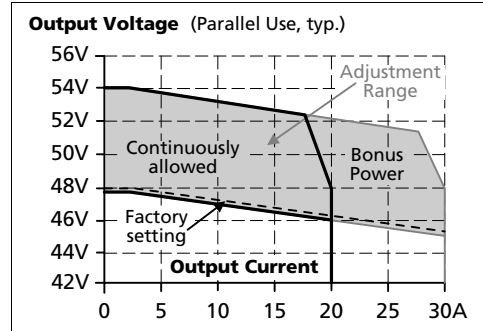


Fig. 6-3 Bonus time vs. output power

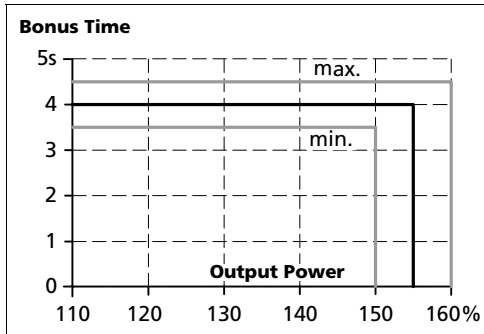
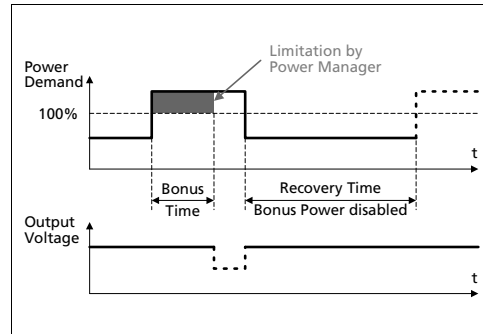
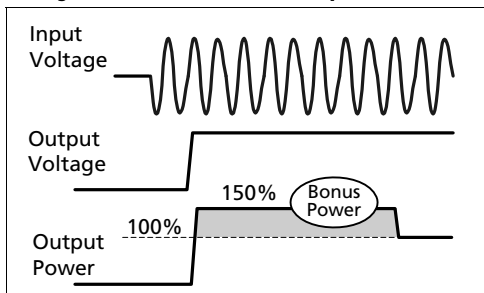


Fig. 6-4 BonusPower® recovery time



The BonusPower® is available as soon as power comes on.

Fig. 6-5 BonusPower® after input turn-on



### 7. HOLD-UP TIME

		3AC 400V	3AC 480V	
Hold-up Time	typ.	25ms	25ms	at 48V, 20A, see Fig. 7-1
	typ.	50ms	50ms	at 48V, 10A, see Fig. 7-1

The hold-up times for an operation on only two legs of a three phase system differ, curves can be found in chapter 25.7.

Fig. 7-1 Hold-up time vs. input voltage

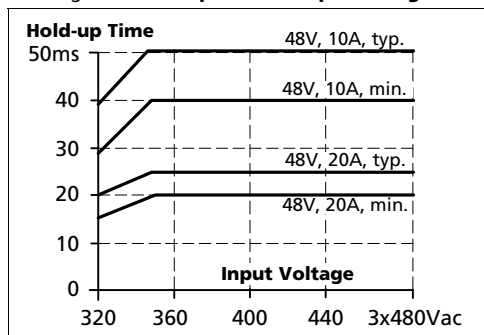
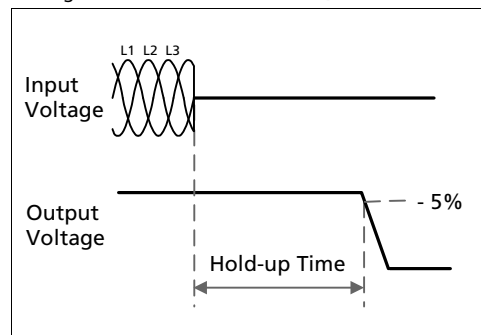


Fig. 7-2 Shut-down behavior, definitions



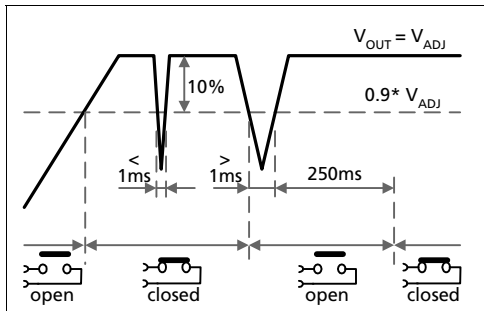


### 8. DC-OK RELAY CONTACT

This feature monitors the output voltage, which is produced by the power supply itself. It is independent of a back-fed voltage from a unit connected in parallel to the power supply output.

Contact closes	As soon as the output voltage reaches 90% of the adjusted output voltage.		
Contact opens	As soon as the output voltage dips more than 10% below the adjusted output voltage. Short dips will be extended to a signal length of 250ms. Dips shorter than 1ms will be ignored.		
Contact re-closes	As soon as the output voltage exceeds 90% of the adjusted voltage.		
Contact ratings	max	60Vdc 0.3A, 30Vdc 1A, 30Vac 0.5A	resistive load
	min	1mA at 5Vdc	min. permissible load
Isolation voltage	See dielectric strength table in section 19.		

Fig. 8-1 DC-ok relay contact behavior



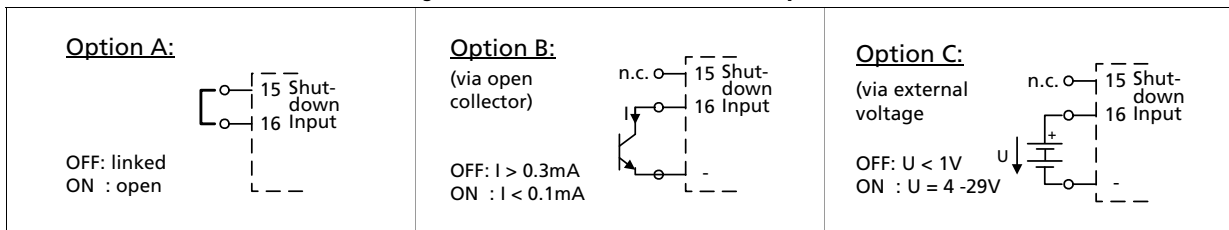
### 9. SHUT-DOWN INPUT

This feature allows a switch-off of the output of the power supply with a signal switch or an external voltage. The shut-down function ramps down and has no safety feature included. The shut-down occurs immediately while the turn-on is delayed up to 350ms. In a shut-down condition, the output voltage is <2V and the output power is <0.5W.

The voltage between different -pole output terminals must be below 1V when units are connected in parallel. In a series operation of multiple power supplies only wiring option "A" with individual signal switches is allowed.

Please note that option C requires a current sink capability of the voltage source. Do not use a blocking diode.

Fig. 9-1 Activation of the shut-down input



### 10. EFFICIENCY AND POWER LOSSES

		<b>3AC 400V</b>	<b>3AC 480V</b>	
Efficiency	typ.	95.4%	95.2%	at 48V, 20A, 3-phase operation
	typ.	94.4%	94.7%	at 48V, 20A, when using only 2 legs of a 3-phase system, curves can be found in chapter 25.7.
Average efficiency *)	typ.	94.7%	94.6%	25% at 5A, 25% at 10A, 25% at 15A. 25% at 20A, 3-phase operation
Power losses	typ.	1.5W	1.5W	with activated shut-down
	typ.	9.5W	9.8W	at 0A, 3-phase operation
	typ.	46.3W	48.4W	at 48V, 20A, 3-phase operation
	typ.	56.9W	53.7W	at 48V, 20A, when using only 2 legs of a 3-phase system, curves can be found in chapter 25.7.

\*) The average efficiency is an assumption for a typical application where the power supply is loaded with 25% of the nominal load for 25% of the time, 50% of the nominal load for another 25% of the time, 75% of the nominal load for another 25% of the time and with 100% of the nominal load for the rest of the time.

Fig. 10-1 Efficiency vs. output current at 48V, typ., 3-phase operation

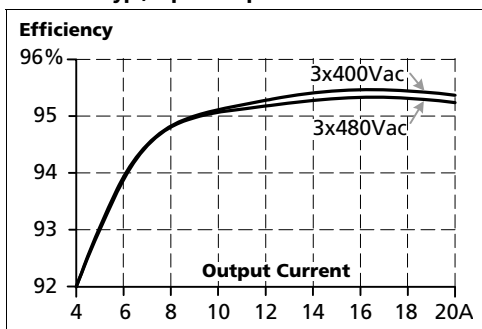


Fig. 10-2 Losses vs. output current at 48V, typ., 3-phase operation

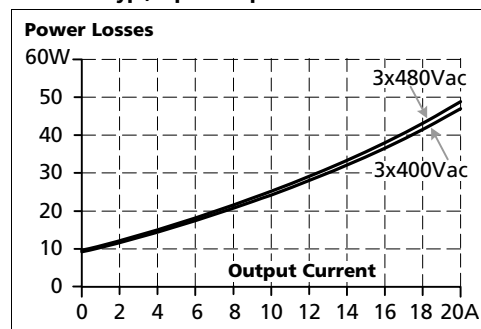


Fig. 10-3 Efficiency vs. input voltage at 48V, 20A, typ., 3-phase operation

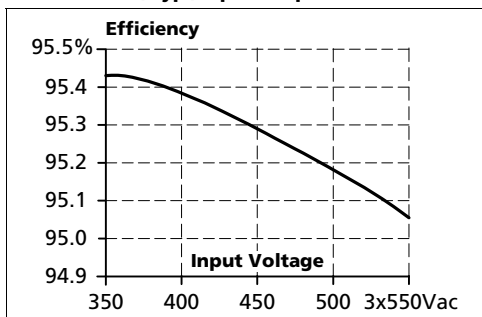
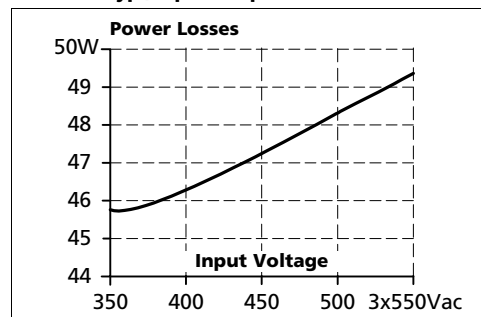


Fig. 10-4 Losses vs. input voltage at 48V, 20A, typ., 3-phase operation



### 11. RELIABILITY

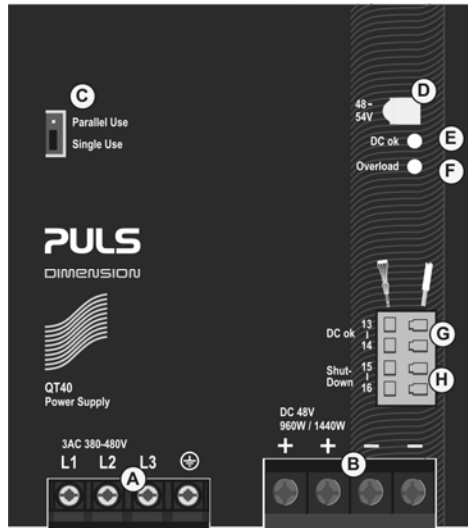
	3AC 400V	3AC 480V	
Lifetime expectancy *)	63 000h	62 000h	at 48V, 20A and 40°C
	111 000h	104 000h	at 48V, 10A and 40°C
	179 000h	174 000h	at 48V, 20A and 25°C
MTBF **) SN 29500, IEC 61709	375 000h	369 000h	at 48V, 20A and 40°C
	685 000h	678 000h	at 48V, 20A and 25°C
MTBF **) MIL HDBK 217F	158 000h	157 000h	at 48V, 20A and 40°C; Ground Benign GB40
	211 000h	210 000h	at 48V, 20A and 25°C; Ground Benign GB25

\*) The **Lifetime expectancy** shown in the table indicates the minimum operating hours (service life) and is determined by the lifetime expectancy of the built-in electrolytic capacitors. Lifetime expectancy is specified in operational hours and is calculated according to the capacitor's manufacturer specification. The prediction model allows only a calculation of up to 15 years from date of shipment.

\*\*) **MTBF** stands for **Mean Time Between Failure**, which is calculated according to statistical device failures, and indicates reliability of a device. It is the statistical representation of the likelihood of a unit to fail and does not necessarily represent the life of a product.

## 12. FRONT SIDE AND USER ELEMENTS

Fig. 12-1 Front side



### A Input Terminals

- Screw terminals
- L1, L2, L3** Line input
- ⊕...PE (Protective Earth) input

### B Output Terminals

- Screw terminals, two per pole
- +** Positive output
- Negative (return) output

### C "Parallel Use" "Single Use" selector

Set jumper to "Parallel Use" when power supplies are connected in parallel to increase the output power. In order to achieve a sharing of the load current between the individual power supplies, the "parallel use" regulates the output voltage in such a manner that the voltage at no load is approx. 5% higher than at nominal load. See also chapter 25.8. A missing jumper is equal to a "Single Use" mode. Factory set is "Single Use" mode.

### D Output voltage potentiometer

Open the flap to set the output voltage. Factory set: 48.0V

### E DC-OK LED (green)

On, when the voltage on the output terminals is >90% of the adjusted output voltage

### F Overload LED (red)

- On, when the voltage on the output terminals is <90% of the adjusted output voltage, or in case of a short circuit in the output. Input voltage is required
- Flashing, when the shut-down has been activated or the unit has switched off due to over-temperature.

### G DC-OK Relay Contact

The DC-OK relay contact is synchronized with the DC-OK LED. See chapter 8 for details.

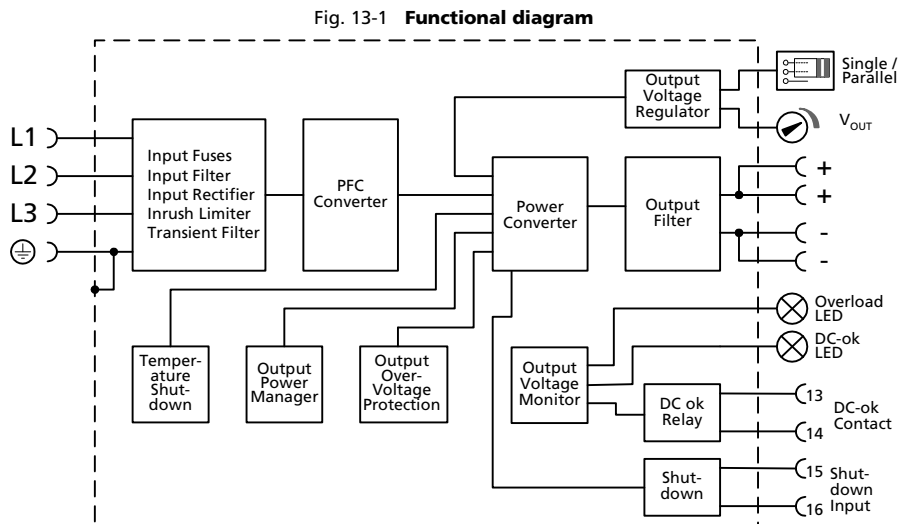
### H Shut-down Input

Allows the power supply to be shut down. Can be activated with a switch contact or an external voltage. See chapter 9 for details.

### Indicators, LEDs

	Overload LED	DC-OK LED	DC-OK Contact
Normal mode	OFF	ON	Closed
During BonusPower®	OFF	ON	Closed
Overload (Vout < 90%)	ON	OFF	Open
Output short circuit	ON	OFF	Open
Temperature Shut-down	flashing	OFF	Open
Active Shut-down input	flashing	OFF	Open
No input power	OFF	OFF	Open

### 13. FUNCTIONAL DIAGRAM



### 14. TERMINALS AND WIRING

	Input	Output	DC-OK, Shut-down
<b>Type</b>	screw termination	screw termination	spring-clamp termination
Solid wire	0.5-6mm <sup>2</sup>	0.5-16mm <sup>2</sup>	0.15-1.5mm <sup>2</sup>
Stranded wire	0.5-4mm <sup>2</sup>	0.5-10mm <sup>2</sup>	0.15-1.5mm <sup>2</sup>
American Wire Gauge	20-10 AWG	22-8 AWG	26-14 AWG
Wire stripping length	7mm / 0.28inch	12mm / 0.5inch	7mm / 0.28inch
Screwdriver	3.5mm slotted or Pozidrive No 2	3.5mm slotted or Pozidrive No 2	3.5mm slotted
Recommended tightening torque	0.8Nm, 7lb.in	0.8Nm, 7lb.in	Not applicable

**Instructions:**

- Use appropriate copper cables that are designed for an operating temperature of: 60°C for ambient up to 45°C and 75°C for ambient up to 60°C minimum.
- Follow national installation codes and installation regulations!
- Ensure that all strands of a stranded wire enter the terminal connection!
- Up to two stranded wires with the same cross section are permitted in one connection point (except PE wire).
- Do not use the unit without PE connection.
- Screws of unused terminal compartments should be securely tightened.
- Ferrules are allowed, but not required

### 15. EMC

The power supply is suitable for applications in industrial environment as well as in residential, commercial and light industry environment without any restrictions. The CE mark indicates conformance with EMC guideline 89/336/EC, 93/68/EC and 2004/108/EC and the low-voltage directive (LVD) 73/23/EC and 2006/95/EC. A detailed EMC report is available on request.

<b>EMC Immunity</b>		According generic standards: EN 61000-6-1 and EN 61000-6-2		
Electrostatic discharge	EN 61000-4-2	Contact discharge	8kV	Criterion A
		Air discharge	15kV	Criterion A
Electromagnetic RF field	EN 61000-4-3	80MHz-2.7GHz	10V/m	Criterion A
Fast transients (Burst)	EN 61000-4-4	Input lines	4kV	Criterion A
		Output lines	2kV	Criterion A
Surge voltage on input	EN 61000-4-5	L1 → L2, L2 → L3, L1 → L3	2kV	Criterion A
Surge voltage on input	EN 61000-4-5	L1 / L2 / L3 → PE	4kV	Criterion A
Surge voltage on output	EN 61000-4-5	+ → -	500V	Criterion A
		+ / - → PE	500V	Criterion A
Conducted disturbance	EN 61000-4-6	0.15-80MHz	10V	Criterion A
Mains voltage dips (Dips on three phases)	EN 61000-4-11	0% of 380Vac	0Vac, 20ms	Criterion A
		0% of 480Vac	0Vac, 20ms	Criterion A
Mains voltage dips (Dips on two phases)	EN 61000-4-11	40% of 380Vac	200ms	Criterion A
		40% of 480Vac	200ms	Criterion A
		70% of 380Vac	500ms	Criterion A
		70% of 480Vac	500ms	Criterion A
Voltage interruptions	EN 61000-4-11		0Vac, 5000ms	Criterion C
Voltage sags	SEMI F47 0706	Dips on two phases according to section 7.2. of the SEMI F47 standard		
		80% of 380Vac	1000ms	Criterion A
		70% of 380Vac	500ms	Criterion A
		50% of 380Vac	200ms	Criterion A
Powerful transients	VDE 0160	Over entire load range	1550V, 1.3ms	Criterion A

**Criteria:**

- A:** Power supply shows normal operation behavior within the defined limits.
- C:** Temporary loss of function is possible. Power supply may shut-down and restarts by itself. No damage or hazards for the power supply will occur.

<b>EMC Emission</b>		According generic standards: EN 61000-6-3 and EN 61000-6-4	
Conducted emission	EN 55011, EN 55022, FCC Part 15, CISPR 11, CISPR 22	Class B, input lines	
Radiated emission	EN 55011, EN 55022	Class B	
Harmonic input current	EN 61000-3-2	fulfilled	
Voltage fluctuations, flicker	EN 61000-3-3	fulfilled	

This device complies with FCC Part 15 rules.

Operation is subjected to following two conditions: (1) this device may not cause harmful interference, and (2) this device must accept any interference received, including interference that may cause undesired operation.

<b>Switching Frequencies</b>		The power supply has three converters with three different switching frequencies included. One is nearly constant. The other two are input voltage and load dependent.	
Switching frequency 1	105kHz	nearly constant	
Switching frequency 2	1kHz to 150kHz	load dependent	
Switching frequency 3	40kHz to 300kHz	input voltage and load dependent	

### 16. ENVIRONMENT

Operational temperature *)	-25°C to +70°C (-13°F to 158°F)	reduce output power according Fig. 16-1
Storage temperature	-40 to +85°C (-40°F to 185°F)	for storage and transportation
Output de-rating	24W/°C	60-70°C (140°F to 158°F)
Humidity **)	5 to 95% r.H.	IEC 60068-2-30
Vibration sinusoidal	2-17.8Hz: ±1.6mm; 17.8-500Hz: 1g 2 hours / axis	IEC 60068-2-6
Shock	15g 6ms, 10g 11ms 3 bumps / direction, 18 bumps in total	IEC 60068-2-27
Altitude	0 to 6000m (0 to 20 000ft)	Reduce output power or ambient temperature above 2000m sea level.
Altitude de-rating	60W/1000m or 5°C/1000m	> 2000m (6500ft), see Fig. 16-2
Over-voltage category	III II	IEC 62103, EN 50178, altitudes up to 2000m Altitudes from 2000m to 6000m
Degree of pollution	2	IEC 62103, EN 50178, not conductive

\*) Operational temperature is the same as the ambient temperature and is defined as the air temperature 2cm below the unit.

\*\*\*) Do not energize while condensation is present

Fig. 16-1 Output current vs. ambient temp.

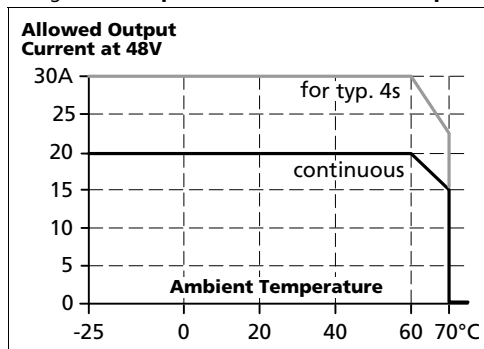
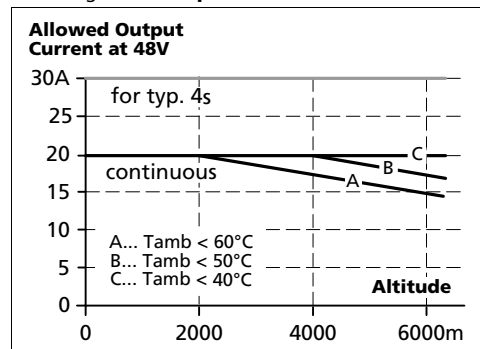


Fig. 16-2 Output current vs. altitude



### 17. PROTECTION FEATURES

Output protection	Electronically protected against overload, no-load and short-circuits *)	
Output over-voltage protection	typ. 58.5Vdc max. 60Vdc	In case of an internal power supply defect, a redundant circuit limits the maximum output voltage. The output shuts down and automatically attempts to restart.
Degree of protection	IP 20	EN/IEC 60529
Penetration protection	> 5mm	e.g. screws, small parts
Over-temperature protection	yes	Output shut-down with automatic restart
Input transient protection	MOV (Metal Oxide Varistor) and active transient filter	
Internal input fuse	3x T6.3A H.B.C.	not user replaceable

\*) In case of a protection event, audible noise may occur.

### 18. SAFETY FEATURES

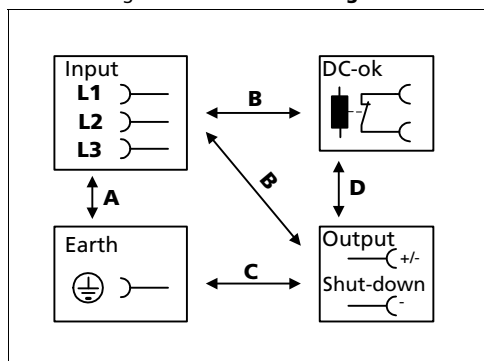
Input / output separation *)	SELV PELV	IEC/EN 60950-1 IEC/EN 60204-1, EN 50178, IEC 62103, IEC 60364-4-41
Class of protection	I	PE (Protective Earth) connection required
Isolation resistance	> 5MΩ	Input to output, 500Vdc
PE resistance	< 0.1Ω	
Touch current (leakage current)	typ. 0.35mA typ. 0.45mA < 0.45mA < 0.60mA	3x 400Vac, 50Hz, TN mains 3x 480Vac, 60Hz, TN mains 3x 440Vac, 50Hz, TN mains 3x 528Vac, 60Hz, TN mains

\*) Double or reinforced insulation

### 19. DIELECTRIC STRENGTH

The output voltage is floating and has no ohmic connection to the ground. Type and factory tests are conducted by the manufacturer. Field tests may be conducted in the field using the appropriate test equipment which applies the voltage with a slow ramp (2s up and 2s down). Connect all phase-terminals together as well as all output poles before conducting the test. When testing, set the cut-off current settings to the value in the table below.

Fig. 19-1 Dielectric strength








		A	B	C	D
Type test	60s	2500Vac	3000Vac	500Vac	500Vac
Factory test	5s	2500Vac	2500Vac	500Vac	500Vac
Field test	5s	2000Vac	2000Vac	500Vac	500Vac
Cut-off current setting		> 10mA	> 10mA	> 80mA	> 10mA

To fulfil the PELV requirements according to EN60204-1 § 6.4.1, we recommend that either the + pole, the - pole or any other part of the output circuit shall be connected to the protective earth system. This helps to avoid situations in which a load starts unexpectedly or can not be switched off when unnoticed earth faults occur.



### 20. APPROVALS

IEC 60950-1 pending		CB Scheme, Information Technology Equipment
UL 508, pending		LISTED for use as Industrial Control Equipment; U.S.A. (UL 508) and Canada (C22.2 No. 107-1-01); E-File: E198865 Mains supply circuit: 3-wire + PE, star
UL 60950-1, pending		Recognized for use as Information Technology Equipment, Level 5; U.S.A. (UL 60950-1) and Canada (C22.2 No. 60950); E-File: E137006
Class I Div 2 pending		Recognized for use in Hazardous Location Class I Div 2 Tx Groups A,B,C,D systems; U.S.A. (ANSI / ISA 12.12.01-2007) and Canada (C22.2 No. 213-M1987); E-File: E246877  The unit is suitable for use in Class I Division 2 Groups A, B, C, D locations. Substitution of components may impair suitability for Class I Division 2 environment. Do not disconnect equipment unless power has been switched off. Wiring must be in accordance with Class I, Division 2 wiring methods of the National Electrical Code, NFPA 70, and in accordance with other local or national codes.
Marine, pending		GL (Germanischer Lloyd) classified and ABS (American Bureau for Shipping) PDA Environmental category: C, EMC2 Marine and offshore applications

### 21. FULFILLED STANDARDS

EN 61558-2-17	Safety of Power Transformers
EN/IEC 60204-1	Safety of Electrical Equipment of Machines
EN/IEC 61131-2	Programmable Controllers
EN 50178, IEC 62103	Electronic Equipment in Power Installations

## 22. USED SUBSTANCES

The unit does not release any silicone and is suitable for use in paint shops.

The unit conforms to the RoHS directive 2002/96/EC

Electrolytic capacitors included in this unit do not use electrolytes such as Quaternary Ammonium Salt Systems.

Plastic housings and other molded plastic materials are free of halogens, wires and cables are not PVC insulated.

The production material within our production does not include following toxic chemicals:

Polychlorized Biphenyl (PCB), Polychlorized Terphenyl (PCT), Pentachlorophenol (PCP), Polychlorinated naphthalene (PCN), Polybrom Biphenyl (PBB), Polybrom Biphenyl-oxyd (PBO), Polybrominated Diphenylether (PBDE), Polychlorinated Diphenylether (PCDE), Polydibromophenyl Oxyd (PBDO), Cadmium, Asbestos, Mercury, Silica

## 23. PHYSICAL DIMENSIONS AND WEIGHT

Weight	1500g / 3.31lb
DIN-Rail	Use 35mm DIN-rails according to EN 60715 or EN 50022 with a height of 7.5 or 15mm. The DIN-rail height must be added to the unit depth (127mm) to calculate the total required installation depth.
Installation Clearances	See chapter 2

Fig. 23-1 Front view

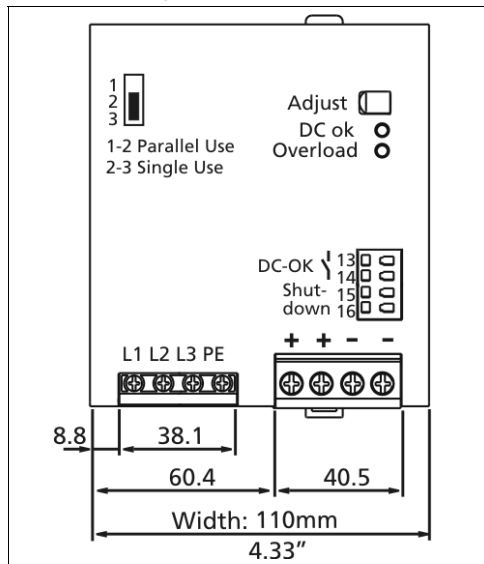
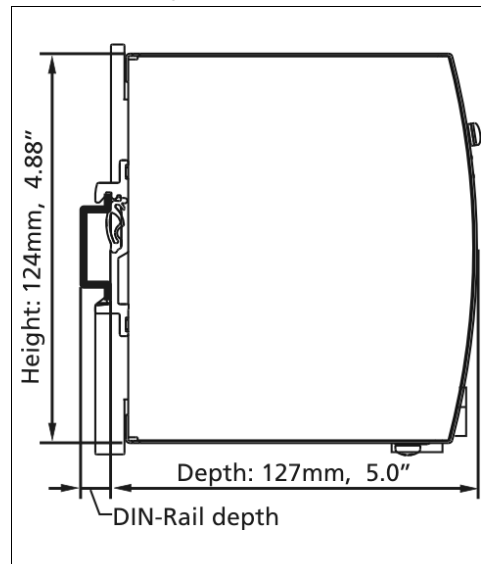


Fig. 23-2 Side view



### 24. ACCESSORIES

#### ZM2.WALL Wall mounting bracket

This bracket is used to mount specific DIMENSION units onto a flat surface without utilizing a DIN-Rail.

Fig. 24-1 ZM2.WALL Wall mounting bracket

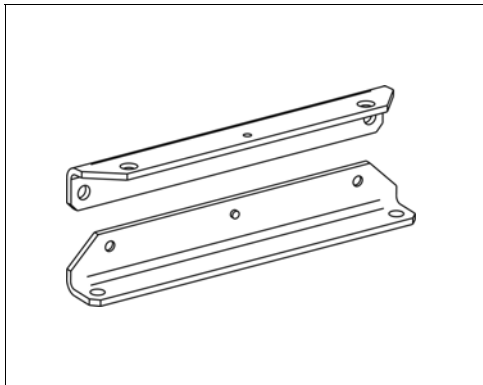
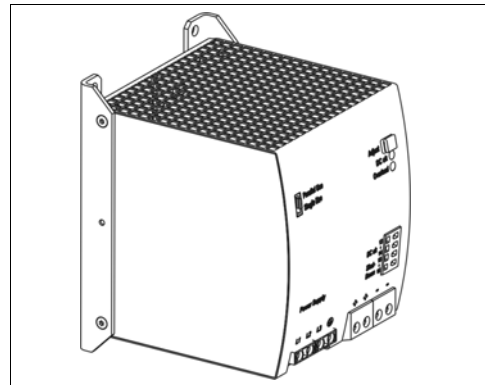
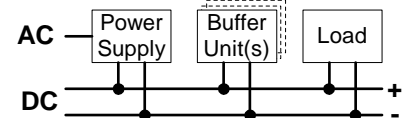


Fig. 24-2 Assembled wall mounting bracket



#### Buffer module UF20.481

This buffer unit is a supplementary device for DC 48V power supplies. It delivers power to bridge typical mains failures or extends the hold-up time after turn-off of the AC power. In times when the power supply provides sufficient voltages, the buffer unit stores energy in integrated electrolytic capacitors. In case of mains voltage fault, this energy is released again in a regulated process. Buffer modules can be connected in parallel to gain longer buffer times.



The buffer unit does not require any control wiring. It can be added in parallel to the load circuit at any given point. Buffer units can be added in parallel to increase the output ampacity or the hold-up time.

## 25. APPLICATION NOTES

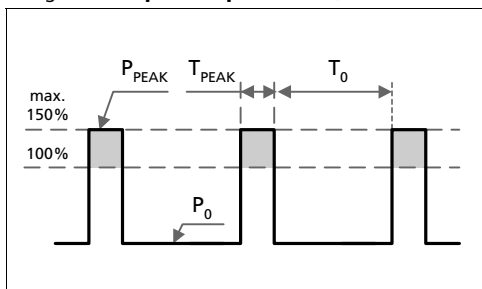
### 25.1. REPETITIVE PULSE LOADING

Typically, a load current is not constant and varies over time. This power supply is designed to support loads with a higher short-term power demand (=BonusPower®). The short-term duration is hardware controlled by an output power manager and is available on a repeated basis. If the BonusPower® load lasts longer than the hardware controller allows it, the output voltage will dip and the next BonusPower® is available after the BonusPower® recovery time (see chapter 6) has elapsed.

To avoid this, the following rules must be met:

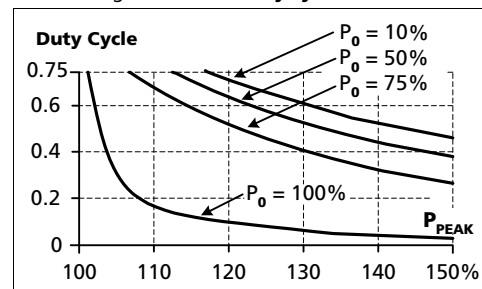
- The power demand of the pulse must be below 150% of the nominal output power.
- The duration of the pulse power must be shorter than the allowed BonusPower® time. (see output section)
- The average (R.M.S.) output current must be below the specified continuous output current.  
If the R.M.S. current is higher, the unit will respond with a thermal shut-down after a period of time. Use the maximum duty cycle curve (Fig. 25-2) to check if the average output current is below the nominal current.
- The duty cycle must be below 0.75.

Fig. 25-1 Repetitive pulse loads, definitions



- P<sub>0</sub> Base load (W)
- P<sub>PEAK</sub> Pulse load (above 100%)
- T<sub>0</sub> Duration between pulses (s)
- T<sub>PEAK</sub> Pulse duration (s)

Fig. 25-2 Max. duty cycle curve



$$\text{DutyCycle} = \frac{T_{\text{peak}}}{T_{\text{peak}} + T_0}$$

$$T_0 = \frac{T_{\text{peak}} - (\text{DutyCycle} \times T_{\text{peak}})}{\text{DutyCycle}}$$

**Example:** A load is powered continuously with 480W (= 50% of the rated output load). From time to time a peak power of 1440W (= 150% of the rated output load) is needed for 1 second.

The question: How often can this pulse be supplied without overloading the power supply?

- Make a vertical line at P<sub>PEAK</sub> = 150% and a horizontal line where the vertical line crosses the P<sub>0</sub> = 50% curve. Read the max. duty cycle from the duty cycle-axis (= 0.37)
- Calculate the required pause (base load) length T<sub>0</sub>:
- Result: The required pause length = 1.7s
- Max. repetition rate = pulse +pause length = **2.7s**

$$T_0 = \frac{T_{\text{peak}} - (\text{DutyCycle} \times T_{\text{peak}})}{\text{DutyCycle}} = \frac{1\text{s} - (0.37 \times 1\text{s})}{0.37} = \mathbf{1.7\text{s}}$$

#### More examples for pulse load compatibility:

P <sub>PEAK</sub>	P <sub>0</sub>	T <sub>PEAK</sub>	T <sub>0</sub>	P <sub>PEAK</sub>	P <sub>0</sub>	T <sub>PEAK</sub>	T <sub>0</sub>
1440W	960W	1s	>25s	1440W	480W	0.1s	>0.16s
1440W	0W	1s	>1.3s	1440W	480W	1s	>1.6s
1200W	480W	1s	> 0.75s	1440W	480W	3s	>4.9s

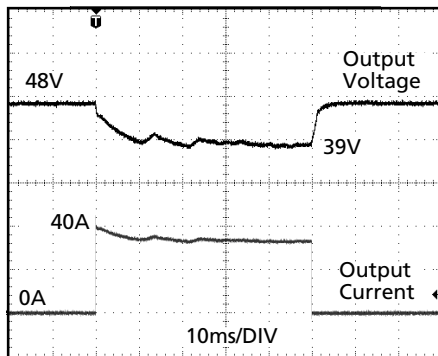
### 25.2. PEAK CURRENT CAPABILITY

Solenoids, contactors and pneumatic modules often have a steady state coil and a pick-up coil. The inrush current demand of the pick-up coil is several times higher than the steady-state current and usually exceeds the nominal output current (including the PowerBoost). The same situation applies when starting a capacitive load.

Branch circuits are often protected with circuit breakers or fuses. In case of a short or an overload in the branch circuit, the fuse needs a certain amount of over-current to trip or to blow. The peak current capability ensures the safe operation of subsequent circuit breakers.

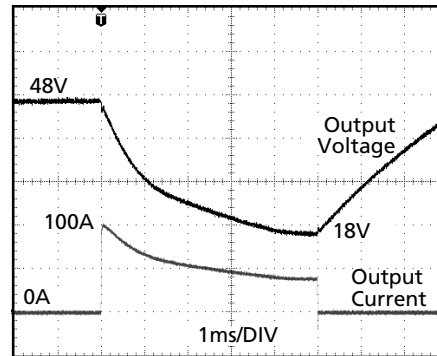
Assuming the input voltage is turned on before such an event, the built-in large sized output capacitors inside the power supply can deliver extra current. Discharging this capacitor causes a voltage dip on the output. The following two examples show typical voltage dips:

Fig. 25-3 Peak load 40A for 50ms, typ.



Peak load 40A (resistive) for 50ms  
Output voltage dips from 48V to 39V.

Fig. 25-4 Peak load 100A for 5ms, typ.



Peak load 100A (resistive) for 5ms  
Output voltage dips from 48V to 18V.

### 25.3. BACK-FEEDING LOADS

Loads such as decelerating motors and inductors can feed voltage back to the power supply. This feature is also called return voltage immunity or resistance against Back- E.M.F. (Electro Magnetic Force).

This power supply is resistant and does not show malfunctioning when a load feeds back voltage to the power supply. It does not matter whether the power supply is on or off.

The maximum allowed feed-back-voltage is 63Vdc. The absorbing energy can be calculated according to the built-in large sized output capacitor which is specified in chapter 6.

### 25.4. EXTERNAL INPUT PROTECTION

The unit is tested and approved for branch circuits up to 30A (U.S.A.) and 32A (IEC). An external protection is only required if the supplying branch has an ampacity greater than this. Check also local codes and local requirements. In some countries local regulations might apply.

If an external fuse is necessary or utilized, minimum requirements need to be considered to avoid nuisance tripping of the circuit breaker. A minimum value of 6A B- or 6A C-Characteristic breaker should be used

### 25.5. CHARGING OF BATTERIES

The power supply can be used to charge lead-acid or maintenance free VRLA batteries. (4 x 12V batteries in series)

**Instructions for charging batteries:**

- a) Set jumper on the front of the unit into "Parallel Use"
- b) Set output voltage (measured at no load and at the battery end of the cable) very precisely to the end-of-charge voltage.

End-of-charge voltage	55.6V	55V	54.3V	53.6V
Battery temperature	10°C	20°C	30°C	40°C

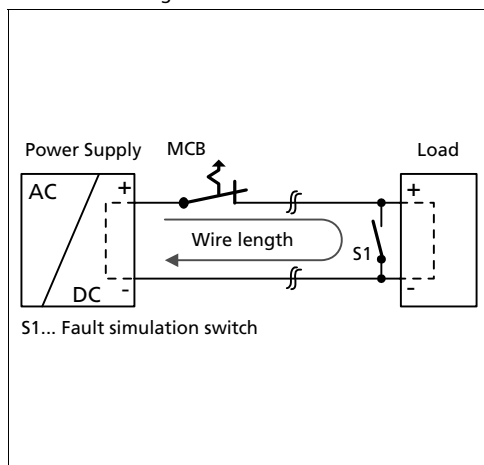
- c) Use a 50A circuit breaker (or blocking diode) between the power supply and the battery.
- d) Ensure that the output current of the power supply is below the allowed charging current of the battery.
- e) Use only matched batteries when putting 12V types in series.
- f) The return current to the power supply (battery discharge current) is typ. 21mA when the power supply is switched off (except in case a blocking diode is utilized).

### 25.6. OUTPUT CIRCUIT BREAKERS

Standard miniature circuit breakers (MCB's or UL1077 circuit breakers) are without doubt, one of the most efficient and economical ways to open circuits on faulty branches. Most of these breakers may also be used on 24V branches. MCB's are designed to protect wires and circuits. If the ampere value and the characteristics of the MCB are adapted to the wire size that is used, the wiring is considered as thermally safe regardless of whether the MCB opens or not.

To avoid voltage dips and under-voltage situations in adjacent 24V branches which are supplied by the same source, a fast (magnetic) tripping of the MCB is desired. A quick shutdown within 10ms is necessary corresponding roughly to the ride-through time of PLC's. This requires power supplies with high current reserves and large output capacitors. Furthermore, the impedance of the faulty branch must be sufficiently small in order for the current to actually flow. The best current reserve in the power supply does not help if Ohm's law does not permit current flow. The following table has typical test results showing which B- and C-Characteristic MCBs magnetically trip depending on the wire cross section and wire length.

Fig. 25-5 Test circuit



Maximal wire length\*) for a magnetic (fast) tripping:

	0.75mm <sup>2</sup>	1.0mm <sup>2</sup>	1.5mm <sup>2</sup>	2.5mm <sup>2</sup>
<b>C-2A</b>	83m	107m	138m	>150m
<b>C-3A</b>	57m	80m	104m	>150m
<b>C-4A</b>	40m	58m	74m	112m
<b>C-6A</b>	15m	18m	28m	44m
<b>C-8A</b>	10m	12m	16m	26m
<b>C-10A</b>	7m	9m	13m	23m
<b>C-13A</b>	3m	4m	6m	9m
<b>B-6A</b>	37m	41m	63m	111m
<b>B-10A</b>	13m	18m	25m	41m
<b>B-13A</b>	5m	12m	23m	34m
<b>B-16A</b>	4m	5m	9m	16m
<b>B-20A</b>	-	-	1m	2m

\*) Don't forget to consider twice the distance to the load (or cable length) when calculating the total wire length (+ and - wire).

### 25.7. USING ONLY 2 LEGS OF A 3-PHASE SYSTEM

The power supply is allowed to run on two legs of a 3-phase system. No external protection devices are required to protect against a phase-loss failure. However, a permanent operation on two legs of a 3-phase system is not recommended for this power class since the supplying 3-phase network can become unbalanced.

The output power must be reduced according to the curves below when operation on only two legs of a 3-phase system. A long-term exceeding of these limits will result in a thermal shut-down of the unit. A use below 340Vac with more than 30A output current can also result in a thermal shut-down.

During power-on, some start-up attempts can occur until a permanent output power is available.

EMC performance, hold-up time, losses and output ripple differ from a three phase operation. Therefore, check suitability of your individual application.

Such use is not included in the UL approval. Additional tests might be necessary when the complete system has to be approved according to UL 508 or UL60950-1.

The screw of the terminal which remains unused must be securely tightened.

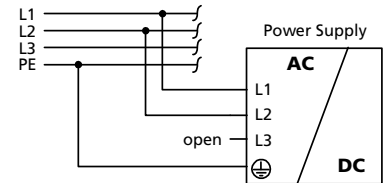


Fig. 25-6

**Output current vs. ambient temperature**

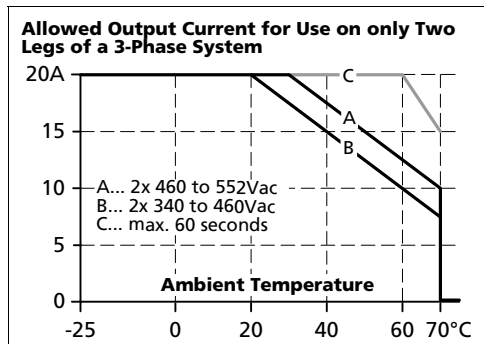


Fig. 25-7

**Hold-up time vs. input voltage**

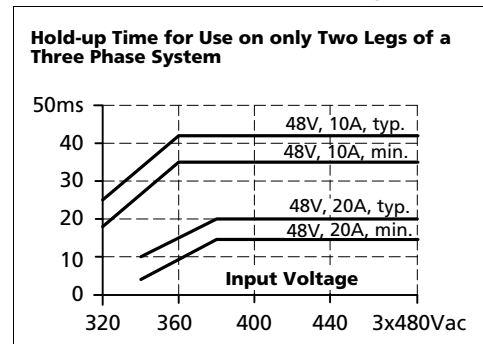


Fig. 25-8

**Efficiency vs. output current at 48V**

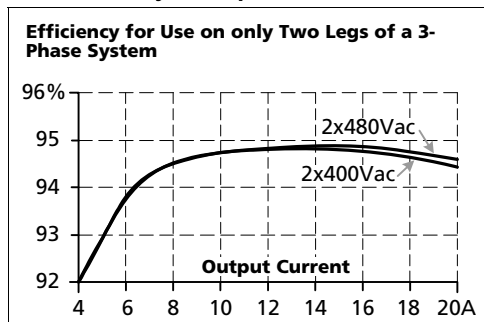
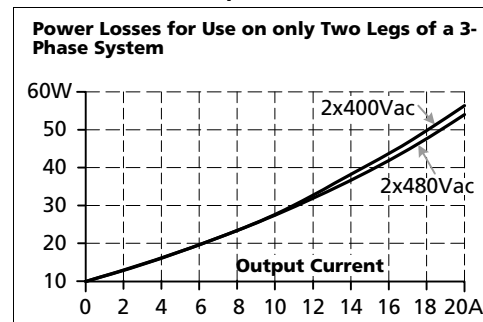


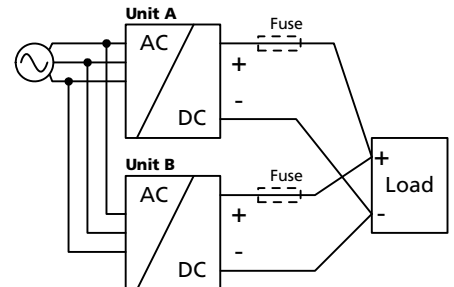
Fig. 25-9

**Losses vs. output current at 48V**



### 25.8. PARALLEL USE TO INCREASE OUTPUT POWER

Power supplies from the same series (Q-Series) can be paralleled to increase the output power. The output voltage shall be adjusted to the same value ( $\pm 100\text{mV}$ ) in "Single use" mode at with the same load conditions on all units, or the units can be left with the factory settings. After the adjustments, the jumper on the front of the unit shall be moved from "Single use" to "Parallel use" mode in order to achieve load sharing. The "Parallel use" mode regulates the output voltage in such a manner that the voltage at no load is approx. 5% higher than at nominal load. If no jumper is plugged in, the unit is in "Single use" mode. Factory setting is also "Single use" mode. A fuse (or diode) on the output of each unit is only required if more than three units are connected in parallel. Keep an installation clearance of 15mm (left / right) between two power supplies and avoid installing the power supplies on top of each other. Do not use power supplies in parallel in mounting orientations other than the standard mounting orientation (input and output terminals on the bottom of the unit) or in any other condition where a derating of the output current is required (e.g. altitude, above 60°C, ...). Pay attention that leakage current, EMI, inrush current, harmonics will increase when using multiple power supplies.



### 25.9. PARALLEL USE FOR REDUNDANCY

Power supplies can be paralleled for redundancy to gain higher system availability. Redundant systems require a certain amount of extra power to support the load in case one power supply unit fails. The simplest way is to put two power supplies in parallel. This is called a 1+1 redundancy. In case one power supply unit fails, the other one is automatically able to support the load current without any interruption. Redundant systems for a higher power demand are usually built in a N+1 method. E.g. five power supplies, each rated for 20A are paralleled to build a 80A redundant system. For N+1 redundancy the same restrictions apply as for increasing the output power, see also section 25.8.

**Please note:** This simple way to build a redundant system does not cover failures such as an internal short circuit in the secondary side of the power supply. In such a case, the defective unit becomes a load for the other power supplies and the output voltage can not be maintained any more. This can be avoided by utilizing decoupling diodes which are included in the redundancy module YR2.DIODE (one for each power supply).

Recommendations for building redundant power systems:

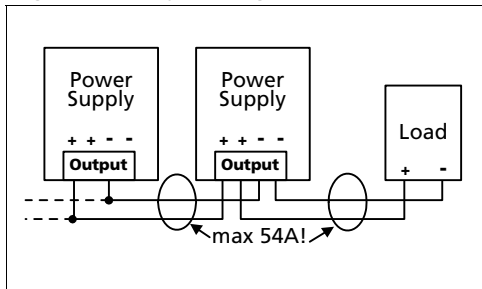
- Use separate input fuses for each power supply.
- Set the power supply into "Parallel Use" mode.
- Monitor the individual power supply units. Therefore, use the DC-OK relay contact of the QT40 power supply.
- It is desirable to set the output voltages of all units to the same value ( $\pm 100\text{mV}$ ) or leave it at the factory setting.



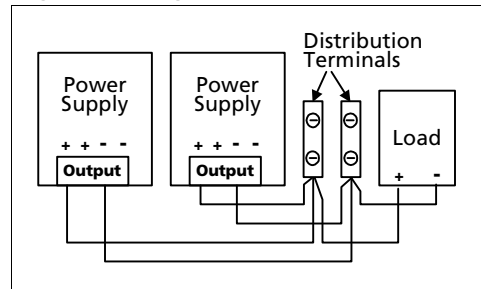
### 25.10. DAISY CHAINING OF OUTPUTS

Daisy chaining (jumping from one power supply output to the next) is allowed as long as the average output current through one terminal pin does not exceed 54A. If the current is higher, use a separate distribution terminal block.

**Fig. 25-10 Daisy chaining of outputs**

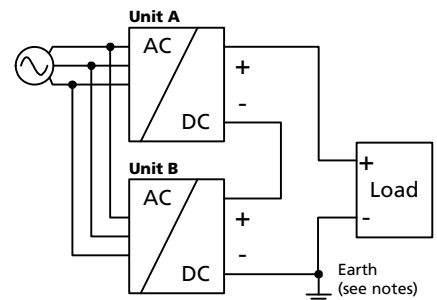


**Fig. 25-11 Using distribution terminals**



### 25.11. SERIES OPERATION

Power supplies of the same type can be connected in series for higher output voltages. It is possible to connect as many units in series as needed, providing the sum of the output voltage does not exceed 150Vdc. Voltages with a potential above 60Vdc are not SELV any more and can be dangerous. Such voltages must be installed with a protection against touching. Earthing of the output is required when the sum of the output voltage is above 60Vdc. Avoid return voltage (e.g. from a decelerating motor or battery) which is applied to the output terminals. Keep an installation clearance of 15mm (left / right) between two power supplies and avoid installing the power supplies on top of each other.. Pay attention that leakage current, EMI, inrush current, harmonics will increase when using multiple power supplies.



### 25.12. INDUCTIVE AND CAPACITIVE LOADS

The unit is designed to supply any kind of loads, including unlimited capacitive and inductive loads.

### 25.13. USE IN A TIGHTLY SEALED ENCLOSURE

When the power supply is installed in a tightly sealed enclosure, the temperature inside the enclosure will be higher than outside. In such situations, the inside temperature defines the ambient temperature for the power supply.

The following measurement results can be used as a reference to estimate the temperature rise inside the enclosure.

The power supply is placed in the middle of the box, no other heat producing items are inside the box

Enclosure:	Rittal Typ IP66 Box PK 9522 100, plastic, 250x180x165mm
Load:	48V, 16A; (=80%) load is placed outside the box
Input:	3x 400Vac
Temperature inside enclosure:	51.0°C (in the middle of the right side of the power supply with a distance of 2cm)
Temperature outside enclosure:	21.8°C
Temperature rise:	29.2K

### 25.14. MOUNTING ORIENTATIONS

Mounting orientations other than input terminals on the bottom and output on the top require a reduction in continuous output power or a limitation in the max. allowed ambient temperature. The amount of reduction influences the lifetime expectancy of the power supply. Therefore, two different derating curves for continuous operation can be found below:

**Curve A1** Recommended output current.

**Curve A2** Max allowed output current (results in approximately half the lifetime expectancy of A1).

Fig. 25-12  
**Mounting Orientation A**  
(Standard orientation)

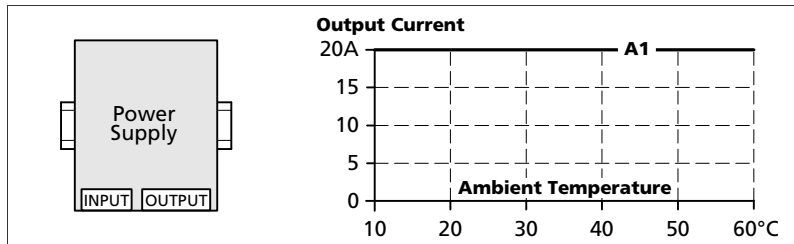


Fig. 25-13  
**Mounting Orientation B**  
(Upside down)

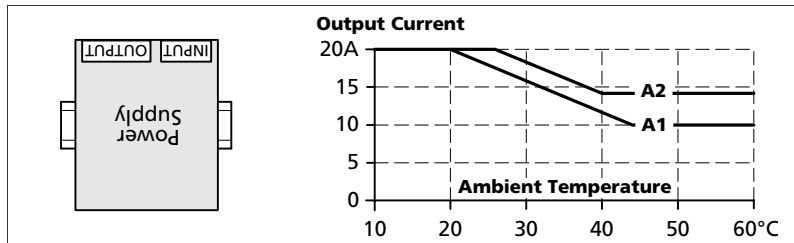


Fig. 25-14  
**Mounting Orientation C**  
(Table-top mounting)

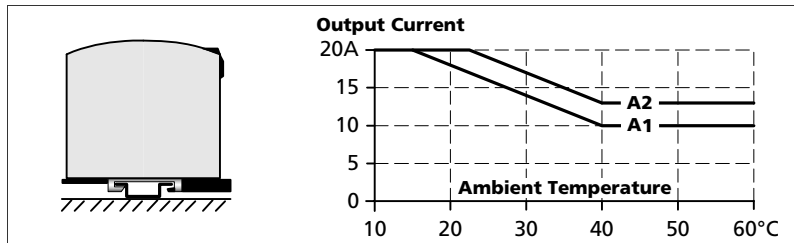


Fig. 25-15  
**Mounting Orientation D**  
(Horizontal cw)

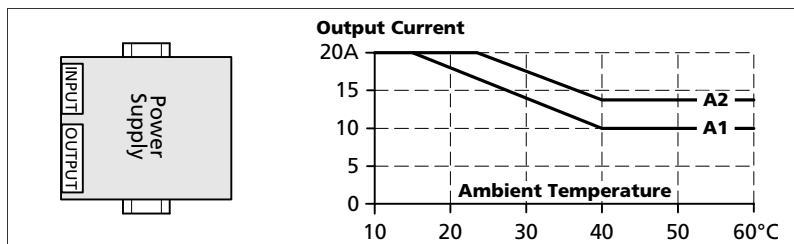


Fig. 25-16  
**Mounting Orientation E**  
(Horizontal ccw)

